

TRANSMISSION SERVICE AGREEMENT

FOR

**DEVELOPMENT AND OPERATION OF INTER-STATE
TRANSMISSION SYSTEM**

**FOR TRANSMISSION OF ELECTRICITY THROUGH TARIFF
BASED COMPETITIVE BIDDING FOR**

**TRANSMISSION SYSTEM FOR EVACUATION OF POWER
FROM POTENTIAL RENEWABLE ENERGY ZONE IN
KHAVDA AREA OF GUJARAT UNDER PHASE-V (8GW):
PART C**

BETWEEN THE

**CENTRAL TRANSMISSION UTILITY OF INDIA LIMITED
(NODAL AGENCY)**

AND

KPS III HVDC TRANSMISSION LIMITED

Transmission Service Agreement

CONTENTS

1. Definitions and Interpretations	5
2. Effectiveness and Term of Agreement	18
3. Conditions Subsequent	21
4. Development of the Project.....	26
5. Construction of the Project.....	31
6. Connection and commissioning of the Project.....	36
7. Operation and Maintenance of the Project.....	41
8. Availability of the project.....	42
9. Insurances	43
10. Billing And Payment of Transmission Charges.....	45
11. Force Majeure	46
12. Change in Law	51
13. Events of Default and Termination	54
14. Liability and Indemnification.....	60
15. Assignments and Charges	66
16. Governing Law and Dispute Resolution.....	68
17. Representation and Warranties.....	70
18. Independent Engineer	72
19. Miscellaneous Provisions	74

THIS TRANSMISISON SERVICE AGREEMENT (hereinafter referred to as “TSA” or “Agreement” or “the Agreement” or “this Agreement”) is made on the [Insert day] of..... [Insert month] of Two Thousand and..... [Insert Year]

BETWEEN:

The[Insert name and registered address of Nodal Agency for the project], acting as a Nodal Agency (referred to as the “Nodal Agency”), which expression shall unless repugnant to the context or meaning thereof include its successors, and permitted assigns) as Party of the one part;

AND

..... [Insert Name of the Transmission Service Provider], incorporated under the Companies Act, 1956/ Companies Act, 2013 (as the case may be), having its registered office at (herein after referred to as “Transmission Service Provider” or “TSP” or “ISTS Licensee”, which expression shall unless repugnant to the context or meaning thereof include its successors, and permitted assigns) as Party of the other part;

(“Nodal Agency” and “TSP” are individually referred to as “Party” and collectively as the “Parties”)

AND WHEREAS:

- A) In accordance with the Bidding Guidelines, the Bid Process Coordinator (hereinafter referred to as BPC) had initiated a competitive e-reverse bidding process through issue of RFP for selecting a Successful Bidder to build, own, operate and transfer the Project comprising of the Elements mentioned in Schedule 1 (hereinafter referred to as the Project)
- B) Pursuant to the said e-reverse bidding process, the BPC has identified the Successful Bidder, who will be responsible to set up the Project on build, own, operate and transfer basis to provide Transmission Service in accordance with the terms of this Agreement and the Transmission License.
- C) The Selected Bidder have submitted the Contract Performance Guarantee and acquired one hundred percent (100%) of the equity shareholding of [Insert Name of the SPV], along with all its related assets and liabilities in terms of the provisions of the Share Purchase Agreement.
- D) The TSP has agreed to make an application for a Transmission License to the Commission for setting up the Project on build, own, operate and transfer basis.
- E) The TSP has further agreed to make an application to the Commission for the adoption of the Transmission Charges under Section 63 of the Electricity Act, 2003, along with a certification from the Bid Evaluation Committee in accordance with the Bidding Guidelines issued by Ministry of Power, Government of India.

Transmission Service Agreement

- F) The TSP has agreed to execute the agreement(s) required, if any, under Sharing Regulations within fifteen (15) days from the date of grant of Transmission License from the Commission.
- G) The TSP agrees to the terms and conditions laid down under Sharing Regulations, for making available the ISTS and charge the Transmission Charges in accordance with the terms and conditions of Sharing Regulations.
- H) The billing, collection and disbursement of the Transmission Charges by the CTU to the ISTS Licensee shall be governed as per Sharing Regulations.
- I) The terms and conditions stipulated in the Transmission License issued by the Commission to the TSP shall be applicable to this Agreement and the TSP agrees to comply with these terms and conditions. In case of inconsistency between the Transmission License terms & conditions and the conditions of this Agreement, the conditions stipulated in the Transmission License granted by the Commission shall prevail.

NOW, THEREFORE, IN CONSIDERATION OF THE PREMISES AND MUTUAL AGREEMENTS, COVENANTS AND CONDITIONS SET FORTH HEREIN, IT IS HEREBY AGREED BY AND BETWEEN THE PARTIES HERETO AS FOLLOWS:

ARTICLE: 1

1 DEFINITIONS AND INTERPRETATIONS

1.1 Definitions:

1.1.1 The words / expressions used in this Agreement, unless as defined below or repugnant to the context, shall have the same meaning as assigned to them by the Electricity Act, 2003 and the rules or regulations framed there under including those issued / framed by the Commission (as defined hereunder), as amended or re-enacted from time to time or the General Clauses Act, failing which it shall bear its ordinary English meaning.

The words/expressions when used in this Agreement shall have the respective meanings as specified below:

“Acquisition Price” shall have the same meaning as defined in the Share Purchase Agreement;

“Act” or **“Electricity Act”** or **“Electricity Act 2003”** shall mean the Electricity Act, 2003 and any amendments made to the same or any succeeding enactment thereof;

“Affiliate” shall mean a company that either directly or indirectly

- (i) controls or
- (ii) is controlled by or
- (iii) is under common control with

a Bidding Company (in the case of a single company) or a Member (in the case of a Consortium) and **“control”** means ownership by one entity of at least twenty six percent (26%) of the voting rights of the other entity;

“Availability” in relation to the Project or in relation to any Element of the Project, for a given period shall mean the time in hours during that period the Project is capable to transmit electricity at its Rated Voltage and shall be expressed in percentage of total hours in the given period and shall be calculated as per the procedure contained in Appendix –IV to Central Electricity Regulatory Commission (Terms and Conditions of Tariff) Regulations, 2024, attached herewith in Schedule 6;

“Bid” shall mean technical bid and financial bid submitted by the Bidder, in response to the RFP, in accordance with the terms and conditions of the RFP;

“Bid Deadline” shall mean the last date and time for submission of the Bid in response to RFP, as specified in the RFP;

“Bidding Company” shall refer to such single company that has made a Response to RFP for the Project;

Transmission Service Agreement

“Bidding Consortium / Consortium” shall refer to a group of companies that has collectively made a Response to RFP for the Project;

“Bid Documents” or **“Bidding Documents”** shall mean the RFP, along with all attachments thereto or clarifications thereof;

“Bidding Guidelines” shall mean the “Tariff Based Competitive Bidding Guidelines for Transmission Service” and “Guidelines for Encouraging Competition in Development of Transmission Projects” issued by Government of India, Ministry of Power under Section – 63 of the Electricity Act as amended from time to time;

“Bid Process Coordinator” or **“BPC”** shall mean a person or its authorized representative as notified by the Government of India, responsible for carrying out the process for selection of Bidder who will acquire Transmission Service Provider;

“Bill” shall mean any bill raised by the CTU on the DICs to recover the Transmission Charges pursuant to the Sharing Regulations;

“Business Day” shall mean a day other than Sunday or a statutory holiday, on which the banks remain open for business in the State in which the Nodal Agency’s registered office is located and the concerned TSP are located;

“CEA” shall mean the Central Electricity Authority constituted under Section -70 of the Electricity Act;

“Change in law” shall have the meaning ascribed thereto in Article 12;

“Commercial Operation Date” or **“COD”** shall mean the date as per Article 6.2;

“Commission” or **“CERC”** shall mean the Central Electricity Regulatory Commission referred to in sub-section (1) of Section 76 of the Electricity Act, 2003 or its successors and assigns;

“Competent Court of Law” shall mean the Supreme Court or any High Court, or any tribunal or any similar judicial or quasi-judicial body in India that has jurisdiction to adjudicate upon issues relating to the Project;

“Connection Agreement” shall mean the agreement between the CTU or STU or any other concerned parties and the TSP, setting out the terms relating to the connection of the Project to the Inter-connection Facilities and use of the Inter State Transmission System as per the provisions of the IEGC, as the case may be;

“Consultation Period” shall mean the period of sixty (60) days or such longer period as the Parties may agree, commencing from the date of issue of a TSP’s Preliminary Notice or a Nodal Agency’s Preliminary Termination Notice, as provided in Article 13

Transmission Service Agreement

of this Agreement, for consultation between the Parties to mitigate the consequence of the relevant event having regard to all the circumstances;

“Consents, Clearances and Permits” shall mean all authorizations, licenses, approvals, registrations, permits, waivers, privileges, acknowledgements, agreements, or concessions required to be obtained from or provided by any concerned authority for the development, execution and operation of Project including without any limitation for the construction, ownership, operation and maintenance of the Transmission Lines and/or sub-stations;

“Construction Period” shall mean the period from (and including) the Effective Date of the Transmission Service Agreement up to (but not including) the COD of the Element of the Project in relation to an Element and up to (but not including) the COD of the Project in relation to the Project;

“Contractors” shall mean the engineering, procurement, construction, operation & maintenance contractors, surveyors, advisors, consultants, designers, suppliers to the TSP and each of their respective sub-contractors (and each of their respective successors and permitted assigns) in their respective capacities as such;

“Contract Performance Guarantee” shall mean the irrevocable unconditional bank guarantee, submitted and to be submitted by the TSP or by the Selected Bidder on behalf of the TSP to the Nodal Agency from a bank mentioned in Annexure 17 of the RFP, in the form attached here to as Schedule 8, in accordance with Article 3 of this Agreement and which shall include the additional bank guarantee furnished by the TSP under this Agreement;

“Contract Year”, for the purpose of payment of Transmission Charges, shall mean the period beginning on the COD, and ending on the immediately succeeding March 31 and thereafter each period of 12 months beginning on April 1 and ending on March 31 provided that the last Contract Year shall end on the last day of the term of the TSA;

“CTU” or “Central Transmission Utility” shall have same meaning as defined in the Electricity Act, 2003;

“Day” shall mean a day starting at 0000 hours and ending at 2400 hours;

“D/C” shall mean Double Circuit;

“Designated ISTS Customers” or “DICs” shall have the meaning as ascribed in the Sharing Regulations;

“Dispute” shall mean any dispute or difference of any kind between the Parties, in connection with or arising out of this Agreement including any issue on the interpretation and scope of the terms of this Agreement as provided in Article 16;

Transmission Service Agreement

“Effective Date” for the purposes of this Agreement, shall have the same meaning as per Article 2.1 of this Agreement;

“Electrical Inspector” shall mean a person appointed as such by the Government under sub-section (1) of Section 162 of the Electricity Act 2003 and also includes Chief Electrical Inspector;

“Electricity Rules 2005” shall mean the rules framed pursuant to the Electricity Act 2003 and as amended from time to time;

“Element” shall mean each Transmission Line or each circuit of the Transmission Lines (where there are more than one circuit) or each bay of Sub-station or switching station or HVDC terminal or inverter station of the Project, including ICTs, Reactors, SVC, FSC, etc. forming part of the ISTS, which will be owned, operated and maintained by the concerned ISTS Licensee, and which has a separate Scheduled COD as per Schedule 2 of this Agreement and has a separate percentage for recovery of Transmission Charges on achieving COD as per Schedule 5 of this Agreement;

“Event of Default” shall mean the events as defined in Article 13 of this Agreement;

“Expiry Date” shall be the date which is thirty five (35) years from the COD of the Project;

“Financial Closure” shall mean the first Business Day on which funds are made available to the TSP pursuant to the Financing Agreements;

“Financially Evaluated Entity” shall mean the company which has been evaluated for the satisfaction of the financial requirement set forth in the RFP;

“Financing Agreements” shall mean the agreements pursuant to which the TSP is to finance the Project including the loan agreements, security documents, notes, indentures, security agreements, letters of credit and other documents, as may be amended, modified, or replaced from time to time, but without in anyway increasing the liabilities of the Designated ISTS Customers / Nodal Agency;

“Financial Year” shall mean a period of twelve months at midnight Indian Standard Time (IST) between 1st April & 31st March;

“Force Majeure” and **“Force Majeure Event”** shall have the meaning assigned thereto in Article 11;

“GOI” shall mean Government of India;

“Grid Code” / “IEGC” shall mean the Grid Code specified by the Central Commission under Clause (h) of sub-section (1) of Section 79 of the Electricity Act;

Transmission Service Agreement

“Independent Engineer” shall mean an agency/ company, appointed by Nodal Agency in accordance with the Guidelines for Encouraging Competition in Development of Transmission Projects.

“Indian Governmental Instrumentality” shall mean Government of India, Government of any State in India or any ministry, department, board, authority, agency, corporation, commission under the direct or indirect control of Government of India or any State Government or both, any political sub-division of any of them including any court or Commission or tribunal or judicial or quasi-judicial body in India but excluding the CTU, TSP and the Designated ISTS Customers;

“Insurances” shall mean the insurance cover to be obtained and maintained by the TSP in accordance with Article 9 of this Agreement;

“Interconnection Facilities” shall mean the facilities as may be set up for transmission of electricity through the use of the Project, on either one or both side of generating station’s / CTU’s / STU’s / ISTS Licensee’s / Designated ISTS Customer’s substations (as the case may be) which shall include, without limitation, all other transmission lines, gantries, sub-stations and associated equipments not forming part of the Project;

“ISTS Licensee” shall be the TSP under this Agreement, consequent to having been awarded a Transmission License by the CERC and shall be referred to as the TSP or the ISTS Licensee, as the context may require in this Agreement;

“Law” or “Laws” in relation to this Agreement, shall mean all laws including electricity laws in force in India and any statute, ordinance, rule, regulation, notification, order or code, or any interpretation of any of them by an Indian Governmental Instrumentality having force of law and shall include all rules, regulations, decisions and orders of the Commission;

“Lead Member of the Bidding Consortium” or “Lead Member” shall mean a company who commits at least 26% equity stake in the Project, meets the technical requirement as specified in the RFP and so designated by other Member(s) in Bidding Consortium;

“Lenders” means the banks, financial institutions, multilateral funding agencies, non banking financial companies registered with the Reserve Bank of India (RBI), insurance companies registered with the Insurance Regulatory & Development Authority (IRDA), pension funds regulated by the Pension Fund Regulatory & Development Authority (PFRDA), mutual funds registered with Securities & Exchange Board of India (SEBI), etc., including their successors and assigns, who have agreed on or before COD of the Project to provide the TSP with the debt financing described in the capital structure schedule, and any successor banks or financial institutions to whom their interests under the Financing Agreements may be transferred or assigned;

Transmission Service Agreement

Provided that, such assignment or transfer shall not relieve the TSP of its obligations to the Nodal Agency under this Agreement in any manner and shall also does not lead to an increase in the liability of the Nodal Agency;

“Lenders Representative” shall mean the person notified by the Lender(s) in writing as being the representative of the Lender(s) or the Security Trustee and such person may from time to time be replaced by the Lender(s) pursuant to the Financing Agreements by written notice to the TSP;

“Letter of Intent” or **“LOI”** shall have the same meaning as in the RFP;

“Member in a Bidding Consortium / Member” shall mean each company in the Bidding Consortium;

“Month” shall mean a period of thirty (30) days from (and excluding) the date of the event;

“Monthly Transmission Charges” for any Element of the Project, after COD of the Element till COD of the Project, and for the Project after COD of the Project, shall mean the amount of Transmission Charges as specified in Schedule 5 of this Agreement multiplied by no. of days in the relevant month and divided by no. of days in the year;

“National Load Despatch Centre” shall mean the centre established as per sub-section (1) of Section 26 of the Electricity Act 2003;

“Nodal Agency” shall mean CTU, which shall execute and implement the Transmission Service Agreement (TSA);

Provided that while taking major decisions, CTU shall consult CEA on technical matters and any other matter it feels necessary.

“Notification” shall mean any notification, issued in the Gazette of India;

“Operating Period” for any Element of the Project shall mean the period from (and including) the COD of such Element of the Project, up to (and including) the Expiry Date and for the Project, shall mean the period from (and including) the COD of the Project, up to (and including) the Expiry Date;

“Parent Company” shall mean an entity that holds at least twenty six percent (26%) of the paid - up equity capital directly or indirectly in the Bidding Company or in the Member in a Bidding Consortium, as the case may be;

“Preliminary Termination Notice” shall mean a Nodal Agency’s Preliminary Termination Notice as defined in Article 13 of this Agreement;

Transmission Service Agreement

“Project” shall mean “Transmission System for Evacuation of Power from potential renewable energy zone in Khavda area of Gujarat under Phase-V (8GW): Part C”, as detailed in Schedule 1 of this Agreement;

“Project Assets” shall mean all physical and other assets relating to and forming part of the Project including:

- (a) rights over the Site for substations, ROW for transmission lines;
- (b) tangible & intangible assets such as civil works and equipment including foundations, embankments, pavements, electrical systems, communication systems, relief centres, administrative offices, Sub-stations, software, tower and sub-stations designs etc;
- (c) project facilities situated on the Site;
- (d) all rights of the TSP under the project agreements;
- (e) financial assets, such as receivables, security deposits etc;
- (f) insurance proceeds; and
- (g) Applicable Permits and authorisations relating to or in respect of the Transmission System;”

“Project Execution Plan” shall mean the plan referred to in Article 3.1.3(c) hereof;

“Prudent Utility Practices” shall mean the practices, methods and standards that are generally accepted internationally from time to time by electric transmission utilities for the purpose of ensuring the safe, efficient and economic design, construction, commissioning, operation, repair and maintenance of the Project and which practices, methods and standards shall be adjusted as necessary, to take account of:

- (i) operation, repair and maintenance guidelines given by the manufacturers to be incorporated in the Project,
- (ii) the requirements of Law, and
- (iii) the physical conditions at the Site;
- (iv) the safety of operating personnel and human beings;

“Rated Voltage” shall mean voltage at which the Transmission System is designed to operate or such lower voltage at which the line is charged, for the time being, in consultation with the Central Transmission Utility;

“Rebate” shall have the meaning as ascribed to in Article 10.3 of this Agreement;

Transmission Service Agreement

“RFP” shall mean Request For Proposal dated 26.07.2024 along with all schedules, annexures and RFP Project Documents attached thereto, issued by the BPC for tariff based competitive bidding process for selection of Bidder as TSP to execute the Project, including any modifications, amendments or alterations thereto;

“RFP Project Documents” shall mean the following documents to be entered into in respect of the Project, by the Parties to the respective agreements:

- a. Transmission Service Agreement,
- b. Share Purchase Agreement,
- c. Agreement(s) required under Sharing Regulations and
- d. Any other agreement as may be required;

“RLDC” shall mean the relevant Regional Load Dispatch Centre as defined in the Electricity Act, 2003, in the region(s) in which the Project is located;

“RPC” shall mean the relevant Regional Power Committee established by the Government of India for the specific Region(s) in accordance with the Electricity Act, 2003 for facilitating integrated operation of the Power System in that Region;

“Scheduled COD” in relation to an Element(s) shall mean the date(s) as mentioned in Schedule 2 as against such Element(s) and in relation to the Project, shall mean the date as mentioned in Schedule 2 as against such Project, subject to the provisions of Article 4.4 of this Agreement, or such date as may be mutually agreed among the Parties;

“Scheduled Outage” shall mean the final outage plan as approved by the RPC as per the provisions of the Grid Code;

“Selected Bid” shall mean the technical Bid and the Final Offer of the Selected Bidder submitted during e-reverse bidding, which shall be downloaded and attached in Schedule 7 on or prior to the Effective Date;

“Share Purchase Agreement” shall mean the agreement amongst **PFC Consulting Limited (PFCL)**, KPS III HVDC TRANSMISSION LIMITED and the Successful Bidder for the purchase of one hundred (100%) per cent of the shareholding of the KPS III HVDC TRANSMISSION LIMITED for the Acquisition Price, by the Successful Bidder on the terms and conditions as contained therein;

“Sharing Regulations” shall mean the Central Electricity Regulatory Commission (Sharing of Inter-State Transmission Charges and Losses) Regulations, 2020 and as amended from time to time;

Transmission Service Agreement

“Site” in relation to a substation, switching station or HVDC terminal or inverter station, shall mean the land and other places upon which such station / terminal is to be established;

“SLDC” shall mean the State Load Despatch Centre established as per sub-section (1) of Section 31 of the Electricity Act 2003;

“STU” or **“State Transmission Utility”** shall be the Board or the Government company, specified as such by the State Government under sub-section (1) of Section 39 of the Electricity Act 2003;

“Successful Bidder” or **“Selected Bidder”** shall mean the Bidder selected pursuant to the RFP and who has to acquire one hundred percent (100%) equity shares of KPS III HVDC TRANSMISSION LIMITED, along with all its related assets and liabilities, which will be responsible as the TSP to establish the Project on build, own, operate and transfer basis as per the terms of the TSA and other RFP Project Documents;

“TSP’s Preliminary Notice” shall mean a notice issued by the TSP in pursuant to the provisions of Article 13.3 of this Agreement;

“Target Availability” shall have the meaning as ascribed hereto in Article 0 of this Agreement;

“Technically Evaluated Entity” shall mean the company which has been evaluated for the satisfaction of the technical requirement set forth in RFP;

“Termination Notice” shall mean a Nodal Agency’s Termination Notice given by the Nodal Agency to the TSP pursuant to the provisions of Articles 3.3.1, 3.3.4, 4.4.2, 5.8, 13.2 and 13.3 of this Agreement for the termination of this Agreement;

“Term of Agreement” for the purposes of this Agreement shall have the meaning ascribed thereto in Article 2.2 of this Agreement;

“Transmission Charges” shall mean the Final Offer of the Selected Bidder during the e-reverse bidding and adopted by the Commission, payable to the TSP as per Sharing Regulations;

“Transmission License” shall mean the license granted by the Commission in terms of the relevant regulations for grant of such license issued under the Electricity Act;

“Transmission Service” shall mean making the Project available as per the terms and conditions of this Agreement and Sharing Regulations;

“Unscheduled Outage” shall mean an interruption resulting in reduction of the Availability of the Element(s) / Project (as the case may be) that is not a result of a Scheduled Outage or a Force Majeure Event.

"Ultimate Parent Company" shall mean an entity which owns at least twenty six percent (26%) equity in the Bidding Company or Member of a Consortium, (as the case may be) and in the Technically Evaluated Entity and / or Financially Evaluated Entity (as the case may be) and such Bidding Company or Member of a Consortium, (as the case may be) and the Technically Evaluated Entity and / or Financially Evaluated Entity (as the case may be) shall be under the direct control or indirectly under the common control of such entity;

1.2 Interpretation:

Save where the contrary is indicated, any reference in this Agreement to:

"Agreement" shall be construed as including a reference to its Schedules, Appendices and Annexures;

"Rupee", "Rupees" and "Rs." shall denote lawful currency of India;

"crore" shall mean a reference to ten million (10,000,000) and a **"lakh"** shall mean a reference to one tenth of a million (1,00,000);

"encumbrance" shall be construed as a reference to a mortgage, charge, pledge, lien or other encumbrance securing any obligation of any person or any other type of preferential arrangement (including, without limitation, title transfer and retention arrangements) having a similar effect;

"holding company" of a company or corporation shall be construed as a reference to any company or corporation of which the other company or corporation is a subsidiary;

"indebtedness" shall be construed so as to include any obligation (whether incurred as principal or surety) for the payment or repayment of money, whether present or future, actual or contingent;

"person" shall have the meaning as defined in Section 2 (49) of the Act;

"subsidiary" of a company or corporation (the holding company) shall be construed as a reference to any company or corporation:

- (i) which is controlled, directly or indirectly, by the holding company, or
- (ii) more than half of the issued share capital of which is beneficially owned, directly or indirectly, by the holding company, or
- (iii) which is a subsidiary of another subsidiary of the holding company,

Transmission Service Agreement

for these purposes, a company or corporation shall be treated as being controlled by another if that other company or corporation is able to direct its affairs and/or to control the composition of its board of directors or equivalent body;

"winding-up", "dissolution", "insolvency", or "reorganization" in the context of a company or corporation shall have the same meaning as defined in the Companies Act, 1956/ Companies Act, 2013 (as the case may be).

- 1.2.1 Words importing the singular shall include the plural and vice versa.
- 1.2.2 This Agreement itself or any other agreement or document shall be construed as a reference to this or to such other agreement or document as it may have been, or may from time to time be, amended, varied, novated, replaced or supplemented.
- 1.2.3 A Law shall be construed as a reference to such Law including its amendments or re-enactments from time to time.
- 1.2.4 A time of day shall, save as otherwise provided in any agreement or document be construed as a reference to Indian Standard Time.
- 1.2.5 Different parts of this Agreement are to be taken as mutually explanatory and supplementary to each other and if there is any inconsistency between or among the parts of this Agreement, they shall be interpreted in a harmonious manner so as to give effect to each part.
- 1.2.6 The tables of contents and any headings or sub-headings in this Agreement have been inserted for ease of reference only and shall not affect the interpretation of this Agreement.
- 1.2.7 All interest payable under this Agreement shall accrue from day to day and be calculated on the basis of a year of three hundred and sixty five (365) days.
- 1.2.8 The words "hereof" or "herein", if and when used in this Agreement shall mean a reference to this Agreement.
- 1.2.9 The contents of Schedule 7 shall be referred to for ascertaining accuracy and correctness of the representations made by the Selected Bidder in Article 17.2.1 hereof.

ARTICLE: 2

2 EFFECTIVENESS AND TERM OF AGREEMENT

2.1 Effective Date:

This Agreement shall be effective from later of the dates of the following events:

The Selected Bidder, on behalf of the TSP, has provided the Contract Performance Guarantee, as per terms of Article 3.1 of this Agreement; and

The Selected Bidder has acquired for the Acquisition Price, one hundred percent (100%) of the equity shareholding of PFC Consulting Limited (PFCCL) in KPS III HVDC TRANSMISSION LIMITED along with all its related assets and liabilities as per the provisions of the Share Purchase Agreement. and

The Agreement is executed and delivered by the Parties;

2.2 Term and Termination:

2.2.1 Subject to Article 2.2.3 and Article 2.4, this Agreement shall continue to be effective in relation to the Project until the Expiry Date, when it shall automatically terminate.

2.2.2 Post the Expiry Date of this Agreement, the TSP shall ensure transfer of Project Assets to CTU or its successors or an agency as decided by the Central Government at zero cost and free from any encumbrance and liability. The transfer shall be completed within 90 days of expiry of this Agreement failing which CTU shall be entitled to take over the Project Assets Suo moto.

2.2.3 This Agreement shall terminate before the Expiry Date in accordance with Article 13 or Article 3.3.2 or Article 3.3.4.

2.3 Conditions prior to the expiry of the Transmission License

2.3.1 In order to continue the Project beyond the expiry of the Transmission License, the TSP shall be obligated to make an application to the Commission at least two (2) years before the date of expiry of the Transmission License, seeking the Commission's approval for the extension of the term of the Transmission License up to the Expiry Date.

2.3.2 The TSP shall timely comply with all the requirements that may be laid down by the Commission for extension of the term of the Transmission License beyond the initial term of twenty-five (25) years & upto the Expiry Date and the TSP shall keep the Nodal Agency fully informed about the progress on its application for extension of the term of the Transmission License.

2.4 Survival:

The expiry or termination of this Agreement shall not affect any accrued rights, obligations/ roles and liabilities of the Parties under this Agreement, including the right to receive liquidated damages as per the terms of this Agreement, nor shall it effect the survival of any continuing obligations/ roles for which this Agreement provides, either expressly or by necessary implication, which are to survive after the Expiry Date or termination including those under Articles 3.3.3, 3.3.5, Article 9.3 (Application of Insurance Proceeds), Article 11 (Force Majeure), Article 13 (Events of Default and Termination), Article 14 (Liability & Indemnification), Article 16 (Governing Law & Dispute Resolution), Article 19 (Miscellaneous).

2.5 Applicability of the provisions of this Agreement

2.5.1 For the purpose of Availability, Target Availability and the computation of Availability, Incentive, Penalty, the provisions provided in this Agreement shall apply and any future modifications in the relevant Rules and Regulations shall not be applicable for this Project.

2.5.2 For the purposes of this Agreement for ISTS systems developed under the tariff based competitive bidding framework, the provisions relating to the definitions (Availability and COD), Article 3 (Contract Performance Guarantee and Conditions Subsequent), Article 5 (Construction of the Project), Article 6 (Connection and Commissioning of the Project), Article 8 (Target Availability and calculation of Availability), Article 11 (Force Majeure), Article 12 (Change in Law), Article 13 (Event of Default), Article 14 (Indemnification), Article 15 (Assignment and Charges), Articles 16.1, 16.2 and 16.4 (Governing Laws and Dispute Resolution) and Article 17 (representation and warranties of the ISTS Licensee) of this agreement shall supersede the corresponding provisions under Sharing Regulations.

ARTICLE: 3

3 CONDITIONS SUBSEQUENT

3.1 Satisfaction of conditions subsequent by the TSP

- 3.1.1 Within ten (10) days from the date of issue of Letter of Intent, the Selected Bidder, shall:
- a. Provide the Contract Performance Guarantee, and
 - b. Acquire, for the Acquisition Price, one hundred percent (100%) equity shareholding of KPS III HVDC TRANSMISSION LIMITED from **PFC Consulting Limited (PFCCL)**, who shall sell to the Selected Bidder, the equity shareholding of KPS III HVDC TRANSMISSION LIMITED, along with all its related assets and liabilities.
 - c. Execute this Agreement;

The TSP shall, within five (5) working days from the date of acquisition of SPV by the Selected Bidder, undertake to apply to the Commission for the grant of Transmission License and for the adoption of tariff as required under section-63 of the Electricity Act.

The Selected Bidder, on behalf of the TSP, will provide to the **Central Transmission Utility of India Limited** (being the Nodal Agency) the Contract Performance Guarantee for an amount of **Rs. 477.48 Crore** (Rupees Four Hundred Seventy Seven crore and Fourty Eight Lakh Only)

- 3.1.2 The Contract Performance Guarantee shall be initially valid for a period up to three (3) months after the Scheduled COD of the Project and shall be extended from time to time to be valid for a period up to three (3) months after the COD of the Project. In case the validity of the Contract Performance Guarantee is expiring before the validity specified in this Article, the TSP shall, at least thirty (30) days before the expiry of the Contract Performance Guarantee, replace the Contract Performance Guarantee with another Contract Performance Guarantee or extend the validity of the existing Contract Performance Guarantee until the validity period specified in this Article.
- 3.1.3 The TSP agrees and undertakes to duly perform and complete the following activities within six (6) months from the Effective Date (except for c) below), unless such completion is affected due to any Force Majeure Event, or if any of the activities is specifically waived in writing by the Nodal Agency:
- a. To obtain the Transmission License for the Project from the Commission;
 - b. To obtain the order for adoption of Transmission Charges by the Commission, as required under Section 63 of the Electricity Act 2003;

Transmission Service Agreement

- c. To submit to the Nodal Agency, CEA & Independent Engineer, the Project Execution Plan, immediately after award of contract(s) and maximum within one hundred and twenty (120) days from the Effective Date. Also, an approved copy each of Manufacturing Quality Plan (MQP) and Field Quality Plan (FQP) would be submitted to Independent Engineer & Nodal Agency in the same time period. The TSP's Project Execution Plan should be in conformity with the Scheduled COD as specified in Schedule 2 of this Agreement, and shall bring out clearly the organization structure, time plan and methodology for executing the Project, award of major contracts, designing, engineering, procurement, shipping, construction, testing and commissioning to commercial operation;
- d. To submit to the Nodal Agency, CEA & Independent Engineer a detailed bar (GANTT) chart of the Project outlining each activity (taking longer than one Month), linkages as well as durations;
- e. To submit to the Nodal Agency, CEA & Independent Engineer detailed specifications of conductor meeting the functional specifications specified in RFP;
- f. To achieve Financial Closure;
- g. To provide an irrevocable letter to the Lenders duly accepting and acknowledging the rights provided to the Lenders under the provisions of Article 15.3 of this Agreement and all other RFP Project Documents;
- h. To award the Engineering, Procurement and Construction contract ("EPC contract") for the design and construction of the Project and shall have given to such Contractor an irrevocable notice to proceed; and
- i. To sign the Agreement(s) required, if any, under Sharing Regulations.

3.2 Recognition of Lenders' Rights by the Nodal Agency

- 3.2.1 The Nodal Agency hereby accepts and acknowledges the rights provided to the Lenders as per Article 15.3 of this Agreement and all other RFP Project Documents.

3.3 Consequences of non-fulfilment of conditions subsequent

- 3.3.1 If any of the conditions specified in Article 3.1.3 is not duly fulfilled by the TSP even within three (3) Months after the time specified therein, then on and from the expiry of such period and until the TSP has satisfied all the conditions specified in Article 3.1.3, the TSP shall, on a monthly basis, be liable to furnish to **Central Transmission Utility of India Limited (being the Nodal Agency)** additional Contract Performance Guarantee of **Rs. 47.75 Crore (Rupees Fourty Seven Crore and Seventy Five Lakh Only)** within two (2) Business Days of expiry of every such Month. Such additional Contract Performance Guarantee shall be provided to **Central Transmission Utility of India Limited (being the Nodal Agency)** in the manner provided in Article 3.1.1 and

Transmission Service Agreement

shall become part of the Contract Performance Guarantee and all the provisions of this Agreement shall be construed accordingly. **Central Transmission Utility of India Limited (being the Nodal Agency)** shall be entitled to hold and / or invoke the Contract Performance Guarantee, including such additional Contract Performance Guarantee, in accordance with the provisions of this Agreement.

3.3.2 Subject to Article 3.3.4, if:

- (i) the fulfilment of any of the conditions specified in Article 3.1.3 is delayed beyond nine (9) Months from the Effective Date and the TSP fails to furnish additional Contract Performance Guarantee to the Nodal Agency in accordance with Article 3.3.1 hereof; or
- (ii) the TSP furnishes additional Performance Guarantee to the Nodal Agency in accordance with Article 3.3.1 hereof but fails to fulfil the conditions specified in Article 3.1.3 within a period of twelve (12) months from the Effective Date,

the Nodal Agency shall have the right to terminate this Agreement, by giving a Termination Notice to the TSP, in writing, of at least seven (7) days, with a copy to CEA and the Lenders' Representative in order to enable the Lenders to exercise right of substitution in accordance with Article 15.3 of this Agreement.

3.3.3 If the Nodal Agency elects to terminate this Agreement as per the provisions of Article 3.3.1, the TSP shall be liable to pay to the Nodal Agency an amount of **Rs. 477.48** (Rupees Four Hundred Seventy Seven Crore and Fourty Eight Lakh only) as liquidated damages. The Nodal Agency shall be entitled to recover this amount of damages by invoking the Contract Performance Guarantee to the extent of liquidated damages, which shall be required by the Nodal Agency, and the balance shall be returned to TSP, if any.

It is clarified for removal of doubt that this Article shall survive the termination of this Agreement.

3.3.4 In case of inability of the TSP to fulfil the conditions specified in Article 3.1.3 due to any Force Majeure Event, the time period for fulfilment of the condition subsequent as mentioned in Article 3.1.3, may be extended for a period of such Force Majeure Event. Alternatively, if deemed necessary, this Agreement may be terminated by the Nodal Agency by giving a Termination Notice to the TSP, in writing, of at least seven (7) days, with a copy to CEA and the Lenders' Representative in order to enable the Lenders to exercise right of substitution in accordance with Article 15.3 of this Agreement and the Contract Performance Guarantee shall be returned as per the provisions of Article 6.5.1.

Transmission Service Agreement

Provided, that due to the provisions of this Article 3.3.4, any increase in the time period for completion of conditions subsequent mentioned under Article 3.1.3, shall lead to an equal increase in the time period for the Scheduled COD. If the Scheduled COD is extended beyond a period of one hundred eighty (180) days due to the provisions of this Article 3.3.4, the TSP will be allowed to recover the interest cost during construction corresponding to the period exceeding one hundred eighty (180) days by adjustment in the Transmission Charges in accordance with Schedule 9.

- 3.3.5 Upon termination of this Agreement as per Articles 3.3.1 and 3.3.4, the Nodal Agency may take steps to bid out the Project again.
- 3.3.6 The Nodal agency, on the failure of the TSP to fulfil its obligations, if it considers that there are sufficient grounds for so doing, apart from invoking the Contract Performance Guarantee under para 3.3.3 may also initiate proceedings for blacklisting the TSP as per provisions of Article 13.2 of TSA.

3.4 Progress Reports

The TSP shall notify the Nodal Agency and CEA in writing at least once a Month on the progress made in satisfying the conditions subsequent in Articles 3.1.3.

ARTICLE: 4

4 DEVELOPMENT OF THE PROJECT

4.1 TSP's obligations in development of the Project:

Subject to the terms and conditions of this Agreement, the TSP at its own cost and expense shall observe, comply with, perform, undertake and be responsible:

- a. for procuring and maintaining in full force and effect all Consents, Clearances and Permits, required in accordance with Law for development of the Project;
- b. for financing, constructing, owning and commissioning each of the Element of the Project for the scope of work set out in Schedule 1 of this Agreement in accordance with:
 - i. the Electricity Act and the Rules made thereof;
 - ii. the Grid Code;
 - iii. the CEA Regulations applicable, and as amended from time to time, for Transmission Lines and sub-stations:
 - the Central Electricity Authority (Technical Standards for Connectivity to the Grid) Regulations, 2007;
 - Central Electricity Authority (Technical Standards for construction of Electrical Plants and Electric Lines) Regulation, 2010;
 - Central Electricity Authority (Grid Standard) Regulations, 2010;
 - Central Electricity Authority (Safety requirements for construction, operation and maintenance of Electrical Plants and Electrical Lines) Regulation, 2011;
 - Central Electricity Authority (Measures relating to Safety and Electricity Supply) Regulation, 2010;
 - Central Electricity Authority (Technical Standards for Communication System in Power System Operation) Regulations, 2020.
 - iv. Safety/ security Guidelines laid down by the Government;
 - v. Prudent Utility Practices, relevant Indian Standards and the Law;not later than the Scheduled COD as per Schedule 2 of this Agreement;
- c. for entering into a Connection Agreement with the concerned parties in accordance with the Grid Code.
- d. for owning the Project throughout the term of this Agreement free and clear of any encumbrances except those expressly permitted under Article 15 of this Agreement;
- e. to co-ordinate and liaise with concerned agencies and provide on a timely basis

Transmission Service Agreement

- relevant information with regard to the specifications of the Project that may be required for interconnecting the Project with the Interconnection Facilities;
- f. for providing all assistance to the Arbitrators as they may require for the performance of their duties and responsibilities;
 - g. to provide to the Nodal Agency and CEA, on a monthly basis, progress reports with regard to the Project and its execution (in accordance with prescribed form) to enable the CEA to monitor and co-ordinate the development of the Project matching with the Interconnection Facilities;
 - h. to comply with Ministry of Power order no. 25-11/6/2018 – PG dated 02.07.2020 as well as other Guidelines issued by Govt. of India pertaining to this;
 - i. to procure the products associated with the Transmission System as per provisions of Public Procurement (Preference to Make in India) orders issued by Ministry of Power vide orders No. 11/5/2018 - Coord. dated 28.07.2020 for transmission sector, as amended from time to time read with Department for Promotion of Industry and Internal Trade (DPIIT) orders in this regard (Procuring Entity as defined in above orders shall deemed to have included Selected Bidder and/ or TSP).

Also, to comply with Department of Expenditure, Ministry of Finance vide Order (Public Procurement No 1) bearing File No. 6/18/2019-PPD dated 23.07.2020, Order (Public Procurement No 2) bearing File No. 6/18/2019-PPD dated 23.07.2020 and Order (Public Procurement No. 3) bearing File No. 6/18/2019-PPD, dated 24.07.2020, as amended from time to time, regarding public procurement from a bidder of a country, which shares land border with India;

- j. to submit to Nodal Agency information in the prescribed format [To be devised by Nodal Agency] for ensuring compliance to Article 4.1 i) above.
- k. to comply with all its obligations undertaken in this Agreement.

4.2 Roles of the Nodal Agency in implementation of the Project:

4.2.1 Subject to the terms and conditions of this Agreement, the Nodal Agency shall be the holder and administrator of this Agreement and shall inter alia:

- a. appoint an Independent Engineer within 90 days of the Effective Date
- b. provide letters of recommendation to the concerned Indian Governmental Instrumentality, as may be requested by the TSP from time to time, for obtaining the Consents, Clearances and Permits required for the Project;
- c. coordinate among TSP and upstream/downstream entities in respect of Interconnection Facilities; and
- d. monitor the implementation of the Agreement and take appropriate action for breach thereof including revocation of guarantees, cancellation of Agreement, blacklisting etc

Transmission Service Agreement

- e. provide all assistance to the Arbitrators as required for the performance of their duties and responsibilities; and
- f. perform any other responsibility (ies) as specified in this Agreement.

4.3 Time for Commencement and Completion:

- a. The TSP shall take all necessary steps to commence work on the Project from the Effective Date of the Agreement and shall achieve Scheduled COD of the Project in accordance with the time schedule specified in Schedule 2 of this Agreement;
- b. The COD of each Element of the Project shall occur no later than the Scheduled COD or within such extended time to which the TSP shall be entitled under Article 4.4 hereto.

4.4 Extension of time:

- 4.4.1 In the event that the TSP is unable to perform its obligations for the reasons solely attributable to the Nodal Agency, the Scheduled COD shall be extended, by a 'day to day' basis, subject to the provisions of Article 13.
- 4.4.2 In the event that an Element or the Project cannot be commissioned by its Scheduled COD on account of any Force Majeure Event as per Article 11, the Scheduled COD shall be extended, by a 'day to day' basis for a period of such Force Majeure Event. Alternatively, if deemed necessary, the Nodal Agency may terminate the Agreement as per the provisions of Article 13.4 by giving a Termination Notice to the TSP, in writing, of at least seven (7) days, with a copy to CEA and the Lenders' Representative in order to enable the Lenders to exercise right of substitution in accordance with Article 15.3 of this Agreement.
- 4.4.3 If the Parties have not agreed, within thirty (30) days after the affected Party's performance has ceased to be affected by the relevant circumstance, on how long the Scheduled COD should be deferred by, any Party may raise the Dispute to be resolved in accordance with Article 16.

4.5 Metering Arrangements:

- 4.5.1 The TSP shall comply with all the provisions of the IEGC and the Central Electricity Authority (Installation and Operation of Meters) Regulations, 2006 as amended from time to time, with regard to the metering arrangements for the Project. The TSP shall fully cooperate with the CTU / STU / RLDC and extend all necessary assistance in taking meter readings.

4.6 Interconnection Facilities:

- 4.6.1 Subject to the terms and conditions of this Agreement, the TSP shall be responsible for connecting the Project with the interconnection point(s) specified in Schedule 1 of

Transmission Service Agreement

this Agreement. The Interconnection Facilities shall be developed as per the scope of work and responsibilities assigned in Schedule 1 of this Agreement. The Nodal Agency shall be responsible for coordinating to make available the Interconnection Facilities.

- 4.6.2 In order to remove any doubts, it is made clear that the obligation of the TSP within the scope of the project is to construct the Project as per Schedule-1 of this Agreement and in particular to connect it to the Interconnection Facilities as specified in this Agreement.

ARTICLE: 5

5 CONSTRUCTION OF THE PROJECT

5.1 TSP's Construction Responsibilities:

- 5.1.1 The TSP, at its own cost and expense, shall be responsible for designing, constructing, erecting, testing and commissioning each Element of the Project by the Scheduled COD in accordance with the Regulations and other applicable Laws specified in Article 4.1 of this Agreement.
- 5.1.2 The TSP acknowledges and agrees that it shall not be relieved from any of its obligations under this Agreement or be entitled to any extension of time or any compensation whatsoever by reason of the unsuitability of the Site or Transmission Line route(s).
- 5.1.3 The TSP shall be responsible for obtaining all Consents, Clearances and Permits related but not limited to road / rail / river / canal / power line / crossings, Power and Telecom Coordination Committee (PTCC), defence, civil aviation, right of way / way-leaves and environmental & forest clearances from relevant authorities required for developing, financing, constructing, maintaining/ renewing all such Consents, Clearances and Permits in order to carry out its obligations under this Agreement in general and shall furnish to the Nodal Agency such copy/ies of each Consents, Clearances and Permits, on demand. Nodal Agency shall provide letters of recommendation to the concerned Indian Governmental Instrumentality, as may be requested by the TSP from time to time, for obtaining the Consents, Clearances and Permits required for the Project.
- 5.1.4 The TSP shall be responsible for:
- a) acquisition of land for location specific substations, switching stations or HVDC terminal or inverter stations. Also, the actual location of substations, switching stations or HVDC terminal or inverter stations shall not be beyond 1 Km radius of the location proposed by the BPC in the survey report;
 - b) final selection of Site including its geo-technical investigation;
 - c) survey and geo-technical investigation of line route in order to determine the final route of the Transmission Lines;
 - d) seeking access to the Site and other places where the Project is being executed, at its own risk and costs, including payment of any crop, tree compensation or any other compensation as may be required.
- 5.1.5 In case the Project involves any resettlement and rehabilitation, the resettlement and rehabilitation package will be implemented by the State Government authorities, for which the costs is to be borne by the TSP and no changes would be allowed in the

Transmission Charges on account of any variation in the resettlement and rehabilitation cost. The TSP shall provide assistance on best endeavour basis, in implementation of the resettlement and rehabilitation package, if execution of such package is in the interest of expeditious implementation of the Project and is beneficial to the Project affected persons.

5.2 Appointing Contractors:

- 5.2.1 The TSP shall conform to the requirements as provided in this Agreement while appointing Contractor(s) for procurement of goods & services.
- 5.2.2 The appointment of such Contractor(s) shall neither relieve the TSP of any of its obligations under this Agreement nor make the Nodal Agency liable for the performance of such Contractor(s).

5.3 Monthly Progress Reporting:

The TSP shall provide to the CEA, Nodal Agency & Independent Engineer, on a monthly basis, progress reports along with likely completion date of each Element with regard to the Project and its execution (in accordance with prescribed form). The Nodal Agency/ CEA shall monitor the development of the Project for its timely completion for improving and augmenting the electricity system as a part of its statutory responsibility.

5.4 Quality of Workmanship:

The TSP shall ensure that the Project is designed, built and completed in a good workmanship using sound engineering and construction practices, and using only materials and equipment that are new and manufactured as per the MQP and following approved FQP for erection, testing & commissioning and complying with Indian /International Standards such that, the useful life of the Project will be at least thirty five (35) years from the COD of the Project.

The TSP shall ensure that all major substation equipment / component (e.g. transformers, reactors, Circuit Breakers, Instrument Transformers (IT), Surge Arresters (SA), Protection relays, clamps & connectors etc.), equipment in terminal stations of HVDC installations including Thyristor/ IGBT valves, Converter Transformers, smoothing reactors, Transformer bushings and wall bushings, GIS bus ducts, towers and gantry structures and transmission towers or poles and line materials (conductors, earthwire, OPGW, insulator, accessories for conductors, OPGW & earthwires, hardware fittings for insulators, aviation lights etc), facilities and system shall be designed, constructed and tested (Type test, Routine tests, Factory Acceptance Test (FAT)) in accordance with relevant CEA Regulations and Indian Standards. In case Indian Standards for any particular equipment/ system/ process is not available, IEC/ IEEE or equivalent International Standards and Codes shall be followed.

5.5 Progress Monitoring & Quality Assurance:

- 5.5.1 The Project Execution Plan submitted by the TSP in accordance with Article 3.1.3 c) shall comprise of detailed schedule of all the equipments/items /materials required for the Project, right from procurement of raw material till the dispatch from works and receipt at the site. Further, it should also include various stages of the construction schedule up to the commissioning of the Project.
- 5.5.2 Nodal Agency, CEA & Independent Engineer shall have access at all reasonable times to the Site and to the Manufacturer's works and to all such places where the Project is being executed.
- 5.5.3 Independent Engineer shall ensure conformity of the conductor specifications with the functional specifications specified in RFP.
- 5.5.4 The Independent Engineer shall monitor the following during construction of the Project:
- a) Quality of equipments, material, foundation, structures and workmanship etc. as laid down in Article 5.4 and 6.1.4 of the TSA. Specifically, quality of Sub-station equipments, transmission line material and workmanship etc. would be checked in accordance with the Article 5.4.
 - b) Progress in the activities specified in Condition Subsequent
 - c) Verification of readiness of the elements including the statutory clearances & completion of civil works, fixing of all components and finalisation of punch points (if any) prior to charging of the elements
 - d) Progress of construction of substation and Transmission Lines
- 5.5.5 The progress shall be reviewed by the Independent Engineer against the Project Execution Plan. The Independent Engineer shall prepare its report on monthly basis and submit the same to Nodal Agency highlighting the progress achieved till the end of respective month vis-à-vis milestone activities, areas of concern, if any, which may result in delay in the timely completion of the Project. Based on the progress, Nodal Agency and/ or CEA shall issue written instructions to the TSP to take corrective measures, as may be prudent for the timely completion of the Project. In case of any deficiency, the Nodal Agency would be at liberty to take action in accordance with the procedure of this Agreement.
- 5.5.6 For any delay in commissioning any critical Element(s), as identified in Schedule 1 & Schedule 2 of this Agreement, beyond a period of 45 days shall lead to a sequestration of 10% of the Contract Performance Guarantee.

5.6 Site regulations and Construction Documents

The TSP shall abide by the Safety Rules and Procedures as mentioned in Schedule 3 of this Agreement

The TSP shall retain at the Site and make available for inspection at all reasonable times, copies of the Consents, Clearances and Permits, construction drawings and other documents related to construction.

5.7 Supervision of work:

The TSP shall provide all necessary superintendence for execution of the Project and its supervisory personnel shall be available to provide full-time superintendence for execution of the Project. The TSP shall provide skilled personnel who are experienced in their respective fields.

5.8 Remedial Measures:

The TSP shall take all necessary actions for remedying the shortfall in achievement of timely progress in execution of the Project, if any, as intimated by the Independent Engineer and/ or CEA and/ or the Nodal Agency. However, such intimation by the Independent Engineer and/ or CEA and/ or the Nodal Agency and the subsequent effect of such remedial measures carried out by the TSP shall not relieve the TSP of its obligations in the Agreement. Independent Engineer and/ or CEA and/ or the Nodal Agency may carry out random inspections during the Project execution, as and when deemed necessary by it. If the shortfalls as intimated to the TSP are not remedied to the satisfaction of the CEA and/ or the Nodal Agency, this Agreement may be terminated by the Nodal Agency by giving a Termination Notice to the TSP, in writing, of at least seven (7) days, with a copy to CEA and the Lenders' Representative in order to enable the Lenders to exercise right of substitution in accordance with Article 15.3 of this Agreement .

ARTICLE: 6

6 CONNECTION AND COMMISSIONING OF THE PROJECT

6.1 Connection with the Inter-Connection Facilities:

- 6.1.1 The TSP shall give the RLDC(s), CTU, / STU, as the case may be, and any other agencies as required, at least sixty (60) days advance written notice of the date on which it intends to connect an Element of the Project, which date shall not be earlier than its Scheduled COD or Schedule COD extended as per Article 4.4.1 & 4.4.2 of this Agreement, unless mutually agreed to by Parties. Further, any preponing of COD of any element prior to Scheduled COD must be approved by the Nodal Agency.
- 6.1.2 The RLDC / SLDC (as the case may be) or the CTU / STU (as the case may be), for reasonable cause, including non-availability of Interconnection Facilities as per Article 4.2, can defer the connection for up to fifteen (15) days from the date notified by the TSP pursuant to Article 6.1.1, if it notifies to the TSP in writing, before the date of connection, of the reason for the deferral and when the connection is to be rescheduled. However, no such deferment on one or more occasions would be for more than an aggregate period of thirty (30) days. Further, the Scheduled COD would be extended as required, for all such deferments on “day to day” basis.
- 6.1.3 Subject to Articles 6.1.1 and 6.1.2, any Element of Project may be connected with the Interconnection Facilities when:
- a) it has been completed in accordance with this Agreement and the Connection Agreement;
 - b) it meets the Grid Code, Central Electricity Authority (Technical Standards for Connectivity to the Grid) Regulations, 2007 as amended from time to time and all other Indian legal requirements, and
 - c) The TSP has obtained the approval in writing of the Electrical Inspector certifying that the Element is ready from the point of view of safety of supply and can be connected with the Interconnection Facilities.
- 6.1.4 It has satisfactorily met all the testing requirements as per Articles 6.1.4
- 6.1.5 Site Acceptance Test (SAT)/ pre-commissioning tests of all major substation equipment, component, system, facilities shall be successfully carried out before commissioning. The Type tests, FAT and SAT reports should be available at the substation / terminal station of HVDC installations for ready reference of operation and maintenance staff and has to be made available to the Independent Engineer appointed for quality monitoring or their authorised representatives, as and when they wish to examine the same.

6.2 Commercial Operation:

- 6.2.1 An Element of the Project shall be declared to have achieved COD twenty four (24) hours following the connection of the Element with the Interconnection Facilities pursuant to Article 6.1 or seven (7) days after the date on which it is declared by the TSP to be ready for charging but is not able to be charged for reasons not attributable to the TSP subject to Article 6.1.2.

Provided that an Element shall be declared to have achieved COD only after all the Element(s), if any, which are pre-required to have achieved COD as defined in Schedule 2 of this Agreement, have been declared to have achieved their respective COD.

- 6.2.2 Once any Element of the Project has been declared to have achieved deemed COD as per Article 6.2.1 above, such Element of the Project shall be deemed to have Availability equal to the Target Availability till the actual charging of the Element and to this extent, TSP shall be eligible for the Monthly Transmission Charges applicable for such Element

6.3 Compensation for Direct Non Natural Force Majeure Event or Indirect Non Natural Force Majeure Event or Natural Force Majeure Event (affecting the Nodal Agency)

- 6.3.1 If the TSP is otherwise ready to connect the Element(s) of the Project and has given due notice, as per provisions of Article 6.1.1, to the concerned agencies of the date of intention to connect the Element(s) of the Project, where such date is not before the Scheduled COD, but is not able to connect the Element(s) of the Project by the said date specified in the notice, due to Direct Non Natural Force Majeure Event or Indirect Non Natural Force Majeure Event or Natural Force Majeure Event affecting the Nodal Agency, provided such Direct Non Natural Force Majeure Event or Indirect Non Natural Force Majeure Event or Natural Force Majeure Event affecting the Nodal Agency has continued for a period of more than three (3) continuous or non-continuous Months, the TSP shall, until the effects of the Direct Non Natural Force Majeure Event or of Indirect Non Natural Force Majeure Event or Natural Force Majeure Event affecting the Nodal Agency no longer prevent the TSP from connecting the Element(s) of the Project, be deemed to have achieved COD relevant to that date and to this extent, be deemed to have been providing Transmission Service with effect from the date notified, and shall be treated as follows:

- a) In case of delay due to Direct Non Natural Force Majeure Event, TSP is entitled for Transmission Charges calculated on Target Availability for the period of such events in excess of three (3) continuous or non continuous Months in the manner provided in (c) below.
- b) In case of delay due to Indirect Non Natural Force Majeure Event or Natural Force Majeure Event affecting the Nodal Agency, TSP is entitled for payment for debt service which is due under the Financing Agreements, subject to a

Transmission Service Agreement

maximum of Transmission Charges calculated on Target Availability, for the period of such events in excess of three (3) continuous or non continuous Months in the manner provided in (c) below.

- c) In case of delay due to Direct Non Natural Force Majeure Event or Indirect Non Natural Force Majeure Event or Natural Force Majeure Event affecting the Nodal Agency, the TSP is entitled for payments mentioned in (a) and (b) above, after commencement of Transmission Service, in the form of an increase in Transmission Charges. These amounts shall be paid from the date, being the later of a) the date of cessation of such Indirect Non Natural Force Majeure Event or Natural Force Majeure Event affecting the Nodal Agency and b) the completion of sixty (60) days from the receipt of the Financing Agreements by the Nodal Agency from the TSP.

Provided such increase in Transmission Charges shall be so as to put the TSP in the same economic position as the TSP would have been in case the TSP had been paid amounts mentioned in (a) and (b) above in a situation where the Force Majeure Event had not occurred.

For the avoidance of doubt, it is clarified that the charges payable under this Article 6.3.1 shall be recovered as per Sharing Regulations.

6.4 Liquidated Damages for Delay in achieving COD of Project:

- 6.4.1 If the TSP fails to achieve COD of any Element of the Project or the Project, by the Element's / Project's Scheduled COD or such Scheduled COD as extended under Articles 4.4.1 and 4.4.3, then the TSP shall pay to the Nodal Agency, a sum equivalent to 3.33% of Monthly Transmission Charges applicable for the Element of the Project [in case where no Elements have been defined, to be on the Project as a whole] / Project, for each day of delay up to sixty (60) days of delay and beyond that time limit, at the rate of five percent (5%) of the Monthly Transmission Charges applicable to such Element / Project, as liquidated damages for such delay and not as penalty, without prejudice to any rights of the Nodal Agency under the Agreement.

- 6.4.2 The TSP's maximum liability under this Article 6.4 shall be limited to the amount of liquidated damages calculated in accordance with Article 6.4.1 for and up to six (6) months of delay for the Element or the Project.

Provided that, in case of failure of the TSP to achieve COD of the Element of the Project even after the expiry of six (6) months from its Scheduled COD, the provisions of Article 13 shall apply.

- 6.4.3 The TSP shall make payment to the Nodal Agency of the liquidated damages calculated pursuant to Article 6.4.1 within ten (10) days of the earlier of:

- a) the date on which the applicable Element achieves COD; or

b) the date of termination of this Agreement.

The payment of such damages shall not relieve the TSP from its obligations to complete the Project or from any other obligation and liabilities under the Agreement.

6.4.4 If the TSP fails to pay the amount of liquidated damages to the Nodal Agency within the said period of ten (10) days, the Nodal Agency shall be entitled to recover the said amount of the liquidated damages by invoking the Contract Performance Guarantee. If the then existing Contract Performance Guarantee is for an amount which is less than the amount of the liquidated damages payable by the TSP to the Nodal Agency under this Article 6.3 and the TSP fails to make payment of the balance amount of the liquidated damages not covered by the Contract Performance Guarantee, then such balance amount shall be deducted from the Transmission Charges payable to the TSP. The right of the Nodal Agency to encash the Contract Performance Guarantee is without prejudice to the other rights of the Nodal Agency under this Agreement.

6.4.5 For avoidance of doubt, it is clarified that amount payable by TSP under this Article is over and above the penalty payable by TSP under Article 5.5.6 of this Agreement.

6.5 Return of Contract Performance Guarantee

6.5.1 The Contract Performance Guarantee as submitted by TSP in accordance with Article 3.1.1 shall be released by the Nodal Agency within three (3) months from the COD of the Project. In the event of delay in achieving Scheduled COD of any of the Elements by the TSP (otherwise than due to reasons as mentioned in Article 3.1.3 or Article 11) and consequent part invocation of the Contract Performance Guarantee by the Nodal Agency, Nodal Agency shall release the Contract Performance Guarantee, if any remaining unadjusted, after the satisfactory completion by the TSP of all the requirements regarding achieving the Scheduled COD of the remaining Elements of the Project. It is clarified that the Nodal Agency shall also return / release the Contract Performance Guarantee in the event of (i) applicability of Article 3.3.1 to the extent the Contract Performance Guarantee is valid for an amount in excess of **Rs 477.48** Crore (Rupees Four Hundred Seventy Seven crore and Fourty- Eight Lakh Only), or (ii) termination of this Agreement by the Nodal Agency as mentioned under Article 3.3.4 of this Agreement.

6.5.2 The release of the Contract Performance Guarantee shall be without prejudice to other rights of the Nodal Agency under this Agreement.

ARTICLE: 7

7 OPERATION AND MAINTENANCE OF THE PROJECT

7.1 Operation and Maintenance of the Project:

The TSP shall be responsible for ensuring that the Project is operated and maintained in accordance with the regulations made by the Commission and CEA from time to time and provisions of the Act.

ARTICLE: 8

8 AVAILABILITY OF THE PROJECT

8.1 Calculation of Availability of the Project:

Calculation of Availability for the Elements and for the Project, as the case may be, shall be as per **Appendix –IV to Central Electricity Regulatory Commission (Terms and Conditions of Tariff) Regulations, 2024**, as applicable on the Bid Deadline and as appended in Schedule 6 of this Agreement.

8.2 Target Availability:

The Target Availability of each Element and the Project shall be **98%**.

Payment of monthly Transmission charges based on actual availability will be calculated as per para 1.2 of Schedule 4 of this Agreement.

If the availability of any Element or the Project is below the Target Availability, for six consecutive months in a Contract Year, the DIC(s) or the Nodal Agency may issue a show cause notice to the TSP, asking them to show cause as to why the Transmission Service Agreement be not terminated, and if no satisfactory cause is shown it may terminate the Agreement. If the Nodal Agency is of the opinion that the transmission system is of critical importance, it may carry out or cause to carry the operation and maintenance of transmission system at the risk and cost of TSP.

ARTICLE: 9

9 INSURANCES

9.1 Insurance:

- 9.1.1 The TSP shall effect and maintain or cause to be effected and maintained during the Construction Period and the Operating Period, adequate Insurances against such risks, with such deductibles including but not limited to any third party liability and endorsements and co-beneficiary/insured, as may be necessary under
- a. any of the Financing Agreements,
 - b. the Laws, and
 - c. in accordance with Prudent Utility Practices.

The Insurances shall be taken effective from a date prior to the date of the Financial Closure till the Expiry Date.

9.2 Evidence of Insurance cover:

- 9.2.1 The TSP shall furnish to the Nodal Agency copies of certificates and policies of the Insurances, as and when the Nodal Agency may seek from the TSP as per the terms of Article 9.1

9.3 Application of Insurance Proceeds:

- 9.3.1 Save as expressly provided in this Agreement, the policies of Insurances and the Financing Agreements, the proceeds of any insurance claim made due to loss or damage to the Project or any part of the Project shall be first applied to reinstatement, replacement or renewal of such loss or damage.
- 9.3.2 If a Natural Force Majeure Event renders the Project no longer economically and technically viable and the insurers under the Insurances make payment on a “total loss” or equivalent basis, the portion of the proceeds of such Insurance available to the TSP (after making admissible payments to the Lenders as per the Financing Agreements) shall be allocated only to the TSP. Nodal Agency and / or concerned Designated ISTS Customers shall have no claim on such proceeds of the Insurance.
- 9.3.3 Subject to the requirements of the Lenders under the Financing Agreements, any dispute or difference between the Parties as to whether the Project is no longer economically and technically viable due to a Force Majeure Event or whether that event was adequately covered in accordance with this Agreement by the Insurances shall be determined in accordance with Article 16.

9.4 Effect on liability of the Nodal Agency / Designated ISTS Customers

- 9.4.1 The Nodal Agency and / or the Designated ISTS Customers shall have no financial obligations or liability whatsoever towards the TSP in respect of this Article 9.

ARTICLE: 10

10 BILLING AND PAYMENT OF TRANSMISSION CHARGES

10.1 Subject to provisions of this Article 10, the Monthly Transmission Charges shall be paid to the TSP, in Indian Rupees, on monthly basis as per the provisions of the Sharing Regulations, from the date on which an Element(s) has achieved COD until the Expiry Date of this Agreement, unless terminated earlier and in line with the provisions of Schedule 4 of this Agreement.

10.2 Calculation of Monthly Transmission Charges:

The Monthly Transmission Charges for each Contract Year including Incentive & Penalty payment shall be calculated in accordance with the provisions of Schedule 4 of this Agreement.

10.3 Rebate & Late Payment Surcharge:

The rebate and late payment surcharge shall be governed as per Sharing Regulations.

10.4 Disputed Bills, Default in payment by the Designated ISTS Customers & Annual Reconciliation:

Any Disputed Bill, Default in payment by the Designated ISTS Customers & Annual Reconciliation shall be governed as per Sharing Regulations.

ARTICLE: 11

11 FORCE MAJEURE

11.1 Definitions

11.1.1 The following terms shall have the meanings given hereunder.

11.2 Affected Party

11.2.1 An Affected Party means any Party whose performance has been affected by an event of Force Majeure.

11.2.2 Any event of Force Majeure shall be deemed to be an event of Force Majeure affecting the TSP only if the Force Majeure event affects and results in, late delivery of machinery and equipment for the Project or construction, completion, commissioning of the Project by Scheduled COD and/or operation thereafter;

11.3 Force Majeure

A 'Force Majeure' means any event or circumstance or combination of events and circumstances including those stated below that wholly or partly prevents or unavoidably delays an Affected Party in the performance of its obligations/ roles under this Agreement, but only if and to the extent that such events or circumstances are not within the reasonable control, directly or indirectly, of the Affected Party and could not have been avoided if the Affected Party had taken reasonable care or complied with Prudent Utility Practices:

a) Natural Force Majeure Events:

- i. act of God, including, but not limited to drought, fire and explosion (to the extent originating from a source external to the Site), earthquake, volcanic eruption, landslide, flood, cyclone, typhoon, tornado, or exceptionally adverse weather conditions, which are in excess of the statistical measures for the last hundred (100) years; and
- ii. epidemic/ pandemic notified by Indian Governmental Instrumentality.

b) Non-Natural Force Majeure Events :

- i. Direct Non–Natural Force Majeure Events
 - Nationalization or compulsory acquisition by any Indian Governmental Instrumentality of any material assets or rights of the Affected Party; or
 - the unlawful, unreasonable or discriminatory revocation of, or refusal to renew, any Consents, Clearances and Permits required by the Affected Party to perform their obligations/ roles under the RFP Project Documents or any

Transmission Service Agreement

unlawful, unreasonable or discriminatory refusal to grant any other Consents, Clearances and Permits required for the development/ operation of the Project, provided that a Competent Court of Law declares the revocation or refusal to be unlawful, unreasonable and discriminatory and strikes the same down; or

- any other unlawful, unreasonable or discriminatory action on the part of an Indian Governmental Instrumentality which is directed against the Project, provided that a Competent Court of Law declares the action to be unlawful, unreasonable and discriminatory and strikes the same down.

ii. Indirect Non - Natural Force Majeure Events

- act of war (whether declared or undeclared), invasion, armed conflict or act of foreign enemy, blockade, embargo, revolution, riot, insurrection, terrorist or military action; or
- radio active contamination or ionising radiation originating from a source in India or resulting from any other Indirect Non Natural Force Majeure Event mentioned above, excluding circumstances where the source or cause of contamination or radiation is brought or has been brought into or near the Site by the Affected Party or those employed or engaged by the Affected Party; or
- industry-wide strikes and labour disturbances, having a nationwide impact in India.

11.4 Force Majeure Exclusions

11.4.1 Force Majeure shall not include (i) any event or circumstance which is within the reasonable control of the Parties and (ii) the following conditions, except to the extent that they are consequences of an event of Force Majeure:

- a) Unavailability, late delivery, or changes in cost of the machinery, equipment, materials, spare parts etc. for the Project;
- b) Delay in the performance of any Contractors or their agents;
- c) Non-performance resulting from normal wear and tear typically experienced in transmission materials and equipment;
- d) Strikes or labour disturbance at the facilities of the Affected Party;
- e) Insufficiency of finances or funds or the Agreement becoming onerous to perform; and
- f) Non-performance caused by, or connected with, the Affected Party's:

Transmission Service Agreement

- i. negligent or intentional acts, errors or omissions;
 - ii. failure to comply with an Indian Law; or
 - iii. breach of, or default under this Agreement or any Project Documents.
- g) Any error or omission in the survey report provided by BPC during the bidding process.

11.5 Notification of Force Majeure Event

11.5.1 The Affected Party shall give notice to the other Party of any event of Force Majeure as soon as reasonably practicable, but not later than seven (7) days after the date on which such Party knew or should reasonably have known of the commencement of the event of Force Majeure. If an event of Force Majeure results in a breakdown of communications rendering it unreasonable to give notice within the applicable time limit specified herein, then the Party claiming Force Majeure shall give such notice as soon as reasonably practicable after reinstatement of communications, but not later than one (1) day after such reinstatement.

Provided that, such notice shall be a pre-condition to the Affected Party's entitlement to claim relief under this Agreement. Such notice shall include full particulars of the event of Force Majeure, its effects on the Party claiming relief and the remedial measures proposed. The Affected Party shall give the other Party regular reports on the progress of those remedial measures and such other information as the other Party may reasonably request about the Force Majeure.

11.5.2 The Affected Party shall give notice to the other Party of (i) the cessation of the relevant event of Force Majeure; and (ii) the cessation of the effects of such event of Force Majeure on the performance of its rights or obligations/ roles under this Agreement, as soon as practicable after becoming aware of each of these cessations.

11.6 Duty to perform and duty to mitigate

To the extent not prevented by a Force Majeure Event, the Affected Party shall continue to perform its obligations/ roles as provided in this Agreement. The Affected Party shall use its reasonable efforts to mitigate the effect of any event of Force Majeure as soon as practicable.

11.7 Available Relief for a Force Majeure Event

Subject to this Article 11,

- a) no Party shall be in breach of its obligations/ roles pursuant to this Agreement to the extent that the performance of its obligations/ roles was prevented, hindered or delayed due to a Force Majeure Event;

Transmission Service Agreement

- b) each Party shall be entitled to claim relief for a Force Majeure Event affecting its performance in relation to its obligations/ roles under Articles 3.3.4, 4.4.2 and 6.3.1 of this Agreement.
- c) For the avoidance of doubt, it is clarified that the computation of Availability of the Element(s) under outage due to Force Majeure Event, as per Article 11.3 affecting the TSP shall be as per **Appendix –IV to Central Electricity Regulatory Commission (Terms and Conditions of Tariff) Regulations, 2024** as on Bid Deadline. For the event(s) for which the Element(s) is/are deemed to be available as per **Appendix –IV to Central Electricity Regulatory Commission (Terms and Conditions of Tariff) Regulations, 2024**, then the Transmission Charges, as applicable to such Element(s), shall be payable as per Schedule 4, for the duration of such event(s).
- d) For so long as the TSP is claiming relief due to any Force Majeure Event under this Agreement, the Nodal Agency may, if it so desires, from time to time on one (1) day notice, inspect the Project and the TSP shall provide the Nodal Agency's personnel with access to the Project to carry out such inspections.
- e) For avoidance of doubt, the TSP acknowledges that for extension of Scheduled COD a period up to one hundred eighty (180) days due to Force Majeure event, no compensation on the grounds such as interest cost, incident expenditure, opportunity cost will be made to the TSP. However, if Scheduled COD is extended beyond a period of one hundred eighty (180) days due to Force Majeure event, the TSP will be allowed to recover the interest cost during construction corresponding to the period exceeding one hundred eighty (180) days by adjustment in the Transmission Charges in accordance with Schedule 9.

ARTICLE: 12

12 CHANGE IN LAW

12.1 Change in Law

12.1.1 Change in Law means the occurrence of any of the following after the Bid Deadline resulting into any additional recurring / non-recurring expenditure by the TSP or any savings of the TSP:

- the enactment, coming into effect, adoption, promulgation, amendment, modification or repeal (without re-enactment or consolidation) in India, of any Law, including rules and regulations framed pursuant to such Law, subject to the provisions under Article 12.1.2;
- a change in the interpretation or application of any Law by any Indian Governmental Instrumentality having the legal power to interpret or apply such Law, or any Competent Court of Law;
- the imposition of a requirement for obtaining any Consents, Clearances and Permits which was not required earlier;
- a change in the terms and conditions prescribed for obtaining any Consents, Clearances and Permits or the inclusion of any new terms or conditions for obtaining such Consents, Clearances and Permits;
- any change in the licensing regulations of the Commission, under which the Transmission License for the Project was granted if made applicable by such Commission to the TSP;
- change in wind zone; or
- any change in tax or introduction of any tax made applicable for providing Transmission Service by the TSP as per the terms of this Agreement.

12.1.2 Notwithstanding anything contained in this Agreement, Change in Law shall not cover any change:

- a) Taxes on corporate income; and
- b) Withholding tax on income or dividends distributed to the shareholders of the TSP.

12.2 Relief for Change in Law

12.2.1 During Construction Period, the impact of increase/decrease in the cost of the Project on the Transmission Charges shall be governed by the formula given in Schedule 9 of this Agreement.

12.2.2 During the Operation Period:

During the operation period, if as a result of Change in Law, the TSP suffers or is benefited from a change in costs or revenue, the aggregate financial effect of which

Transmission Service Agreement

exceeds 0.30% (zero point three percent) of the Annual Transmission Charges in aggregate for a Contract Year, the TSP may notify so to the Nodal Agency and propose amendments to this Agreement so as to place the TSP in the same financial position as it would have enjoyed had there been no such Change in Law resulting in change in costs or revenue as aforesaid.

- 12.2.3 For any claims made under Articles 12.2.1 and 12.2.2 above, the TSP shall provide to the Nodal Agency documentary proof of such increase / decrease in cost of the Project / revenue for establishing the impact of such Change in Law.

In cases where Change in Law results in decrease of cost and it comes to the notice of Nodal Agency that TSP has not informed Nodal Agency about such decrease in cost, Nodal Agency may initiate appropriate claim.

12.3 Notification of Change in Law:

- 12.3.1 If the TSP is affected by a Change in Law in accordance with Article 12.1 and wishes to claim relief for such Change in Law under this Article 12, it shall give notice to Nodal Agency of such Change in Law as soon as reasonably practicable after becoming aware of the same.
- 12.3.2 The TSP shall also be obliged to serve a notice to the Nodal Agency even when it is beneficially affected by a Change in Law.
- 12.3.3 Any notice served pursuant to Articles 12.3.1 and 12.3.2 shall provide, amongst other things, precise details of the Change in Law and its estimated impact on the TSP.

12.4 Payment on account of Change in Law

- 12.4.1 The payment for Change in Law shall be through a separate Bill. However, in case of any change in Monthly Transmission Charges by reason of Change in Law, as determined in accordance with this Agreement, the Bills to be raised by the Nodal Agency after such change in Transmission Charges shall appropriately reflect the changed Monthly Transmission Charges.

ARTICLE: 13

13 EVENTS OF DEFAULT AND TERMINATION

13.1 TSP's Event of Default

The occurrence and continuation of any of the following events shall constitute a TSP Event of Default, unless any such TSP Event of Default occurs as a result of any non-fulfilment of its obligations as prescribed under this Agreement by the Nodal Agency or a Force Majeure Event:

- a. After having taken up the construction of the Project, the abandonment by the TSP or the TSP's Contractors of the construction of the Project for a continuous period of two (2) months and such default is not rectified within thirty (30) days from the receipt of notice from the Nodal Agency in this regard;
- b. The failure to commission any Element of the Project by the date falling six (6) months after its Scheduled COD unless extended by Nodal Agency as per provisions of this Agreement;
- c. If the TSP:
 - i. assigns, mortgages or charges or purports to assign, mortgage or charge any of its assets or rights related to the Project in contravention of the provisions of this Agreement; or
 - ii. transfers or novates any of its obligations pursuant to this Agreement, in a manner contrary to the provisions of this Agreement;

Except where such transfer is in pursuance of a Law and

- i. it does not affect the ability of the transferee to perform, and such transferee has the financial and technical capability to perform, its obligations under this Agreement;
 - ii. is to a transferee who assumes such obligations under the Project and this Agreement remains effective with respect to the transferee;
- d. If:
 - i. The TSP becomes voluntarily or involuntarily the subject of any bankruptcy or insolvency or winding up proceedings and such proceedings remain uncontested for a period of thirty (30) days; or
 - ii. any winding up or bankruptcy or insolvency order is passed against the TSP; or
 - iii. the TSP goes into liquidation or dissolution or a receiver or any similar officer is appointed over all or substantially all of its assets or official liquidator is appointed to manage its affairs, pursuant to Law, Provided that a dissolution or liquidation of the TSP will not be a TSP's Event of Default, where such dissolution or liquidation of the TSP is for the purpose of a merger, consolidation or reorganization with the prior approval of the Commission as per the provisions of Central

Transmission Service Agreement

Electricity Regulatory Commission (Procedure, terms and Conditions for grant of Transmission License and other related matters) Regulations, 2006 or as amended from time to time; or

- e. Failure on the part of the TSP to comply with the provisions of Article 19.1 of this Agreement; or
- f. the TSP repudiates this Agreement and does not rectify such breach even within a period of thirty (30) days from a notice from the Nodal Agency in this regard; or
- g. after Commercial Operation Date of the Project, the TSP fails to achieve monthly Target Availability of [to be inserted by the BPC as applicable] [98% for AC system and 95% for HVDC system], for a period of six (6) consecutive months or within a non-consecutive period of six (6) months within any continuous aggregate period of eighteen(18) months except where the Availability is affected by Force Majeure Events as per Article 11; or
- h. any of the representations and warranties made by the TSP in Article 17 of this Agreement being found to be untrue or inaccurate. Further, in addition to the above, any of the undertakings submitted by the Selected Bidder at the time of submission of the Bid being found to be breached or inaccurate, including but not limited to undertakings from its Parent Company / Affiliates related to the minimum equity obligation; or
- i. the TSP fails to complete / fulfil all the activities / conditions within the specified period as per Article 3; or
- j. except for the reasons solely attributable to Nodal Agency, the TSP is in material breach of any of its obligations under this Agreement and such material breach is not rectified by the TSP within thirty (30) days of receipt of notice in this regard from the Nodal Agency; or
- k. the TSP fails to take the possession of the land required for location specific substations, switching stations or HVDC terminal or inverter stations and / or fails to pay the requisite price to the parties and / or any State Government authority from whom the land is acquired, within twelve (12) months from the Effective Date.

13.2 Termination Procedure for TSP Event of Default

- a. Upon the occurrence and continuance of any TSP's Event of Default under Article 13.1 the Nodal Agency may serve notice on the TSP, with a copy to the CEA and the Lenders' Representative, of their intention to terminate this Agreement (a "Nodal Agency's Preliminary Termination Notice"), which shall specify in reasonable detail, the circumstances giving rise to such Nodal Agency's Preliminary Termination Notice.
- b. Following the issue of a Nodal Agency's Preliminary Termination Notice, the Consultation Period shall apply and would be for the Parties to discuss as to

what steps shall be taken with a view to mitigate the consequences of the relevant Event of Default having regard to all the circumstances.

- c. During the Consultation Period, the Parties shall, save as otherwise provided in this Agreement, continue to perform their respective obligations/ roles under this Agreement, and the TSP shall not remove any material, equipment or any part of the Project, without prior consent of the Nodal Agency.

Following the expiry of the Consultation Period, unless the Parties shall have otherwise agreed to the contrary or the circumstances giving rise to Nodal Agency's Preliminary Termination Notice shall have ceased to exist or shall have been remedied, this Agreement may be terminated by the Nodal Agency by giving a Termination Notice to the TSP, in writing, of at least seven (7) days, with a copy to CEA and the Lenders' Representative in order to enable the Lenders to exercise right of substitution in accordance with Article 15.3 of this Agreement.

Further, the Nodal Agency may also initiate proceedings to blacklist the TSP & its Affiliates from participation in any RFP issued by BPCs for a period of 5 years.

13.3 Procedure for Nodal Agency's non-fulfilment of Role

- a. Upon the Nodal Agency not being able to fulfil its role under Article 4.2, the TSP may serve notice on the Nodal Agency, with a copy to CEA and the Lenders' Representative (a "TSP's Preliminary Notice"), which notice shall specify in reasonable detail the circumstances giving rise to such non-fulfilment of role by the Nodal Agency.
- b. Following the issue of a TSP's Preliminary Notice, the Consultation Period shall apply.
- c. The Consultation Period would be for the Parties to discuss as to what steps shall be taken with a view to mitigate the consequences of the relevant non-fulfilment of role by the Nodal Agency including giving time extension to TSP, having regard to all the circumstances.
- d. During the Consultation Period, both Parties shall, save as otherwise provided in this Agreement, continue to perform their respective obligations/ roles under this Agreement.

13.4 Termination due to Force Majeure

- 13.4.1 In case the Parties could not reach an agreement pursuant to Articles 3.3.4 and 4.4.2 of this Agreement and the Force Majeure Event or its effects continue to be present, the Nodal Agency shall have the right to cause termination of the Agreement. In case of such termination, the Contract Performance Guarantee shall be returned to the TSP as per the provisions of Article 6.5.1.

13.4.2 In case of termination of this Agreement, the TSP shall provide to the Nodal Agency the full names and addresses of its Contractors as well as complete designs, design drawings, manufacturing drawings, material specifications and technical information, as required by the Nodal Agency within thirty (30) days of Termination Notice.

13.5 Termination or amendment due to non-requirement of any Element or Project during construction

13.5.1 In case any Element or Project, which is under construction, is no longer required due to any reason whatsoever, the Nodal Agency may issue a notice to this effect to the TSP.

13.5.2 Nodal agency may also issue notice to the TSP seeking their response to the proposed termination/ amendment (as the case may be) of the Agreement. The Nodal Agency shall issue copy of such notice to Lenders. In the notice, Nodal Agency shall also include an assessment of the physical progress made by TSP in the Element/ Project (as the case may be) that is no longer required.

13.5.3 The TSP shall neither carry out further investment nor carry out any work on the Element/ Project (as the case may be) that is no longer required after delivery of the notice.

13.5.4 After taking into account the comments of the TSP, the Nodal Agency may terminate the Agreement or amend it if both Parties agree to the amendment.

13.6 Revocation of the Transmission License

13.6.1 The Commission may, as per the provisions of the Electricity Act, 2003, revoke the Transmission License of the ISTS Licensee. Further, in such a case, the Agreement shall be deemed to have been terminated.

13.7 Termination Payment

13.7.1 If Agreement is terminated on account of Force Majeure Events, non-requirement of any Element or Project during Construction, Nodal Agency's non-fulfilment of Role & TSP's Event of Default, the TSP shall be entitled for Termination Payment equivalent to valuation of Project Assets. Upon payment, the Nodal Agency shall take over the Project Assets.

ARTICLE: 14

14 LIABILITY AND INDEMNIFICATION

14.1 Indemnity

14.1.1 The TSP shall indemnify, defend and hold the Nodal Agency harmless against:

- (a) any and all third party claims, actions, suits or proceedings against the Nodal Agency for any loss of or damage to property of such third party, or death or injury to such third party, arising out of a breach by the TSP of any of its obligations under this Agreement, except to the extent that any such claim, action, suit or proceeding has arisen due to a negligent act or omission, breach of this Agreement or non-fulfilment of statutory duty on the part of Nodal Agency; and
- (b) any and all losses, damages, costs and expenses including legal costs, fines, penalties and interest actually suffered or incurred by the Nodal Agency from third party claims arising by reason of:
 - i. a breach by the TSP of any of its obligations under this Agreement, (provided that this Article 14 shall not apply to such breaches by the TSP, for which specific remedies have been provided for under this Agreement) except to the extent that any such losses, damages, costs and expenses including legal costs, fines, penalties and interest (together to constitute "Indemnifiable Losses") has arisen due to a negligent act or omission, breach of this Agreement or non-fulfilment of statutory duty on the part of the Nodal Agency, or
 - ii. any of the representations and warranties of the TSP under this Agreement being found to be inaccurate or untrue.

14.1.2 The Nodal Agency shall, in accordance with the Regulations framed by CERC in this regard, indemnify, defend and hold the TSP harmless against:

- (a) any and all third party claims, actions, suits or proceedings against the TSP, for any loss of or damage to property of such third party, or death or injury to such third party, arising out of any material breach by the Nodal Agency of any of their roles under this Agreement, except to the extent that any such claim, action, suit or proceeding has arisen due to a negligent act or omission, breach of this Agreement or breach of statutory duty on the part of the TSP, its Contractors, servants or agents; and
- (b) any and all losses, damages, costs and expenses including legal costs, fines, penalties and interest ('Indemnifiable Losses') actually suffered or incurred by the TSP from third party claims arising by reason of:

Transmission Service Agreement

- i. any material breach by the Nodal Agency of any of its roles under this Agreement (provided that, this Article 14 shall not apply to such breaches by the Nodal Agency, for which specific remedies have been provided for under this Agreement), except to the extent that any such Indemnifiable Losses have arisen due to a negligent act or omission, breach of this Agreement or breach of statutory duty on the part of the TSP, its Contractors, servants or agents or
- ii. any of the representations and warranties of the Nodal Agency under this Agreement being found to be inaccurate or untrue.

14.2 Patent Indemnity:

14.2.1

- (a) The TSP shall, subject to the Nodal Agency's compliance with Article 14.2.1 (b), indemnify and hold harmless the Nodal Agency and its employees and officers from and against any and all suits, actions or administrative proceedings, claims, demands, losses, damages, costs, and expenses of whatsoever nature, including attorney's fees and expenses, which the Nodal Agency may suffer as a result of any infringement or alleged infringement of any patent, utility model, registered design, trademark, copyright or other intellectual property right registered or otherwise existing at the date of the Agreement by reason of the setting up of the Project by the TSP.

Such indemnity shall not cover any use of the Project or any part thereof other than for the purpose indicated by or to be reasonably inferred from the Agreement, any infringement resulting from the misuse of the Project or any part thereof, or any products produced in association or combination with any other equipment, plant or materials not supplied by the TSP, pursuant to the Agreement.

- (b) If any proceedings are brought or any claim is made against the Nodal Agency arising out of the matters referred to in Article 14.2.1(a), the Nodal Agency shall promptly give the TSP a notice thereof, and the TSP shall at its own expense take necessary steps and attend such proceedings or claim and any negotiations for the settlement of any such proceedings or claim. The TSP shall promptly notify the Nodal Agency of all actions taken in such proceedings or claims.
- (c) If the TSP fails to notify the Nodal Agency within twenty-eight (28) days after receipt of such notice from the Nodal Agency under Article 14.2.1(b) above, that it intends to attend any such proceedings or claim, then the Nodal Agency shall be free to attend the same on their own behalf at the cost of the TSP. Unless the TSP has so failed to notify the Nodal Agency within the twenty eight (28) days period, the Nodal Agency shall make no admission that may be prejudicial to the defence

of any such proceedings or claims.

- (d) The Nodal Agency shall, at the TSP's request, afford all available assistance to the TSP in attending to such proceedings or claim, and shall be reimbursed by the TSP for all reasonable expenses incurred in so doing.

14.2.2

- (a) The Nodal Agency, in accordance with the Regulations framed by CERC in this regard, subject to the TSP's compliance with Article 14.2.2(b) shall indemnify and hold harmless the TSP and its employees, officers from and against any and all suits, actions or administrative proceedings, claims, demands, losses, damages, costs and expenses of whatsoever nature, including attorney's fees and expenses, which the TSP may suffer as a result of any infringement or alleged infringement of any patent, utility model, registered design, trademark, copyright or other intellectual property right registered or otherwise existing at the date of the Agreement by reason of the setting up of the Project by the TSP.
- (b) If any proceedings are brought or any claim is made against the TSP arising out of the matters referred to in Article 14.2.2 (a) the TSP shall promptly give the Nodal Agency a notice thereof, and the Nodal Agency shall at its own expense take necessary steps and attend such proceedings or claim and any negotiations for the settlement of any such proceedings or claim. The Nodal Agency shall promptly notify the TSP of all actions taken in such proceedings or claims.
- (c) If the Nodal Agency fails to notify the TSP within twenty-eight (28) days after receipt of such notice from the TSP under Article 14.2.2(b) above, that it intends to attend any such proceedings or claim, then the TSP shall be free to attend the same on its own behalf at the cost of the Nodal Agency. Unless the Nodal Agency has so failed to notify the TSP within the twenty (28) days period, the TSP shall make no admission that may be prejudicial to the defence of any such proceedings or claim.
- (d) The TSP shall, at the Nodal Agency request, afford all available assistance to the Nodal Agency in attending to such proceedings or claim, and shall be reimbursed by the Nodal Agency for all reasonable expenses incurred in so doing.

14.3 Monetary Limitation of liability

- 14.3.1 A Party ("Indemnifying Party") shall be liable to indemnify the other Party ("Indemnified Party") under this Article 14 for any indemnity claims made in a Contract Year only up to an amount of Rupees **31.83 Crore** (Rs. Thirty One Crore and Eighty Three Lakh).

14.4 Procedure for claiming indemnity

14.4.1 Where the Indemnified Party is entitled to indemnification from the Indemnifying Party pursuant to Articles 14.1 or 14.2 the Indemnified Party shall promptly notify the Indemnifying Party of such claim, proceeding, action or suit referred to in Articles 14.1 or 14.2 in respect of which it is entitled to be indemnified. Such notice shall be given as soon as reasonably practicable after the Indemnified Party becomes aware of such claim, proceeding, action or suit. The Indemnifying Party shall be liable to settle the indemnification claim within thirty (30) days of receipt of the above notice.

Provided however that, if:

- i. the Parties choose to contest, defend or litigate such claim, action, suit or proceedings in accordance with Article 14.4.3 below; and
- ii. the claim amount is not required to be paid/deposited to such third party pending the resolution of the Dispute,

the Indemnifying Party shall become liable to pay the claim amount to the Indemnified Party or to the third party, as the case may be, promptly following the resolution of the Dispute, if such Dispute is not settled in favour of the Indemnified Party.

14.4.2 The Indemnified Party may contest, defend and litigate a claim, action, suit or proceeding for which it is entitled to be indemnified under Articles 14.1 or 14.2 and the Indemnifying Party shall reimburse to the Indemnified Party all reasonable costs and expenses incurred by the Indemnified Party. However, such Indemnified Party shall not settle or compromise such claim, action, suit or proceedings without first getting the consent of the Indemnifying Party, which consent shall not be unreasonably withheld or delayed.

14.4.3 An Indemnifying Party may, at its own expense, assume control of the defence of any proceedings brought against the Indemnified Party if it acknowledges its obligation to indemnify such Indemnified Party, gives such Indemnified Party prompt notice of its intention to assume control of the defence, and employs an independent legal counsel at its own cost that is reasonably satisfactory to the Indemnified Party.

14.5 Limitation on Liability

14.5.1 Except as expressly provided in this Agreement, neither the TSP nor the Nodal Agency nor their respective officers, directors, agents, employees or Affiliates (including, officers, directors, agents or employees of such Affiliates), shall be liable or responsible to the other Party or its Affiliates including its officers, directors, agents, employees, successors, insurers or permitted assigns for incidental, indirect or consequential, punitive or exemplary damages, connected with or resulting from performance or non-performance of this Agreement, or anything done in connection herewith,

Transmission Service Agreement

including claims in the nature of lost revenues, income or profits (other than payments expressly required and properly due under this Agreement), any increased expense of, reduction in or loss of transmission capacity or equipment used therefore, irrespective of whether such claims are based upon breach of warranty, tort (including negligence, whether of the Nodal Agency, the TSP or others), strict liability, contract, breach of statutory duty, operation of law or otherwise.

14.5.2 The Nodal Agency shall have no recourse against any officer, director or shareholder of the TSP or any Affiliate of the TSP or any of its officers, directors or shareholders for such claims excluded under this Article. The TSP shall also have no recourse against any officer, director or shareholder of the Nodal Agency, or any Affiliate of the Nodal Agency or any of its officers, directors or shareholders for such claims excluded under this Article.

14.6 Duty to Mitigate

The party entitled to the benefit of an indemnity under this Article 14 shall take all reasonable measures to mitigate any loss or damage which has occurred. If the Party fails to take such measures, the other Party's liabilities shall be correspondingly reduced.

ARTICLE: 15

15 ASSIGNMENTS AND CHARGES

15.1 Assignments:

15.1.1 This Agreement shall be binding upon, and inure to the benefit of the Parties and their respective successors and permitted assigns. This Agreement shall not be assigned by any Party, except as provided in Article 15.3.

15.2 Permitted Charges:

15.2.1 Neither Party shall create or permit to subsist any encumbrance over all or any of its rights and benefits under this Agreement.

15.2.2 However, the TSP may create any encumbrance over all or part of the receivables, or the Project Assets of the Project in favour of the Lenders or the Lenders' Representative on their behalf, as security for amounts payable under the Financing Agreements and any other amounts agreed by the Parties.

Provided that:

- i. the Lenders or the Lenders' Representative on their behalf shall have entered into the Financing Agreements and agreed in writing to the provisions of this Agreement; and
- ii. any encumbrance granted by the TSP in accordance with this Article 15.2.2 shall contain provisions pursuant to which the Lenders or the Lender's Representative on their behalf agrees unconditionally with the TSP to release from such encumbrances upon payment by the TSP to the Lenders of all amounts due under the Financing Agreements.

15.2.3 Article 15.2.1 does not apply to:

- a. liens arising by operation of law (or by an agreement evidencing the same) in the ordinary course of the TSP developing and operating the Project;
- b. pledges of goods, the related documents of title and / or other related documents, arising or created in the ordinary course of the TSP developing and operating the Project; or
- c. security arising out of retention of title provisions in relation to goods acquired in the ordinary course of the TSP developing and operating the Project.

15.3 Substitution Rights of the Lenders

15.3.1 The TSP would need to operate and maintain the Project under the provisions of this

Transmission Service Agreement

Agreement and cannot assign the Transmission License or transfer the Project or part thereof to any person by sale, lease, exchange or otherwise, without the prior approval of the Nodal Agency.

- 15.3.2 However, in the case of default by the TSP in debt repayments or in the case of default by the TSP as per Article 13 of this Agreement during the debt repayments, the Commission may, on an application from the Lenders, assign the Transmission License to the nominee of the Lenders subject to the fulfilment of the qualification requirements and provisions of the Central Electricity Regulatory Commission (Procedure, terms and Conditions for grant of Transmission License and other related matters) Regulations, 2006 and as amended from time to time.

ARTICLE: 16

16 GOVERNING LAW AND DISPUTE RESOLUTION

16.1 Governing Law:

This Agreement shall be governed by and construed in accordance with the Laws of India. Any legal proceedings in respect of any matters, claims or disputes under this Agreement shall be under the jurisdiction of appropriate courts in Delhi.

16.2 Amicable Settlement:

16.2.1 Either Party is entitled to raise any claim, dispute or difference of whatever nature arising under, out of or in connection with this Agreement, including its existence or validity or termination or whether during the execution of the Project or after its completion and whether prior to or after the abandonment of the Project or termination or breach of the Agreement by giving a written notice to the other Party, which shall contain:

- (i) a description of the Dispute;
- (ii) the grounds for such Dispute; and
- (iii) all written material in support of its claim.

16.2.2 The other Party shall, within thirty (30) days of issue of notice issued under Article 16.2.1, furnish:

- (i) counter-claim and defences, if any, regarding the Dispute; and
- (ii) all written material in support of its defences and counter-claim.

16.2.3 Within thirty (30) days of issue of notice by the Party pursuant to Article 16.2.1, if the other Party does not furnish any counter claim or defense under Article 16.2.2, or thirty (30) days from the date of furnishing counter claims or defence by the other Party, both the Parties to the Dispute shall meet to settle such Dispute amicably. If the Parties fail to resolve the Dispute amicably within thirty (30) days from the later of the dates mentioned in this Article 16.2.3, the Dispute shall be referred for dispute resolution in accordance with Article 16.3.

16.3 Dispute Resolution:

All Disputes shall be adjudicated by the Commission.

16.4 Parties to Perform Obligations:

Notwithstanding the existence of any Dispute and difference referred to the Commission as provided in Article 16.3 and save as the Commission may otherwise direct by a final or interim order, the Parties hereto shall continue to perform their respective obligations/ roles (which are not in dispute) under this Agreement.

ARTICLE: 17

17 REPRESENTATION AND WARRANTIES

17.1 Representation and warranties of the Nodal Agency

17.1.1 The Nodal Agency hereby represents and warrants to and agrees with the TSP as follows and acknowledges and confirms that the TSP is relying on such representations and warranties in connection with the transactions described in this Agreement:

- a. It has all requisite powers and authority to execute and consummate this Agreement;
- b. This Agreement is enforceable against the Nodal Agency in accordance with its terms;
- c. The consummation of the transactions contemplated by this Agreement on the part of Nodal Agency will not violate any provision of nor constitute a default under, nor give rise to a power to cancel any charter, mortgage, deed of trust or lien, lease, agreement, license, permit, evidence of indebtedness, restriction, or other contract to which the Nodal Agency is a Party or to which the Nodal Agency is bound, which violation, default or power has not been waived;

17.2 Representation and Warranties of the TSP:

17.2.1 The TSP hereby represents and warrants to and agrees with the Nodal Agency as follows and acknowledges and confirms that the Nodal Agency is relying on such representations and warranties in connection with the transactions described in this Agreement:

- a. It has all requisite powers and has been duly authorized to execute and consummate this Agreement;
- b. This Agreement is enforceable against it, in accordance with its terms;
- c. The consummation of the transactions contemplated by this Agreement on the part of the TSP will not violate any provision of nor constitute a default under, nor give rise to a power to cancel any charter, mortgage, deed of trust or lien, lease, agreement, license, permit, evidence of indebtedness, restriction, or other contract to which the TSP is a Party or to which the TSP is bound which violation, default or power has not been waived;
- d. The TSP is not insolvent and no insolvency proceedings have been instituted, nor threatened or pending by or against the TSP;

Transmission Service Agreement

- e. There are no actions, suits, claims, proceedings or investigations pending or, to the best of the TSP's knowledge, threatened in writing against the TSP at law, in equity, or otherwise, and whether civil or criminal in nature, before or by, any court, commission, arbitrator or governmental agency or authority, and there are no outstanding judgments, decrees or orders of any such courts, commission, arbitrator or governmental agencies or authorities, which materially adversely affect its ability to execute the Project or to comply with its obligations under this Agreement.

17.2.2 The TSP makes all the representations and warranties above to be valid as on the Effective Date of this Agreement.

ARTICLE: 18

18 INDEPENDENT ENGINEER

18.1 Appointment of Independent Engineer

The Nodal Agency shall appoint an agency/ company as Independent Engineer as per framework provided in the Guidelines for Encouraging Competition in Development of Transmission Projects for selection of Independent Engineer.

18.2 Roles and functions of Independent Engineer

The role and functions of the Independent Engineer shall include the following:

- a. Progress Monitoring as required under this Agreement;
- b. Ensuring Quality as required under this Agreement;
- c. determining, as required under the Agreement, the costs of any works or services and/or their reasonableness during construction phase;
- d. determining, as required under the Agreement, the period or any extension thereof, for performing any duty or obligation during construction phase;
- e. determining, as required under the Agreement, the valuation of the Project Assets.
- f. Assisting the Parties in resolution of Disputes and
- g. Undertaking all other duties and functions in accordance with the Agreement.

18.3 Remuneration of Independent Engineer

The fee and charges of the Independent Engineer shall be paid by the Nodal Agency as per terms & conditions of appointment.

18.4 Termination of appointment

18.4.1 The Nodal Agency may, in its discretion, terminate the appointment of the Independent Engineer at any time, but only after appointment of another Independent Engineer.

18.4.2 If the TSP has reason to believe that the Independent Engineer is not discharging its duties and functions in a fair, efficient and diligent manner, it may make a written representation to the Nodal Agency and seek termination of the appointment of the Independent Engineer. Upon receipt of such representation, the Nodal Agency shall hold a tripartite meeting with the TSP and Independent Engineer for an amicable

resolution, and the decision of Nodal agency is final. In the event that the appointment of the Independent Engineer is terminated hereunder, the Nodal Agency shall appoint forthwith another Independent Engineer.

18.5 Authorised signatories

The Nodal Agency shall require the Independent Engineer to designate and notify to the Nodal Agency up to 2 (two) persons employed in its firm to sign for and on behalf of the Independent Engineer, and any communication or document required to be signed by the Independent Engineer shall be valid and effective only if signed by any of the designated persons; provided that the Independent Engineer may, by notice in writing, substitute any of the designated persons by any of its employees.

ARTICLE: 19

19 MISCELLANEOUS PROVISIONS

19.1 Equity Lock-in Commitment:

19.1.1 The aggregate equity share holding of the Selected Bidder in the issued and paid up equity share capital of KPS III HVDC TRANSMISSION LIMITED shall not be less than Fifty one percent (51%) up to a period of one (1) year after COD of the Project.

Provided that, in case the Lead Member or Bidding Company is holding equity through Affiliate/s, Ultimate Parent Company or Parent Company, such restriction as specified above shall apply to such entities.

Provided further, that in case the Selected Bidder is a Bidding Consortium, the Lead Member shall continue to hold equity of at least twenty six percent (26%) upto a period of one (1) year after COD of the Project and any Member of such Bidding Consortium shall be allowed to divest its equity as long as the other remaining Members (which shall always include the Lead Member) hold the minimum equity specified above.

19.1.2 If equity is held by the Affiliates, Parent Company or Ultimate Parent Company of the Selected Bidder, then, subject to the second proviso to Article 19.1.1, such Affiliate, Parent Company or Ultimate Parent Company shall be eligible to transfer its shareholding in KPS III HVDC TRANSMISSION LIMITED to another Affiliate or to the Parent Company / Ultimate Parent Company of the Selected Bidder. If any such shareholding entity, qualifying as an Affiliate / Parent Company / Ultimate Parent Company, is likely to cease to meet the criteria to qualify as an Affiliate / Parent Company / Ultimate Parent Company, the shares held by such entity shall be transferred to another Affiliate / Parent Company / Ultimate Parent Company of the Selected Bidder.

19.1.3 Subject to Article 19.1.1, all transfer(s) of shareholding of KPS III HVDC TRANSMISSION LIMITED by any of the entities referred to in Article 19.1.1 and 19.1.2 above, shall be after prior written intimation to the Nodal Agency.

19.1.4 For computation of effective Equity holding, the Equity holding of the Selected Bidder or its Ultimate Parent Company in such Affiliate(s) or Parent Company and the equity holding of such Affiliate(s) or Ultimate Parent Company in KPS III HVDC TRANSMISSION LIMITED shall be computed in accordance with the example given below:

If the Parent Company or the Ultimate Parent Company of the Selected Bidder A directly holds thirty percent (30%) of the equity in KPS III HVDC TRANSMISSION LIMITED, then holding of Selected Bidder A in KPS III HVDC TRANSMISSION LIMITED

shall be thirty percent (30%);

If Selected Bidder A holds thirty percent (30%) equity of the Affiliate and the Affiliate holds fifty percent (50%) equity in KPS III HVDC TRANSMISSION LIMITED, then, for the purposes of ascertaining the minimum equity/equity lock-in requirements specified above, the effective holding of Bidder A in KPS III HVDC TRANSMISSION LIMITED shall be fifteen percent (15%), (i.e., 30% x 50%)

19.1.5 The provisions as contained in this Article 19.1 shall override the terms of the consortium agreement submitted as part of the Bid.

19.1.6 The TSP shall be responsible to report to Nodal Agency, within thirty (30) days from the occurrence of any event that would result in any change in its equity holding structure from that which existed as on the date of signing of the Share Purchase Agreement. In such cases, the Nodal Agency would reserve the right to ascertain the equity holding structure and to call for all such required documents / information / clarifications as may be required.

19.2 Commitment of maintaining Qualification Requirement

19.2.1 The Selected Bidder will be required to continue to maintain compliance with the Qualification Requirements, as stipulated in RFP Document, till the COD of the Project. Where the Technically Evaluated Entity and/or the Financially Evaluated Entity is not the Bidding Company or a Member in a Bidding Consortium, as the case may be, the Bidding Company or Member shall continue to be an Affiliate of the Technically Evaluated Entity and/or Financially Evaluated Entity till the COD of the Project.

19.2.2 Failure to comply with the aforesaid provisions shall be dealt in the same manner as TSP's Event of Default as under Article 13 of this Agreement.

19.3 Language:

19.3.1 All agreements, correspondence and communications between the Parties relating to this Agreement and all other documentation to be prepared and supplied under the Agreement shall be written in English, and the Agreement shall be construed and interpreted in accordance with English language.

19.3.2 If any of the agreements, correspondence, communications or documents are prepared in any language other than English, the English translation of such agreements, correspondence, communications or documents shall prevail in matters of interpretation.

19.4 Affirmation

The TSP and the Nodal Agency, each affirm that:

- a) neither it nor its respective directors, employees, or agents has paid or undertaken to pay or shall in the future pay any unlawful commission, bribe, pay-off or kick-back; and
- b) it has not in any other manner paid any sums, whether in Indian currency or foreign currency and whether in India or abroad to the other Party to procure this Agreement, and the TSP and the Nodal Agency hereby undertake not to engage in any similar acts during the Term of Agreement.

19.5 Severability

The invalidity or enforceability, for any reason, of any part of this Agreement shall not prejudice or affect the validity or enforceability of the remainder of this Agreement, unless the part held invalid or unenforceable is fundamental to this Agreement.

19.6 Counterparts

This Agreement may be executed in one or more counterparts, each of which shall be deemed an original and all of which collectively shall be deemed one and the same Agreement.

19.7 Breach of Obligations/ Roles

The Parties acknowledge that a breach of any of the obligations/ roles contained herein would result in injuries. The Parties further acknowledge that the amount of the liquidated damages or the method of calculating the liquidated damages specified in this Agreement is a genuine and reasonable pre-estimate of the damages that may be suffered by the non-defaulting Party in each case specified under this Agreement.

19.8 Restriction of Shareholders / Owners Liability

19.8.1 Parties expressly agree and acknowledge that none of the shareholders of the Parties hereto shall be liable to the other Parties for any of the contractual obligations of the concerned Party under this Agreement.

19.8.2 Further, the financial liabilities of the shareholder(s) of each Party to this Agreement shall be restricted to the extent provided in the Indian Companies Act, 1956 / Companies Act, 2013 (as the case may be).

19.9 Taxes and Duties:

19.9.1 The TSP shall bear and promptly pay all statutory taxes, duties, levies and cess, assessed/levied on the TSP, its Contractors or their employees that are required to be paid by the TSP as per the Law in relation to the execution of the Project and for

providing Transmission Service as per the terms of this Agreement.

19.9.2 The Nodal Agency shall be indemnified and held harmless by the TSP against any claims that may be made against the Nodal Agency in relation to the matters set out in Article 19.9.1.

19.9.3 The Nodal Agency shall not be liable for any payment of, taxes, duties, levies, cess whatsoever for discharging any obligation of the TSP by the Nodal Agency on behalf of TSP or its personnel, provided the TSP has consented in writing to the Nodal Agency for such work, for which consent shall not be unreasonably withheld.

19.10 No Consequential or Indirect Losses

The liability of the TSP shall be limited to that explicitly provided in this Agreement.

Provided that, notwithstanding anything contained in this Agreement, under no event shall the Nodal Agency or the TSP claim from one another any indirect or consequential losses or damages.

19.11 Discretion:

Except where this Agreement expressly requires a Party to act fairly or reasonably, a Party may exercise any discretion given to it under this Agreement in any way it deems fit.

19.12 Confidentiality

19.12.1 The Parties undertake to hold in confidence this Agreement and RFP Project Documents and not to disclose the terms and conditions of the transaction contemplated hereby to third parties, except:

- a) to their professional advisors;
- b) to their officers, contractors, employees, agents or representatives, financiers, who need to have access to such information for the proper performance of their activities; or
- c) disclosures required under Law,

without the prior written consent of the other Parties.

Provided that, the TSP agrees and acknowledges that the Nodal Agency, may, at any time, disclose the terms and conditions of the Agreement and the RFP Project Documents to any person, to the extent stipulated under the Law and the Competitive Bidding Guidelines.

19.13 Order of priority in application:

Save as provided in Article 2.5, in case of inconsistencies between the terms and conditions stipulated in Transmission License issued by the Commission to the TSP, agreement(s) executed between the Parties, applicable Law including rules and regulations framed thereunder, the order of priority as between them shall be the order in which they are placed below:

- terms and conditions of Transmission License;
- applicable Law, rules and regulations framed thereunder;
- this Agreement;
- Agreement(s), if any, under Sharing Regulations.

19.14 Independent Entity:

19.14.1 The TSP shall be an independent entity performing its obligations pursuant to the Agreement.

19.14.2 Subject to the provisions of the Agreement, the TSP shall be solely responsible for the manner in which its obligations under this Agreement are to be performed. All employees and representatives of the TSP or Contractors engaged by the TSP in connection with the performance of the Agreement shall be under the complete control of the TSP and shall not be deemed to be employees, representatives, Contractors of the Nodal Agency and nothing contained in the Agreement or in any agreement or contract awarded by the TSP shall be construed to create any contractual relationship between any such employees, representatives or Contractors and the Nodal Agency.

19.15 Amendments:

19.15.1 This Agreement may only be amended or supplemented by a written agreement between the Parties.

19.16 Waiver:

19.16.1 No waiver by either Party of any default or breach by the other Party in the performance of any of the provisions of this Agreement shall be effective unless in writing duly executed by an authorised representative of such Party.

19.16.2 Neither the failure by either Party to insist on any occasion upon the performance of the terms, conditions and provisions of this Agreement nor time or other indulgence granted by one Party to the other Parties shall act as a waiver of such breach or acceptance of any variation or the relinquishment of any such right or any

other right under this Agreement, which shall remain in full force and effect.

19.17 Relationship of the Parties:

This Agreement shall not be interpreted or construed to create an association, joint venture, or partnership or agency or any such other relationship between the Parties or to impose any partnership obligation or liability upon either Party and neither Party shall have any right, power or authority to enter into any agreement or undertaking for, or act on behalf of, or to act as or be an agent or representative of, or to otherwise bind, the other Party.

19.18 Entirety:

19.18.1 This Agreement along with its sections, schedules and appendices is intended by the Parties as the final expression of their agreement and is intended also as a complete and exclusive statement of the terms of their agreement.

19.18.2 Except as provided in this Agreement, all prior written or oral understandings, offers or other communications of every kind pertaining to this Agreement or the provision of Transmission Service under this Agreement to the Nodal Agency by the TSP shall stand superseded and abrogated.

19.19 Notices:

19.19.1 All notices or other communications which are required to be given under this Agreement shall be in writing and in the English language

19.19.2 If to the TSP, all notices or communications must be delivered personally or by registered post or facsimile or any other mode duly acknowledged to the addressee below:

Address :
Attention :
Email :
Fax. No. :
Telephone No. :

19.19.3 If to the Nodal Agency, all notices or communications must be delivered personally or by registered post or facsimile or any other mode duly acknowledged to the addresses below:

(i) Central Transmission Utility of India Limited (Nodal Agency)

Address :
Attention :
Email :
Fax. No. :

Telephone No. :

- 19.19.4 All notices or communications given by facsimile shall be confirmed by sending a copy of the same via post office in an envelope properly addressed to the appropriate Party for delivery by registered mail. All notices shall be deemed validly delivered upon receipt evidenced by an acknowledgement of the recipient, unless the Party delivering the notice can prove in case of delivery through the registered post that the recipient refused to acknowledge the receipt of the notice despite efforts of the postal authorities.
- 19.19.5 Any Party may by notice of at least fifteen (15) days to the other Party change the address and/or addresses to which such notices and communications to it are to be delivered or mailed.

19.20 Fraudulent and Corrupt Practices

- 19.20.1 The TSP and its respective officers, employees, agents and advisers shall observe the highest standard of ethics during the subsistence of this Agreement. Notwithstanding anything to the contrary contained in the Agreement, the Nodal Agency may terminate the Agreement without being liable in any manner whatsoever to the TSP, if it determines that the TSP has, directly or indirectly or through an agent, engaged in corrupt practice, fraudulent practice, coercive practice, undesirable practice or restrictive practice in the Bid process. In such an event, the Nodal Agency shall forfeit the Contract Performance Guarantee of the TSP, without prejudice to any other right or remedy that may be available to the Nodal Agency hereunder or subsistence otherwise.
- 19.20.2 Without prejudice to the rights of the Nodal Agency under Clause 19.20.1 hereinabove and the rights and remedies which the Nodal Agency may have under this Agreement, if a TSP is found by the Nodal Agency to have directly or indirectly or through an agent, engaged or indulged in any corrupt practice, fraudulent practice, coercive practice, undesirable practice or restrictive practice during the Bid process, or after the issue of Letter of Intent (hereinafter referred to as Lol) or after the execution of the agreement(s) required under Sharing Regulations, the Nodal Agency may terminate the Agreement without being liable in any manner whatsoever to the TSP. Further, the TSP & its Affiliates shall not be eligible to participate in any tender or RFP issued by any BPC for an indefinite period from the date such TSP is found by the Nodal Agency to have directly or indirectly or through an agent, engaged or indulged in any corrupt practice, fraudulent practice, coercive practice, undesirable practice or restrictive practices, as the case may be.
- 19.20.3 For the purposes of this Clause 19.20, the following terms shall have the meaning hereinafter respectively assigned to them:

(a) **“corrupt practice”** means (i) the offering, giving, receiving, or soliciting, directly or indirectly, of anything of value to influence the actions of any person connected with the Bid process (for avoidance of doubt, offering of employment to or employing or engaging in any manner whatsoever, directly or indirectly, any official of the BPC who is or has been associated or dealt in any manner, directly or indirectly with the Bid process or the Lol or has dealt with matters concerning the RFP Project Documents or arising there from, before or after the execution thereof, at any time prior to the expiry of one year from the date such official resigns or retires from or otherwise ceases to be in the service of the BPC, shall be deemed to constitute influencing the actions of a person connected with the Bid Process); or (ii) engaging in any manner whatsoever, whether during the Bid Process or after the issue of the Lol or after the execution of the RFP Project Documents, as the case may be, any person in respect of any matter relating to the Project or the Lol or the RFP Project Documents, who at any time has been or is a legal, financial or technical adviser of the BPC in relation to any matter concerning the Project;

(b) **“fraudulent practice”** means a misrepresentation or omission of facts or suppression of facts or disclosure of incomplete facts, in order to influence the Bid process;

(c) **“coercive practice”** means impairing or harming, or threatening to impair or harm, directly or indirectly, any person or property to influence any person’s participation or action in the Bid process;

(d) **“undesirable practice”** means (i) establishing contact with any person connected with or employed or engaged by the BPC with the objective of canvassing, lobbying or in any manner influencing or attempting to influence the Bid process; or (ii) having a Conflict of Interest; and

(e) **“restrictive practice”** means forming a cartel or arriving at any understanding or arrangement among Bidders with the objective of restricting or manipulating a full and fair competition in the Bid process;

19.21 Compliance with Law:

Despite anything contained in this Agreement but without prejudice to Article 12, if any provision of this Agreement shall be in deviation or inconsistent with or repugnant to the provisions contained in the Electricity Act, 2003, or any rules and regulations made there under, such provision shall be deemed to be amended to the extent required to bring it into compliance with the aforesaid relevant provisions as amended from time to time.

IN WITNESS WHEREOF, THE PARTIES HAVE CAUSED THIS AGREEMENT TO BE EXECUTED BY THEIR DULY AUTHORISED REPRESENTATIVES AS OF THE DATE AND PLACE SET FORTH ABOVE.

Transmission Service Agreement

1. For and on behalf of TSP

.....

[Signature, Name, Designation and Address]

2. For and on behalf of **Central Transmission Utility of India Limited (Nodal Agency)**

.....

[Signature, Name, Designation and Address]

WITNESSES:

1. For and on behalf of

: **BPC**

.....
[Signature]

.....
[Insert, Name, Designation and Address of the Witness]

2. For and on behalf of

: **Nodal Agency**

.....
[Signature]

.....
[Insert Name, Designation and Address of the Witness]

Transmission Service Agreement

SCHEDULES

Schedule: 1**Project Description and Scope of Project****Annexure – A****i) Description of the Transmission Scheme:**

Government of India has set a target for establishing 500 GW capacity from non-fossil energy sources by 2030. In this direction, in December 2020, Hon'ble Prime Minister laid the foundation stone of the world's largest renewable energy park in Gujarat's Kutch. This 30 GW capacity hybrid renewable energy park is being built along the Indo-Pak border at Khavda using both wind and solar energy and is expected to play a major role in fulfilling India's vision of generating 500 GW of non-fossil generation capacity by 2030.

Out of 30 GW, 15 GW RE capacity is expected to come up by 2024-25 and balance by 2026-27 timeframe and beyond. Transmission system for evacuation of up to 22 GW power from Khavda RE Park is already under implementation/bidding in 4 phases as per details below:

Phase	RE Capacity (GW)	Status of Transmission System
I	3	<u>Under Implementation:</u> <ul style="list-style-type: none"> • KPS1 S/s and KPS1 – Bhuj 765 kV D/C line: Awarded to Adani Transmission Ltd. (Commissioned). • KPS2 S/s: Awarded to POWERGRID with SCOD of Dec'24. • KPS1 – KPS2 765 kV D/C line: Awarded to Megha Engg with SCOD of Jan'25.
II	5	<u>Under Implementation:</u> <ul style="list-style-type: none"> • KPS3 S/s and KPS3 – KPS2 765 kV D/C line: Awarded to POWERGRID with SCOD of Dec'24. • Khavda Ph-II Part A - Awarded to Adani Transmission Ltd. with Expected SCOD of March'25. • Khavda Ph-II Parts B and C – Awarded to POWERGRID with Expected SCOD of March'25. • Khavda Ph-II Part D – Awarded to TPGL(RTM) with Expected SCOD of March'25.
III	7	<u>Under Implementation:</u> <u>Khavda-Ph-III-Part A-Awarded to Adani</u> <u>Khavda-Ph-III-Part-B -Awarded to POWERGRID</u> <ul style="list-style-type: none"> • <u>Expected SCOD: Dec'25</u>
IV	7	<u>Under Bidding:</u> <ul style="list-style-type: none"> • Agreed in 14th NCT –and expected SCOD is Jun'26

Transmission Service Agreement

The Phase-V scheme has been planned to enable evacuation of an additional 8 GW RE power from Khavda RE park.

The subject scheme (under Part C) includes establishment of KPS3 (HVDC) S/s through KPS3 – KPS3 (HVDC) 400 kV 2xD/C line and establishment of 2500 MW, ± 500 kV HVDC [VSC] terminal station (2x1250 MW) at KPS3(HVDC) and South Olpad along with ± 500 kV HVDC Bipole line with DMR between KPS3 (HVDC) and South Olpad (HVDC).

The subject Transmission system was deliberated and approved in the 14th NCT meeting held on 09.06.2023. The Ministry of Power vide Gazette notification dated 29.08.2023 (Copy of Gazette attached) has appointed PFCCL as BPC for implementation of the subject transmission scheme through TBCB route.

ii) Detailed Scope of Work

Transmission System for Evacuation of Power from potential renewable energy zone in Khavda area of Gujarat under Phase-V (8GW): Part C

Sl. No.	Scope	Capacity/ Route length
1.	Establishment of 2500 MW, ± 500 kV KPS3 (HVDC) [VSC] terminal station (2x1250 MW) at a suitable location near KPS3 substation with associated interconnections with 400 kV HVAC Switchyard*	2500 MW, ± 500 kV KPS3 (HVDC) [VSC] Terminal station
2.	Establishment of 2500 MW, ± 500 kV South Olpad (HVDC) [VSC] terminal station (2x1250 MW) along with associated interconnections with 400 kV HVAC Switchyard of South Olpad S/s*	2500 MW, ± 500 kV South Olpad (HVDC) [VSC] terminal station
3.	Establishment of KPS3 (HVDC) S/s along with 2x125 MVAR, 420 kV bus reactors along with associated interconnections with HVDC Switchyard*. The 400 kV bus shall be established in 2 sections through 1 set of 400 kV bus sectionaliser to be kept normally OPEN. 400/33 kV, 2x50 MVA transformers for exclusively supplying auxiliary power to HVDC terminal. Future Provisions at KPS3 (HVDC) S/s Space for:	<ul style="list-style-type: none"> ○ 400/33 kV, 1x50 MVA ICT along with bays : 2 Nos. ○ 125 MVAR 420 kV bus reactor- 2 Nos. (one on each section) ○ 400 kV reactor bay- 2 Nos. (one on each section) ○ 400 kV Bus sectionaliser- 1 Set
	○ 400 kV line bays – 6 Nos. (3 on each section)	

Transmission Service Agreement

	○ 400 kV reactor bay- 2 Nos. (one on each section)	
4.	KPS3 – KPS3 (HVDC) 400 kV 2xD/C (Quad ACSR/AAAC/AL59 moose equivalent) line along with the line bays at both substations	400 kV GIS line bays - 4 Nos. at KPS3 (2 Nos. on each bus section) 400 kV GIS line bays - 4 Nos at KPS3 (HVDC) (2 Nos. on each bus section)
5.	±500 kV HVDC Bipole line between KPS3 (HVDC) and South Olpad (HVDC) (with Dedicated Metallic Return) (capable to evacuate 2500 MW)	

** The 400 kV interconnections (along with all associated equipment/ bus extension, etc.) between HVDC and HVAC switchyards shall be implemented by the TSP*

Note:

- i. The 1250 MW pole-1 shall emanate from 400 kV bus section 1 of KPS3 (HVDC) and terminate at South Olpad S/s. Similarly, the 1250 MW pole-2 shall emanate from 400 kV bus section 2 of KPS3 (HVDC) and terminate at South Olpad S/s.*
- ii. HVDC System will be designed with 100% power reversal capability as well as black start, automatic grid restoration and dynamic reactive power support capability.*
- iii. The rated power transmission capacity as well as the rated transmission voltage shall be defined and guaranteed at the rectifier DC Bus.*
- iv. TSPs of KPS3 shall provide space for scope at Sl. No. 4 as per the above scope*
- v. TSP of South Olpad S/s shall provide space for scope at Sl. No. 2 as per above scope ensuring*
 - (a) indicative total space requirement for HVDC terminal station of size 400 m x 300 m. The AC switchyard connection and DC overhead line shall be from 300 m side of rectangular plot.*
 - (b) the width of the approach road and access road shall be at least 10 m for facilitating smooth transportation of HVDC equipment including converter transformer and with access road all around the space for HVDC.*
 - (c) the spatial arrangement for proposed space for HVDC terminal and the layout proposed for the current AC GIS transmission scheme is such that Bus duct length required for interconnection between AC GIS station and HVDC terminal is minimum to the extent possible in linear manner and the layout of the AC line termination gantries should be such that there is no crossing of present/ future AC lines and HVDC line near the termination ends of both AC and HVDC yards.*
- vi. Implementation timeline: 48 months from SPV transfer*

iii) Transmission Grid Map:

Transmission Grid Map indicating the details of the Project is given below:

Transmission Grid Map

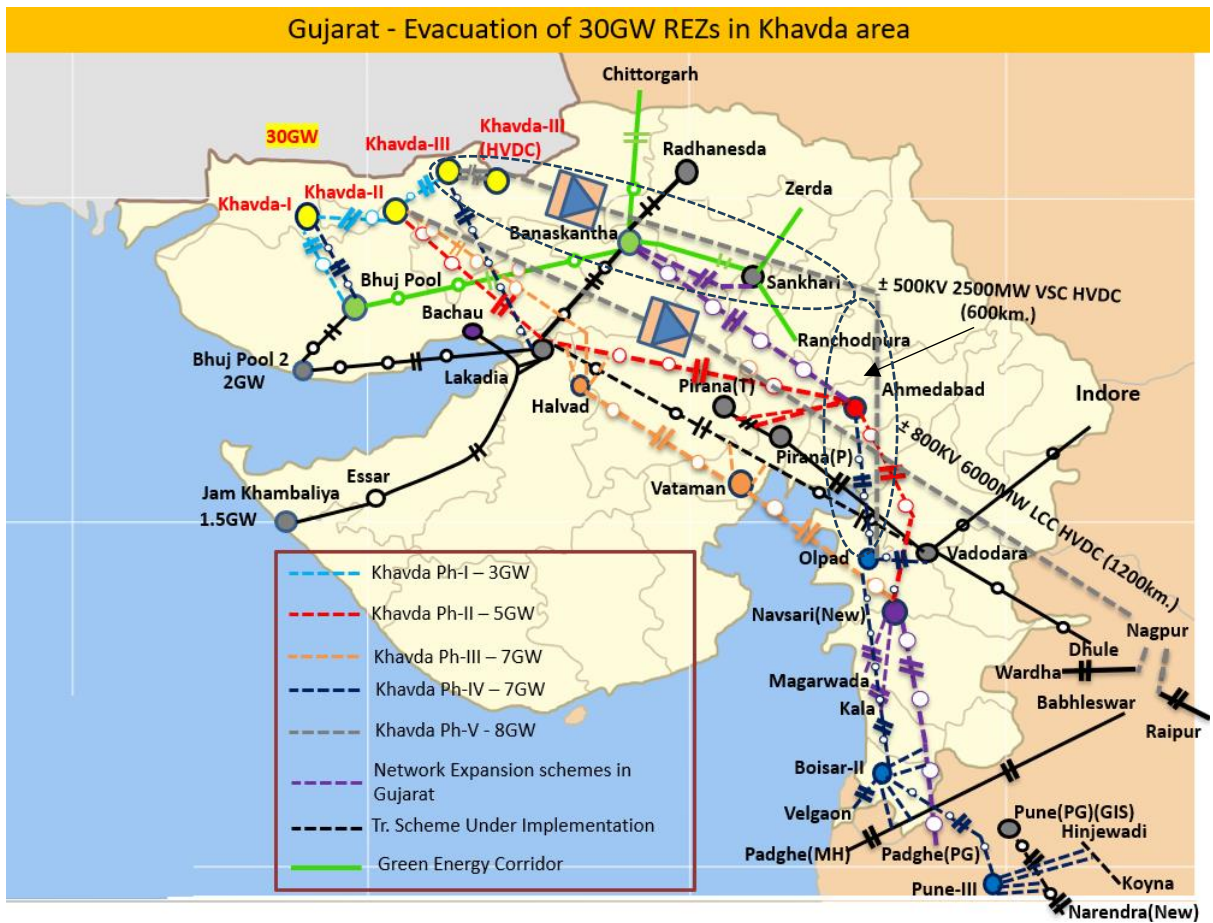

Transmission Service Agreement

Sl. No.	Name of the Transmission Element	Scheduled COD	Percentage of Quoted Transmission Charges recoverable on Scheduled COD of the Element of the Project	Element(s) which are pre-required for declaring the commercial operation (COD) of the respective Element
1.	Establishment of 2500 MW, \pm 500 kV KPS3 (HVDC) [VSC] terminal station (2x1250 MW) at a suitable location near KPS3 substation with associated interconnections with 400 kV HVAC Switchyard*	48 months from SPV transfer	100%	All Elements are required to be commissioned simultaneously as their utilization is dependent on commissioning of each other.
2.	Establishment of 2500 MW, \pm 500 kV South Olpad (HVDC) [VSC] terminal station (2x1250 MW) along with associated interconnections with 400 kV HVAC Switchyard of South Olpad S/s*			
3.	Establishment of KPS3 (HVDC) S/s along with 2x125 MVAR, 420 kV bus reactors along with associated interconnections with HVDC Switchyard*. The 400 kV bus shall be established in 2 sections through 1 set of 400 kV bus sectionaliser to be kept normally OPEN. 400/33 kV, 2x50 MVA transformers for exclusively supplying auxiliary power to HVDC terminal.			
4.	KPS3 – KPS3 (HVDC) 400 kV 2xD/C (Quad ACSR/AAAC/AL59 moose equivalent) line along with the line bays at both substations			
5.	\pm 500 kV HVDC Bipole line between KPS3 (HVDC) and South Olpad (HVDC) (with Dedicated Metallic Return) (capable to evacuate 2500 MW)			

** The 400 kV interconnections (along with all associated equipment/ bus extension, etc.) between HVDC and HVAC switchyards shall be implemented by the TSP*

Location details of existing / proposed substations:

a. South Olpad substation:

Substation is under bidding under separate scheme.

b. KPS3 Substation:

24°12'26.58"N, 69°29'41.53"E

Note: *The above coordinates/location of substation indicated is approximate in the substation area. Exact coordinates for the corresponding bays/gantry for termination of the respective line may be verified and finalized in coordination with actual site.*

Specific Technical Requirement of 2500 MW (2x1250 MW), ±500 kV HVDC

[Type: Voltage Source Converter (VSC)]

1. General

The proposed HVDC link shall be ±500 kV, 2500 MW HVDC line between KPS 3 (Gujarat) and South Olpad (Gujarat) using Dedicated metallic return and consist of Bipole (2x1250 MW). The bipole shall consist of Pole-1 (1250 MW) and Pole-2 (1250 MW). The HVDC terminals shall be implemented with 100% power reversal capability.

The system shall generally conform to the requirements of the Central Electricity Authority (Technical Standards for Construction of Electrical Plants and Electric Lines) Regulations 2022, Central Electricity Authority (Measures relating to Safety and Electric Supply) Regulations, 2023, Central Electricity Authority (Safety requirements for construction, operation and maintenance of electrical plants and electric lines) Regulations, 2011 as amended from time to time and any other relevant Rules/ Regulations/ Standards/ Guidelines.

2. Abbreviations

The following terminology shall apply at various places of this specification:

DMR:	Dedicated Metallic Return
DMRTB:	Dedicated Metallic Return Transfer Breaker
DPS:	Dynamic Performance Studies
ESCR:	Effective Short Circuit Ratio
FAT:	Factory Acceptance Tests
HMI:	Human Machine Interface
HVAC:	High Voltage Alternating Current
HVDC:	High Voltage Direct Current
HVRT:	High Voltage Ride Through
IBR:	Inverter Based Resources
Id:	Direct current (any defined value)
LCC:	Line Commutated Converter
VSC:	Voltage Source Converter
LI/SI:	Lightning Impulse/Switching Impulse
LVRT:	Low Voltage Ride Through

Transmission Service Agreement

NBS:	Neutral Bus Switch
NGBS:	Neutral Ground Bus Switch
PCC:	Point of Common Coupling
POI:	Point of Interconnection
PMR:	Pole Metallic Return
PMRTB:	Pole Metallic Return Transfer Breaker
RPC:	Reactive Power Control
SAS:	Substation Automation System
SCADA:	Supervisory Control and Data Acquisition
SCR:	Short Circuit Ratio
SSTI:	Sub-synchronous Torsional Interaction
TSP:	Transmission Service Provider
Ud:	Direct voltage (any defined value)

3. Definitions

Bipole: A pair of two (2) poles which are connected to opposite polarities (positive and negative). For power transmission in one Bipole, two such pairs are required.

Forward Power flow direction: Active power transmission from Khavda PS3 to South Olpad HVDC.

Inverter: HVDC terminal which is receiving the power.

MMC: (Modular Multi-level Converter): Multi-level converter in which each valve arm consists of multiple power modules connected in series.

MMC building block: self-contained, two-terminal controllable voltage source together with D.C. capacitor(s) and immediate auxiliaries, forming part of a MMC.

PCC (Point of Common Coupling)/ POI (Point of Interconnection): The connection point between the HVDC and the power system at which performance requirements are defined.

Reverse Power flow direction: Active power transmission from South Olpad to Khavda PS3

VSC phase unit: Equipment used to connect the two DC terminals to one AC terminal.

VSC unit: Three VSC phase units, together with VSC unit control equipment, essential protective and switching devices, DC storage capacitors, phase reactors and auxiliaries, if any, used for conversion

VSC converter unit: Individual operative unit comprising all equipment between the point

Transmission Service Agreement

of connection on the AC side and the point of connection on the DC side, essentially one or more VSC converters, together with one or more interface/converter transformers, converter unit control equipment, essential protective and switching devices and auxiliaries, if any, used for conversion.

VSC converter station (HVDC Substation): Part of VSC HVDC system which consists of one or more VSC converter units including DC switchgear, DC fault current controlling devices, if any, installed in a single location together with buildings, reactors, filters, reactive power supply, control, monitoring, protective, measuring and auxiliary equipment.

VSC HVDC system: High-voltage direct current transmission system connecting two VSC converter stations transferring energy in the form of HVDC including related transmission lines and/or cables, switching stations, if any, as well as other equipment and sub-systems needed for operation

STATCOM operation: Mode of operation of a converter when only reactive power (capacitive or inductive) is exchanged with the AC system [Ref: IEC 62747:2019]

SCR: Ratio of the AC network short-circuit level (in MVA) at 1 p.u. voltage at the point of connection to the AC bus of the HVDC substation, to the rated DC power of the HVDC substation (in MW) [Ref: IEC 62747:2019]

Operating state: Condition in which the HVDC substation is energized and the converters are de-blocked [Ref: IEC 62747:2019].

Valve blocking: State condition of a valve when all IGBTs are turned off [Ref: IEC 62747:2019]

In reading of this RfP, term “BIGT” can be used interchangeably for “IGBT”.

Converter blocking: Operation to initiate a mode change from operating state to blocked state of a VSC unit [Ref: IEC 62747:2019].

Converter deblocking: Operation to initiate a mode change from blocked state to operating state of a VSC unit [Ref: IEC 62747:2019].

Inductive operation: Operation in which the converter consumes reactive power from the AC system with or without exchanging active power [Ref: IEC 62747:2019].

Capacitive operation: Operation in which the converter feeds reactive power into the AC system with or without exchanging active power [Ref: IEC 62747:2019].

4. For Definition, relevant standards as mentioned in the clause 51 of this Annexure may be referred.

VSC Transmission configuration:

Transmission Service Agreement

± 500 kV HVDC Bipole system between KPS3 (HVDC) and South Olpad (HVDC) shall be VSC transmission in bipolar configuration with dedicated metallic return as indicated in Fig.1 below.

The PCC points shall be connection of Pole 1 and Pole 2 to 400 kV AC Bus sections at KPS-3 (HVDC) substation and connection of Pole 1 and Pole 2 to 400 kV AC Bus at South Olpad.

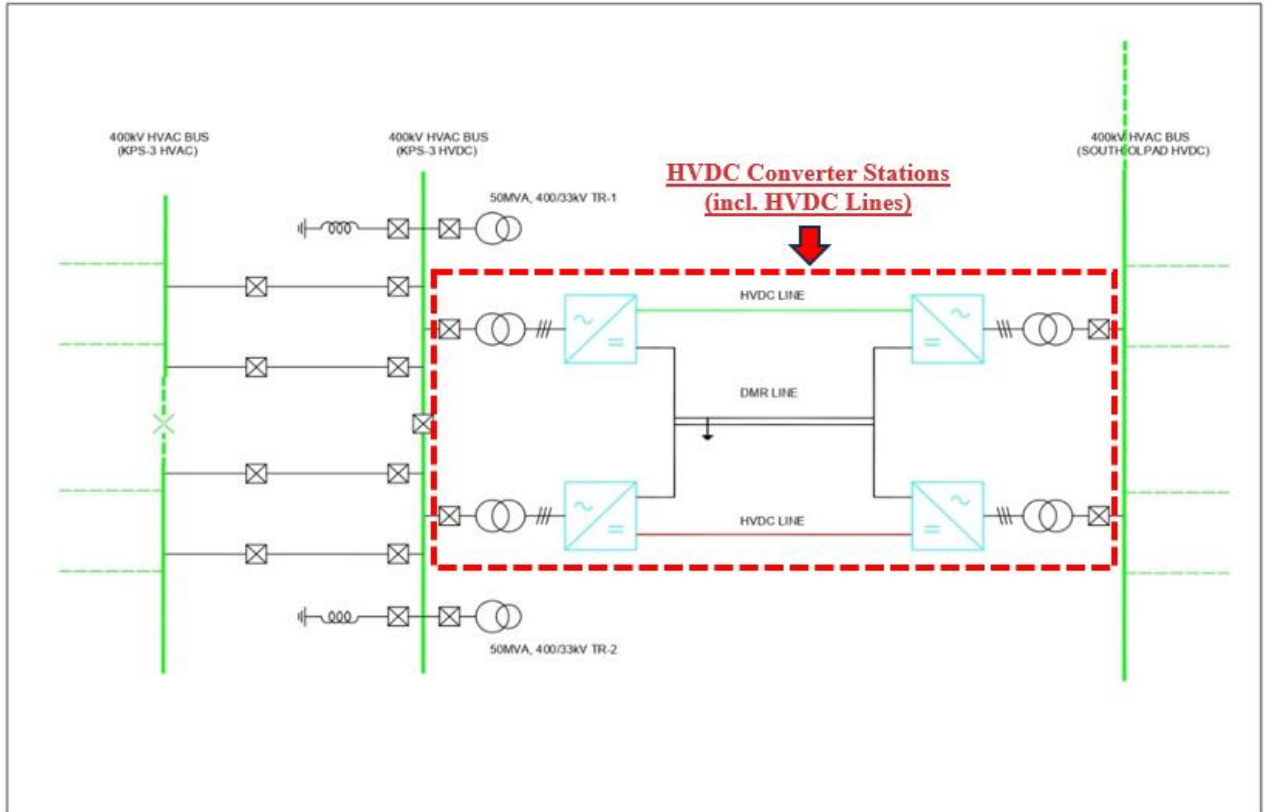

Fig.1: VSC transmission in bipolar configuration with dedicated metallic return

Design Consideration:

The salient technical features for HVDC terminals shall be as follows (Table 1):

Table 1

Sl. No.	Item Description	Parameters
1.	Rectifier station location (Forward direction power)	Near KPS3 (Gujarat) [If the power direction is reversed, Khavda becomes inverter]
2.	Inverter station location (Forward direction power)	South Olpad (Gujarat) [If the power direction is reversed, South Olpad will become rectifier]
3.	Rated DC voltage (1.0 pu)	± 500 kV DC at Rectifier HVDC Pole Bus
4.	Rated power (1.0 pu)	2500 MW at Rectifier DC Bus

Transmission Service Agreement

Sl. No.	Item Description	Parameters
5.	Minimum DC Power	0 MW
6.	AC system frequency	Nominal 50 Hz
7.	Fault Current level AC system	63 kA for 1 sec for Khavda (HVDC) Near KPS3 63 kA for 1 sec for South Olpad
8.	Minimum Short circuit level (MVA) at 400 kV Khavda KPS3 (both rectifier and inverter operation)	14400 MVA# for both Sec-I and Sec-II (with IBR) 12600 MVA# for both Sec-I and Sec-II (without IBR) <i>(Considering outage of 2x1500 MVA ICTs on each section, with 400 kV bus sectionaliser kept open)</i>
9.	Minimum Short circuit level (MVA) at 400 kV South Olpad (both rectifier and inverter operation)	15400 MVA# <i>(Considering outage of 1x1500 MVA ICT)</i>
10.	Reverse power rating	100% of rated forward direction power transfer rating [§]
11.	Reduced voltage	80% of rated DC voltage [Applicable for both power flow directions]
12.	Converter transformer	Single phase two winding design
13.	IGBT/BIGT Valve	Water cooled
14.	Valve cooling system	Dry type design
15.	HVDC control system*	Main + hot standby
16.	HVDC protection system*	Duplicated Protection
17.	Auxiliary supply source	Two supplies shall be fetched from the 33 kV side of 2 Nos. of 400/33 kV transformer (50 MVA) at KPS3 HVDC and 33 kV tertiary of 2 Nos. 765/400/33 kV ICT at South Olpad.
18.	DC Harmonic filter	DC filter for each pole at each HVDC terminal station, if required as per TSP/OEM design
19.	AC Network Impedance	5th Harmonic 1.5% 7th Harmonic 1.0% Other Harmonics 0.5% (each) Further, Relevant CIGRE/ IEC document shall be used for the Network harmonic impedance together with information in PSSE network files provided by CTU.
20.	Negative sequence voltage (fundamental frequency)	1% for Performance 1.5% for rating of equipment
21.	Online fault locator for HVDC pole lines	One No. per pole at each terminal station [when not integrated with Control and

Transmission Service Agreement

Sl. No.	Item Description	Parameters
		Protection System]
22.	Blocking filter	As per requirement
23.	Reliability and Availability Design Targets	As per Table 10
24.	Station Loss evaluation criteria	Methodology as per IEC 61803 and IEC 62751 and Target figures stated in Table 10
25.	System Grounding	Solidly grounded or Resistive Grounding as per OEM Practice

The values of short circuit level are based on available network topology and generalized parameters for various network elements.

* TSP can provide integrated Control and Protection system as well meeting functional requirements.

§ The power reversal in HVDC links shall be possible from the maximum active power transmission capacity from KPS3 (HVDC) to South Olpad (HVDC) to the maximum active power transmission capacity from South Olpad (HVDC) to KPS3 (HVDC) within 60 minutes.

The criteria for the design and control of the network shall be as follows:

- 400 kV AC bus voltages shall normally be within $\pm 5.0\%$ of nominal voltage (400 kV). Bus voltages outside this range may occur from time to time and may exist for long periods due to abnormal loads and/or contingencies. Unless otherwise stated, all equipment shall be rated to operate safely for AC voltages between 360 kV – 440 kV at the converter stations.
- AC system frequency shall normally be within 48.5 Hz to 51 Hz and the HVDC system shall operate in this range without any restrictions on power transfer. However, equipment shall be rated for 47.5 Hz to 52.5 Hz band except AC/ DC filters, if any.
- For calculating reactive power exchange and filter performance (if any), the 400 kV AC voltage variations to be taken, shall be from 380 kV to 420 kV and the frequency shall be from 49.0 Hz to 50.5 Hz. Frequency range for AC/DC filter (if any) rating shall be 48.5 Hz to 51 Hz.

5. Environmental Data

The environmental data shall be considered as per following Table-2:

Table 2

Transmission Service Agreement

Sr. No.	System data	Khavda (HVDC) Near KPS3	South Olpad
1	Max/ min Ambient temperature (dry bulb one-hour average) Max dry bulb 24 hr average	50 deg C max 0 deg C min 40 deg C	50 deg C max 0 deg C min 40 deg C
2	Relative Humidity (% , max)	100	100
3	Average annual rainfall	As per rainfall map of IMD	As per rainfall map of IMD
4	Iso-keranic level	As applicable	As applicable
5	Wind Zone	As per National Building Code 2016	As per National Building Code 2016
6	Seismic Level	As per Seismic zone of the site	As per Seismic zone of the site
7	Altitude above sea level	< 1000 m	< 1000 m
8	Pollution level (IEC 60815)	Heavy	Heavy

6. System Performance

The HVDC system shall be designed to meet all performance requirements and shall be compatible with the existing power system. The HVDC system shall not cause instability to the existing AC network. Also, it shall not cause adverse effects to other HVDC system(s) in vicinity, solar based generation plants (near Khavda KPS-3) as well as other Generating Units. This shall be verified by stability, multi-infeed and Sub Synchronous Resonance (SSR) studies and any other Study required, if applicable. The steady state, dynamic, HVRT, LVRT, Harmonic and flicker performance requirements as per applicable Rule/ Regulations/ Standards/ Guidelines shall be applicable.

The rated power transmission capacity shall be defined and guaranteed at Rectifier DC Bus and rated transmission voltage shall be defined at the rectifier DC bus. In the calculation of the power transmission capability, the most unfavourable combination of control and measurement tolerances shall be considered and without redundant cooling and submodules. All components of the transmission system shall be rated to meet the requirements given in this section and other requirements specified elsewhere in this Specification.

HVDC system performance and rating requirements for high voltage equipment and other critical equipment shall be determined taking into account the extreme values of environmental and AC and DC system parameters as applicable for performance/rating requirements given in this specification and manufacturing and measuring tolerances.

TSP shall determine the PQ diagram of the individual converters as well as the total DC transmission system. The PQ diagram shall be valid for all 400 kV AC bus voltages in the range of 380 kV to 420 kV and for all frequencies in the range of 48.5 Hz to 51.0 Hz. The PQ

Transmission Service Agreement

diagram shall also show, where applicable, different limits for 47.5 Hz to 52.5 Hz and for bus bar voltages in the range of 360 kV to 440 kV.

Mode	Power Range	Min Capacitive Reactive power per pole (MVar)	Min Inductive reactive power per pole (MVar)
Pole Power	0-1250 MW	410	410
Pole in STATCOM mode	0	625	625

There shall be no restriction on connecting, starting and operating the HVDC link if frequency and AC voltage at rectifier station are within 48.5-51.0 Hz and 380 - 420 kV respectively. Khavda end of link shall be operated as a grid forming facility that provides 50 Hz power frequency and controls the AC voltage level at 400 kV bus.

For calculations, the maximum line resistance shall be taken at a maximum conductor temperature of 85°C with minimum wind velocity and maximum solar radiation while for minimum line resistance the conductor temperature shall be taken as 0°C.

7. DC Voltage:

The nominal direct voltage at the Rectifier converter station shall be ± 500 kV relative to neutral. This voltage shall be maintained within ± 10 kV by tap changer and modulation index control for all power flows with balanced current between the poles/converters for all AC bus bar voltages between 380 kV and 420 kV and for all AC system frequencies between 49.0 Hz and 50.5 Hz.

In any monopolar operation, the rectifier Pole Voltage to Ground may be decreased by equivalent Voltage drop in DMR line.

In the event that the AC system voltage is below 380 kV, down to 360 kV, the DC line voltage may be correspondingly reduced.

If the AC system voltage at Rectifier or Inverter end is above 420 kV but not exceeding 440 kV, the DC line voltage to ground may be increased but shall not exceed 525 kV at Rectifier. The above references to DC pole voltages shall be interpreted as extremes and shall not be exceeded due to measurement error, tap changer control dead band, tolerances in the manufacture or in the control system, harmonics or for any other reason.

8. Reduced DC Line Voltage

The HVDC system shall be capable of operating continuously at a nominal pole voltage of 400 kV relative to neutral at rectifier DC bus in bipolar as well as in monopole modes. Rectifier station shall be capable of transmitting power flows upto 2000 MW in bipolar link and 1000 MW in Monopole. Redundant cooling may be in service. The pole voltage shall be within 10 kV of the above, provided that the AC bus voltage is below 400 kV.

Transmission Service Agreement

It shall also be possible to set DC voltage reference between 400 kV to 500 kV in either pole in the steps of 1 kV by the operator action.

Power levels in this voltage range shall be as permitted by the main circuit rating of the equipment. However, reduced voltage attempt by DC line protection shall directly first achieve 400 kV. The reduced voltage may be achieved by a combination of tap changer and modulation index control.

Reduced voltage operation shall be possible to be ordered by operator from either station. The change from normal to reduced voltage operation and vice versa shall not require a converter block or reduction in power below that achievable with the reduced voltage. It shall be possible to start the transmission in reduced voltage mode.

9. Converters Operating modes

The HVDC equipment at both Converter Stations shall be designed and rated to operate with different DC power orders. Necessary facilities shall be provided to permit these modes of operation and to allow the individual Pole power and/or voltage to be set as per below.

Each Pole and Bipole shall be capable of transmitting power for the system short circuit levels specified in this specification. These operating modes shall also be available for reverse power and reduced voltage operation. The poles should have the facility to operate independently with capability to transfer any excess power requirement from one pole to the other in the event of a trip of one pole. The healthy pole shall be limited to its rated capacity.

The minimum operating modes are as follows:

- (a) **Balanced Bipolar:** This mode is the normal mode of operation for the link. In this mode DC currents in the two poles should be balanced and any small unbalance current between the poles should flow through DMR.
- (b) **Unbalanced bipolar operation:** Two poles running at different power levels and difference in pole currents flowing through DMR.
- (c) Monopolar operation with Dedicated Metallic Return (DMR i.e., D1 or D2 or D1 || D2) mode
- (d) Monopolar operation with Pole Metallic Return (PMR) mode.
- (e) **Constant frequency and AC voltage control mode:** HVDC station at Khavda is

Transmission Service Agreement

connected to HVAC network integrated with renewable solar and wind generators. During disturbances HVAC network at Khavda may get isolated therefore the HVDC station at rectifier shall always operate as a grid forming facility that provides 50 Hz power frequency and control the AC voltage at 400 kV level. The operator shall be able to set an appropriate droop in the AC voltage control to achieve a reasonable contingency reserve and sharing of reactive power with other reactive power in the system

- (f) **Reactive Power and AC voltage control mode:** each Converter Station shall be designed and able to independently control the reactive power or the AC voltage. The operator shall be able to select between the reactive power and AC voltage control modes and shall also be able to select the reference values for Q/U_{ac} . The voltage control strategy should not result in excessively high tap changer operations of converter transformers. AC voltage and reactive power control of each converter station shall operate stably with nearby reactive power compensation devices. Any oscillations of power and voltage at the HVDC converter shall be well damped and eliminated.
- (g) **STATCOM mode:** In case HVDC pole is not transmitting power, healthy converter shall be capable of operating independently under Statcom Mode. The operator shall be able to activate Statcom mode separately for each converter station.
- (h) **Black start:** Facility for Black start capability shall be possible for both the stations. TSP shall determine and provide any additional equipment such as diesel back up, batteries, etc. that is required to be able to carry out black start in both directions. This shall include any hardware and all the necessary control functions to perform the black start.

10. System Studies

The TSP shall be responsible for overall system engineering and detailed design of all elements, systems, facilities and equipment. The TSP shall have to carry out following studies and shall submit the study reports for this purpose for both directions of power flow. The TSP may note that the following list is only indicative and if any other studies, calculations etc. are required the same shall have to be done by TSP.

- (a) Main circuit parameters
- (b) Transient Current Requirement and Short circuit studies
- (c) Thermal Rating Study for Key Equipment
- (d) Studies for Overvoltage Protection and Insulation co-ordination for AC and DC

Transmission Service Agreement

systems

- (e) AC, DC Harmonics (if applicable, required as per OEM's design) filter design, rating and performance
- (f) Temporary overvoltage (TOV) and Fundamental Frequency Temporary Over Voltage- (FFTOV) and Ferro Resonance Overvoltage Studies
- (g) AC and DC Transient overvoltage Study, surge arrester stress
- (h) Runback and run up studies (the Last Line/ Last Breaker logic (if required) shall be limited to the AC lines and AC breakers within the HVDC stations)
- (i) AC breaker Transient Recovery Voltage (TRV) and rate of rise of recovery voltage (RRRV) studies
- (j) DC High Speed Switch Requirement Study (as applicable)
- (k) AC equivalent study

The equivalents to be prepared for peak load, light load and extremely weak (minimum SCR) network scenarios. The dynamic network equivalent shall be prepared with full machine models having exciters, governor-turbine, generators, stabilizer models instead of voltage source models, up to a minimum of two buses away. These dynamic equivalent networks shall be used in PSCAD DPS, Real Time Digital Simulator (RTDS) DPS, with actual control and Protection panels.

- (l) DC Commutation switch requirements (as applicable)
- (m) Load flow, stability, modulation and frequency controller design study
- (n) LVRT, HVRT, harmonic resonance and other dynamic studies
- (o) Black start islanded operation studies at both ends
- (p) Electrical interference (RI and PLC) study , filter design, rating and performance
- (q) Reliability and availability study
- (r) Audible noise study
- (s) Loss calculations/study
- (t) Studies for deciding the operational logic and sequences considering Dedicated Metallic Return Conductor (DMR) operation and Metallic return with pole conductor, in case of monopolar Operation
- (u) Impact of parallel AC lines
- (v) Real Time Simulator-based studies for testing of actual HVDC Controls (Factory Acceptance Test or Factory System Test)
- (w) AC/ DC system interaction studies

Transmission Service Agreement

- (x) Interaction studies between this VSC HVDC and other nearby HVDC stations and nearby Inverter Based Resources (IBR)
- (y) Studies to determine the requirements for communication between the converter stations and remote Load Despatch Centres (LDCs).
- (z) Studies for designing the equipment for Dedicated Metallic Return Conductor (DMR) operation and metallic return with pole conductor, in case of monopolar operation up to rated power.
- (aa) Sub synchronous Resonance and Self Excitation Studies

These studies shall be carried out to demonstrate that the HVDC system does not excite the torsional modes of oscillations and self-excitation of the generators and Sub-synchronous Resonance in thermal/gas turbine generators near Converter Stations under all defined system operating conditions. The study shall demonstrate that the HVDC system has positive damping for all sub synchronous torsional modes of the generators.
- (bb) Studies of DC Current flowing through Windings of Converter Transformers
- (cc) Studies of DC Current flowing through breakers on AC side of converter transformer for earth faults on converter side of transformer at locations as applicable and sizing of auxiliary resistor to ensure zero crossings in the total current in the AC breaker.
- (dd) AC line and other bays protection co-ordination studies in grid forming mode.
- (ee) Studies for the Control, Protection and Communication Systems
- (ff) DC over voltage studies
- (gg) Low frequency characteristics
- (hh) High frequency characteristics
- (ii) Station earthing

The study reports shall include the following study results:

- (i) Dynamic Performance Study including the RE Resources near Converter Stations
- (ii) Hierarchical Structure of the Control and Protection
- (iii) Redundancy of the Control and Protection Systems
- (iv) DC Power and Voltage Control Modes and Features
- (v) Switching Sequences and interlocking
- (vi) AC and DC System Protections

Transmission Service Agreement

For each protection, the report shall include the following:

- a) Purpose of the protection
- b) Principle of protection operation
- c) Required accuracy of measuring signals
- d) Fault detection and coordination between the DC controls and the protection and AC protection.
- e) Consequences of protection operation, such as DC control and sequence control initiated at both converter stations
- f) Redundancy of protection and operation of backup protection
- g) Detailed calculations of the protection settings together with limiting fault cases and/or criteria that determine these settings.
- h) Description of the applicable protection in case of loss of telecommunication.

(vii) Reactive Power Control

The study shall include at least the following:

- a) Reactive power control principles for converter operation during steady state and transient conditions including STATCOM mode of operation
- b) Switchover and control feature between AC voltage/reactive power controls
- c) Reference variable control criteria
- d) Criteria for switching of reactive power sub banks, as applicable.
- e) Operator operation, including control and monitoring features
- f) Equipment description, emphasizing reliability/availability and maintenance features
- g) Validity checking of signals

(viii) Telecommunication Interface Requirements

(ix) Station Control and SCADA System

(x) Control for Converter Transformer Tap changer

(xi) Additional Control Study

Transmission Service Agreement

The report, as applicable shall include the studies of the following control modes with the AC network condition of Khavda and South Olpad and actual performance of converter equipment and possible fault condition being taken into account.

- a) Power ramp down
 - b) Power ramp up
 - c) Damping of sub-synchronous oscillations
 - d) Abnormal AC voltage and frequency control
 - e) Supplementary modulation signals
 - f) Fault current infeed studies
 - g) Negative sequence current infeed studies
- (xii) Multi Infeed Interaction Study with nearby HVDC Systems
- (xiii) Black Start Mode network studies.
- (jj) Any other studies as deemed necessary by TSP

TSP shall carry out necessary studies for performance under this RfP considering the 400 kV Bus-sectionalizer at KPS-3 (S/s) in both Open and closed condition.

The load flow and dynamic file shall be provided to the TSP in PSS/E 34 or newer version format. This will include maximum and minimum fault contribution from conventional generation and IBRs considering full power, reduced dc voltage power, black Start modes and other network scenarios which can lead to highest possible dynamic overvoltage variations. Necessary Generic Models for IBRs or modelling assumptions shall also be provided for studies requiring the same. Conventional generator, lumped mass model and controller models in vicinity shall also be provided. For sharing User defined Models (UDMs) TSP and Solution Providers will be required to abide with the statutory requirements of the UDM provider if required.

In case of absence of detailed models of nearby inverters and 6000 MW LCC HVDC, the harmonic distortions shall be considered as per the relevant CEA Regulations. The impedance of RE Park at the Pooling station PCC will be provided to the TSP. The rest of the network may be modelled by the harmonic impedance and the rating and performance studies shall be done accordingly. Harmonic impedance shall take into account all

contingencies in base file, N-1, N-2 and other PSS/E scenarios for network for full power and reduced DC power.

PSS/E files shall be provided based on the data available at the time of issuance of the RfP. The TSP is required to validate the data before carrying out simulation. However, clarification, if any, may be sought before the bid submission. CEA/ CTU shall endeavour to give clarification to the extent possible. In case of any discrepancy observed/ non-availability of data for any of the machines and other control devices, typical values may be used in the studies with the intimation to CEA/ CTU.

11. Digital Models

TSP shall provide to CTU following models of all supplied circuit components and control and protection of the HVDC Systems. The models shall be up to date with all the design features implemented in the Project.

- (a) PSCAD
- (b) PSS/E

TSP shall provide both UDM and Generic model for RMS based stability model (in PSS/E V36 or above) and EMT (PSCAD). All appropriate control features shall be modelled in the above models and necessary documentation on the theory and use of model should be provided. Further, a generic model, benchmarked to the extent possible to the UDM PSS/E and PSCAD model, shall also be furnished. Generic models can be shared by the CEA, CTU and Grid-India with the concerned stakeholders/**external party(ies)** e. g. STUs etc. **on need basis**. For User Defined model, confidentiality shall be maintained by the CEA, CTU and Grid-India. For PSCAD, User Defined model shall be provided by the TSP for which confidentiality shall be maintained by the CEA, CTU and Grid-India. Both UDM (PSCAD and PSS/E) and Generic model (PSSE) shall be provided by OEMs to CEA/CTU/GRID-INDIA without any NDA (Non-Disclosure Agreement)

Data sharing requirements as per Procedure for First Time Charging/ Energization (FTC) and Integration of New or Modified Power System Element to Grid Controller of India Ltd. (GRID-INDIA) shall also be done by the TSP. All the requisite data/ reports/ models including User defined models/ documents as required as per the CEA/CTU/Grid India Standards/ Guidelines shall be provided by the TSP. Data sharing format will be subject to the agreement or other statutory requirements mandated by HVDC Solution Providers if required.

12. DC power circuit switching requirement:

The TSP shall provide all DC switching devices as per the requirements of this Specification to enable the smooth and efficient operation of the HVDC system. TSP may decide at which end DMR shall be connected to earth based on the practices being followed by the Original Equipment Manufacturer (OEM).

All disconnectors or isolators which are used to provide isolation for maintenance on any

Transmission Service Agreement

equipment shall have visible breaks. If a visible break is not inherent then an additional separate isolator having a visible break shall be provided.

The equipment arrangement shall be designed to ensure that no single contingency, fault or loss of any piece of equipment except common equipment to both the poles can cause or result in a bipolar shutdown or transient reduction in power transfer to less than the rating of one Pole.

High speed switches for discharge of the DC line shall be provided with disconnectors.

The station layout shall provide safe access to all equipment for service and maintenance.

The DC power circuit arrangement shall provide at least the following functions:

- (a) Isolating and grounding Converter Station Pole for maintenance.
- (b) Isolating and grounding either or both DC transmission line Poles for maintenance.
- (c) Isolating and grounding the DMR conductor at the Converter Station for maintenance when operating in bipolar mode with balanced DC currents. All primary equipment, control, protection and measuring equipment necessary to achieve this function shall be provided. All the studies and design engineering necessary for the HVDC System to operate in such modes shall be performed.
- (d) Clearing of a Pole for maintenance without affecting the power flow on the other Pole.
- (e) Switching between active power transmission and STATCOM mode
- (f) Grounding of the neutral bus through a high-speed switch (NBGS) during bipolar operation balanced current mode.
- (g) Clearing neutral bus fault on one Pole.

13. Insulation co-ordination

- (a) HVDC System shall be suitably protected against Impulses and disturbances external and internal to the system such as switching impulses, lighting impulses, steep front impulses, dynamic over voltages and load rejection (1 pu power). The insulation of all equipment shall be properly protected and coordinated with surge arresters and/or surge capacitors. Insulation coordination shall be done keeping in mind the minimum electrical clearances, safety clearances and maintenance clearances as per Switching Impulse Withstand Level (SIWL). Insulation coordination shall be done as per relevant IS/ IEC Standards.
- (b) The insulation of the equipment and protection levels of Surge Arresters connected to the converter AC bus bars of the converter stations at both rectifiers and inverter shall be coordinated with the insulation and surge arrester characteristics of the connected AC systems to which the converter stations are to be connected without exceeding the

Transmission Service Agreement

discharge duty of these arresters so as not to overload these existing arresters of the network. Only 336 kV surge arrester (rated voltage) shall be used on 400 kV AC incoming line side.

- (c) The tripping action for lines shall be initiated if the fundamental frequency over voltage exceeds 1.1 pu for 5 seconds and if 1.5 pu fundamental frequency voltage persists for more than 100 milliseconds. The HVDC over voltage strategy shall be coordinated with such setting.
- (d) The minimum **insulation levels** for 500 kV DC transmission line to ground shall be as per CEA Regulations:
 - Lightning impulse withstand voltage (1.2/50 micro sec) (kVp): 1800 kV
 - Switching surge withstand voltage under wet condition (kVp): 1000 kV
- (e) The ratio of **impulse withstand voltage** to impulse protective level shall be in line with Table 3 of IEC-60071-11.
- (f) The TSP shall carry out insulation coordination studies for the Project. The TSP shall perform all necessary HVDC digital simulator studies and shall keep detailed report(s) on insulation coordination in its record. The TSP shall carry out insulation coordination studies for rating of all arresters supplied for the project, establishing the required insulation level for supplied equipment and the clearances between energized parts and between energized parts and the ground. The arrester arrangement and protective levels shall be selected such that, generally, the overvoltage on the AC side is protected by arresters on the AC side, and overvoltage on the DC side are adequately limited by an arrangement of arresters on the DC side. Critical components of the supplied converter equipment shall be directly protected by arresters connected closest to them. The arresters installed shall be rated such that these arresters are not overstressed for all operating modes and configurations. The studies must show that any existing 420 kV equipment including any existing surge arrestors will not be overstressed for all modes of operation and configurations of either Converter Station when HVDC station is extension of an existing AC station.

The report(s) shall detail the characteristics of the surge arresters, energy ratings and shall demonstrate that the selected insulation protective and withstand levels, discharge and coordinating currents, and arrester ratings and discharge capabilities are adequately coordinated and comply with the requirements of this Specification. It shall also detail all insulation and air clearances and leakage distances and shall justify the selected values based on the present Specifications. The report(s) shall include all assumptions made for the study parameters and describe the types of events modeled (i.e. AC and DC faults, transformer bushing faults, converter valve or control mis-

operations, etc.) and identify the decisive cases that establish the insulation design.

(g) **Temporary Overvoltage**

High voltages at the converter buses can occur due to load rejections or other cause. The HVDC system shall remain connected and provide dynamic voltage control to mitigate the voltage rise within the capability of the equipment. The requirement for ac system voltage control during an overvoltage has highest priority and therefore it is permissible to run back the active power transfer to limit the overvoltage.

The converter valves shall be capable of continuing to operate under the temporary overvoltage conditions specified below, which could occur with the valves deblocked and also that the valves are capable of deblocking under the highest temporary over voltage conditions within five (5) cycles of the initiation of a fault or disturbance. The equipment shall be designed for the applicable short circuit ratio and overvoltage arising thereby.

Temporary Overvoltage caused by Bipole link HVDC transmission shall be controlled to 1.4 pu or below. Temporary overvoltage caused by other equipment in the AC network shall be controlled within the limits of the capability of the deblocked converter. In case of DC line permanent fault, the converters should restart in STATCOM mode for AC grid support. In case the converter is tripped, and not possible to restart within seconds, filter tripping shall be allowed to limit overvoltage as applicable.

The actual temporary overvoltage shall be determined by the TSP, but the equipment shall be designed for temporary over voltage not less than the values given above. In addition, so as to prevent operation and overstressing of the arresters, the TSP shall limit the temporary over voltages including harmonic, resonant, and ferro-resonant effects on the 400 kV AC bus bars so that:

- **705 kV** crest phase to ground is not exceeded by more than 3 peaks;
- **565 kV** crest phase to ground is not exceeded by more than 10 cycles;
- **510 kV** crest phase to ground is not exceeded by more than 20 cycles.

In the calculation of temporary over voltages on the AC side the TSP shall allow for blocking of the complete Bipole from up to the highest steady state transmission capability of the installation. On the DC side the TSP shall allow for the maximum load rejection which could occur and which leaves converter deblocked.

The converter Equipment shall be designed to withstand temporary over voltages corresponding to AC Side which are not less than 1.5 times 400 kV upto 100ms at converter stations with the converter blocked

Transmission Service Agreement

The TSP shall provide and commission all equipment necessary to limit the temporary over voltages on the AC bus bars to the levels specified above. The actual temporary overvoltage shall be determined by the TSP but AC equipment shall be designed for temporary overvoltage not less than the values given above.

The connected AC harmonic filter shall be assumed to be that with the highest MVAR applicable to the mode of operation which does not exceed the maximum reactive power exchange with the AC system as specified in this specification.

The converter equipment shall be rated for continued operation under the maximum over voltage conditions to be defined by the TSP taking into consideration the dynamic over voltage profiles as determined by the design studies to be performed by the TSP. Irrespective of the over voltage profile derived by the TSP, the equipment shall be rated to withstand an over voltage according to above figures following deblocking.

DC withstand voltage design of equipment shall take due consideration of the temporary voltage stresses that the respective equipment may be exposed to based on studies of different disturbances as applicable.

Any switching equipment within the scope of supply of the TSP which may be called upon to operate at this voltage in either a main or backup role shall have the appropriate capability.

HVRT Strategy:

The HVDC Station shall enter into HVRT mode (exit from continuous operating region) when the Voltage at AC bus i.e. 400 kV side (RMS) is above 1.1p.u. due to faults/control actions/or any other cause.

The HVDC Station shall remain connected to the grid when voltage at the interconnection point (AC bus), on any or all phases (symmetrical or asymmetrical overvoltage conditions) rises above the specified values given below for specified time:

Over voltage (pu#)	Minimum time to remain connected and Deliver the rated reactive support (Second) at POI
V > 1.50	Instantaneous trip

Transmission Service Agreement

$1.50 \geq V > 1.30$	100 ms
$1.30 \geq V > 1.10$	10 sec
$1.10 \geq V > 1.05$	15 minutes
$V \leq 1.05$	Continuous

1 pu = 400 kV (3 phase RMS voltage at POI)

During HVRT mode, HVDC Station shall provide reactive power support (absorption) at POI proportional to Voltage at POI (inductive operation). There shall be maximum VSC current (up to 0.8 p.u.) during inductive operation considering voltage of 1.3 p.u. at AC side (POI). 1 p.u. of VSC current is the current corresponding to 1 p.u. of apparent power (1250 MW per pole active power and 410 MVAR per pole reactive power) under nominal system condition.

LVRT Strategy:

The HVDC Station shall enter into LVRT mode (exit from continuous operating region) when the Voltage at AC bus i.e. 400 kV side (RMS) is below 0.9 p.u. due to faults/control actions/or any other cause.

The HVDC Station must remain connected to the grid when voltage at the interconnection point (AC bus), on any one, two or all phases (symmetrical or asymmetrical overvoltage conditions) dips up to the level depicted by the thick lines in the following curve:

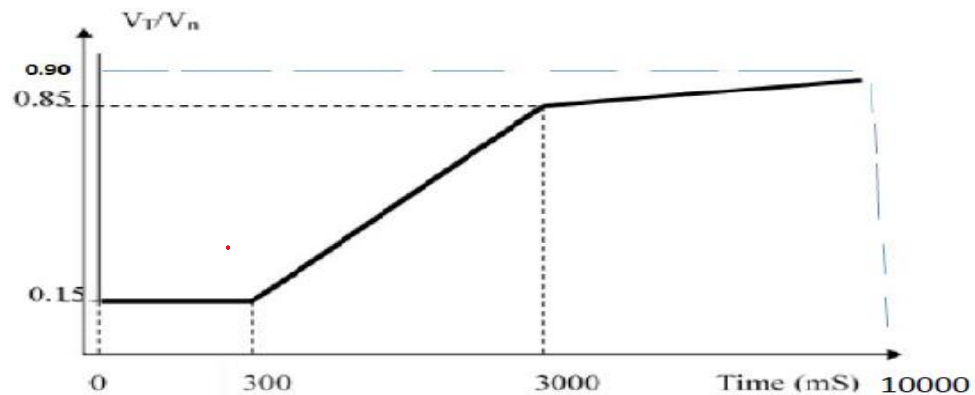

1 p.u. = 400 kV (3 phase RMS voltage at POI)

Transmission Service Agreement

During the voltage dip, the supply of reactive power has first priority, while the supply of active power has second priority. Restoration of voltage shall be said to be achieved when the voltage at POI settles within $\pm 5\%$ of pre fault voltage. Active power shall be restored to at least 90% of the pre-fault level within 1 sec of restoration of voltage.

During LVRT mode, HVDC Station shall withstand all above low voltage conditions and needs to be coordinated to provide reactive power support (injection) at POI with a maximum VSC current of 0.8 p.u. (capacitive operation). 1 p.u. of VSC current is the current corresponding to 1 p.u. of apparent power (1250 MW per pole active power and 410 MVAR per pole reactive power) under normal system condition.

(h) **Transient and Temporary over voltages**

In the calculation of transient over voltages the TSP shall consider at least:

- (i) Lightning surges propagating down the AC and DC overhead lines, including direct strike to line conductors and back flashover.
- (ii) Lightning surges due to direct strike within the converter station in the event of shielding failure
- (iii) Steep fronted waves resulting from flashovers or faults, including those to ground from the valve windings of the converter transformers with tripping of bipole or monopole based on feasibility of survival of healthy pole.
- (iv) Over voltages due to switching of converter transformers, AC filters and shunt capacitors, shunt reactors, 765 kV and 400 kV transmission lines, 765 kV and 400 kV class transformers or other equipment.
- (v) For re-closure of AC filters, residual voltage on the capacitors shall be considered.
- (vi) The saturation effects of converter transformer due to presence of remnant flux shall also be considered.
- (vii) Application and clearing of single phase and three-phase to ground faults which may be cleared by AC circuit breakers; Possibilities of breaker re-strikes shall also be considered although the breaker should be designed as restriking free.
- (viii) Faults within converter equipment, including control and telecommunication malfunctions.
- (ix) Over-voltages due to blocking of converter of monopole or bipole.
- (x) Over-voltages due to DC and DMR line resonance.

Transmission Service Agreement

- (xi) Uneven distribution of over-voltages, particularly within the converter valves.
- (xii) Arrester location relative to protected equipment and arrester characteristics.
- (xiii) For determination of maximum transient and temporary overvoltages at converter bus with a sequence of clearance of three phase /single phase AC bus fault along with the following scenarios shall be checked and highest value shall be considered for suitable protection actions:
 - a. Blocking of one pole or both poles running at full load with appropriate AC filters remaining connected OR
 - b. Highest temporary overvoltage as mentioned in clause 13 g above
- (xiv) Single pole to ground and Pole to Pole fault at DC line or at either station followed by tripping of pole/bipole as applicable.

(i) **Limitation of Overvoltage**

Blocking of the converter valves to protect them and other DC side equipment from sustained over voltages as per table under HVRT Strategy appearing on the AC system shall not be permitted. The use of converter valve group controls to limit temporary (dynamic) over voltages shall be permitted provided that the valves and other converter equipment are adequately rated.

(j) **Determination of Overvoltage**

The TSP shall determine the highest transient and temporary over voltages, which can occur with the equipment parameters selected and with the AC system and DC line as defined in this Specification.

(k) **Arrester Protective Levels**

The transient overvoltage imposed across insulation shall be limited by surge arresters. Dynamic over voltages may also be limited by surge arresters but only if the arresters are adequately rated for such duty.

The discharge current (coordinating current) shall be determined by the TSP appropriate to the arrester location and line and equipment parameters. For arresters connected to the 400 kV AC bus bars, the 8/20 microsecond wave coordinating discharge current shall be 10 kA, 15 kA or 20 kA as appropriate. Where multicolumn arresters are used or where arresters in separate housings are connected in parallel, unequal sharing of the discharge current shall be considered.

The TSP shall design the converter equipment to withstand a maximum continuous AC system voltage of 440 kV. The calculations for determination of arrester energy requirement shall be based on a maximum pre-fault voltage of 440 kV.

(l) **Lightning shield**

The TSP is responsible for the design of the lightning shield. The system shall also be designed to provide "effective shielding" to ensure that almost no insulation flashover can result from atmospheric discharges striking the overhead shielding.

Effective and adequate lightning protection shall be provided to protect all converter equipment including wall bushings and the Converter Station buildings from damage due to atmospheric discharges and shall ensure that any lightning strikes shall not cause flashover or mal-operation of any equipment which can affect the power transmission capability of the Converter Station.

14. Radio Interference (RI), Acoustic Noise (AN) and DC field

- (a) All the necessary precautions shall be made during HVDC design to ensure that there shall be no mal-operation, damage or danger to any equipment, system or personnel due to electromagnetic or electrostatic interference effects. The converter terminal(s) shall neither damage nor cause mal-operation of the DC control and protection system or the DC tele-control system.
- (b) All the necessary precautions shall be taken in the form of noise suppression techniques, shielding and filtering devices to prevent harmful interference, which may be generated by the converter terminals, with the Power Line Carrier (PLC) systems, Radio communication systems, Television systems, VHF, UHF and microwave radio systems.
- (c) The audible noise shall be limited to the following values for various areas of the converter station and buildings. It is to be demonstrated by calculation and site measurement that the specified sound pressure levels are not be exceeded.

Table 5

Valve hall (in places where long term access is required during normal operation) Mechanical equipment indoor areas requiring long term access (measured at 2 meter distance)	90 dBA
--	--------

Transmission Service Agreement

Equipment in outdoor areas (measured at 15 meter distance) except converter transformers	75 dBA
Office area*	45 dBA
Control rooms*	45 dBA
Diesel generator (Operating area)	75 dBA
Compressor areas (measured at 2 meter distance)	90 dBA
At the station boundary (Outside wall or fence)	70 dBA

* "Background" noise from the ventilation system.

- (d) For area with permanent access, the total calculated electric field at ground level shall not exceed 20 kV/m in the DC outdoor yard. For areas with permanent access in DC outdoor yard, calculated Ion current density shall be less than 20 nA/m² at ground level.
- (e) Radio Interference (RI)

The TSP shall take the necessary precautions in the form of valve hall and building shielding to meet his own requirements plus the following:

- (i) With the Bipole operating at any of the specified operating modes and power levels and within the design range of IGBT switching, the Radio Interference Level (RIL) from electromagnetic radiation generated by the converter shall not exceed 100 micro volt/m under fair weather conditions at any point outside station fence which are:

500 meters or more from the nearest bus connecting the valve to the converter transformers within the station

and

at a lateral distance of 30 m for the conductors of any outgoing AC line, HVDC line and DMR line.

This RIL criterion shall be achieved at all frequencies within the range of 150 kHz to 300 MHz.

- (ii) The valve hall design shall incorporate the screening requirements. The use of a mesh screen external to the building, covering all or part of the switchyard shall not be permitted.
- (iii) The shielding shall be designed so that the specified radio interference levels shall not be exceeded assuming any earth resistivity between 10 and 1000

Transmission Service Agreement

ohm-meter.

(iv) Maximum radio interference voltage for frequency between 0.5 MHz to 2 MHz at 1.1 times of maximum DC voltage for 500 kV DC system, 266 kV RMS for 400 kV system and 156 kV RMS for 220 kV system and 92 kV RMS for 132 kV system shall be 2500, 1000, 1000 and 500 micro-Volt respectively.

(f) Television Interference (TVI)

The Television Interference Level (TVIL) shall not exceed 10 micro volts/m at the locations/contour line specified above.

(g) Interference with Power-Line Carrier Systems

The TSP shall take the necessary precautions in the form of noise suppression techniques and filtering devices to prevent harmful interference from the converter stations to Power Line Carrier (PLC) systems operating on the HVAC transmission line networks connected to each station and also to other power line carrier systems located adjacent to the HVDC bipolar line such that PLC systems shall operate reliably in fair weather conditions. The frequency spectra to be protected for PLC system is 40 kHz to 500 kHz.

15. Dynamic Performance

(a) The purpose of dynamic performance design is to determine the control parameters for HVDC system and to ensure that the HVDC system shall have smooth, stable and fast operation for both steady state and transient conditions without adversely affecting the connected AC grid.

The principal objectives of the design shall include:

1. Optimal response of HVDC controls following step change in ordered parameters like current, power, DC voltage etc.
2. Stable operation of the DC system following major disturbances.
3. Stabilization of the ac system following major disturbances.
4. Control of temporary over voltages and avoidance of self-excitation of the generators.
5. Control of frequency following quasi-static (slow) and fast changes in ac system load / generation at the rectifiers and/or inverter ends.
6. Control of power levels depending on the system configuration. Such a control may require ac line load control (ACLCC) and Run Back control features.

Transmission Service Agreement

(b) The HVDC system shall recover to 90% of the pre-fault DC power transfer level consistently within 100 ms from the instant of fault clearing, without subsequent sustained oscillation for all inverter AC system fault conditions. For all rectifiers AC system fault conditions, the recovery time, to 90% pre-fault power level, shall be within 100 ms from the instant of fault clearing. The TSP shall verify that such response time does not give rise for any risk of AC system instability in any system configuration. If it is in the interest of the overall improved recovery of the AC/ DC system, in such cases the recovery times other than those specified shall also be acceptable, subject to review.

(c) HVDC should continue operation at reduced power if conditions get outside the voltage, frequency and short circuit capacity ranges specified in system data as much as possible with its inherent capability.

HVDC terminal Characteristic and Step responses: The response time (tr1) is defined as the time from the initiation of the order change to the time when 90% of the ordered change has been accomplished, subject to the condition that the measured value remains at the new order within a tolerance of +10% of the ordered change at rectifiers DC terminal after the first overshoot. If the measured value exceeds the tolerance of +10% of the ordered change after the first overshoot, then the response time (tr2) shall be defined to be the interval from the initiation of the order change to the time when the measured value returns to and thereafter remains at the new order within a tolerance of +10% of the ordered change. The first overshoot shall not exceed 30% of the ordered change and the measured value shall settle at the new order within a tolerance of +2% by the second overshoot. For an over damped system, the response times (tr3) is defined as the time from initiation of the order change to the time when 90% of the ordered change has been accomplished. The measured value shall settle at the new order within a tolerance of +2% by four times tr3. Step response to changes in power (current) order shall be executed in the following manner:

When the ordered change is *positive*:

Transmission Service Agreement

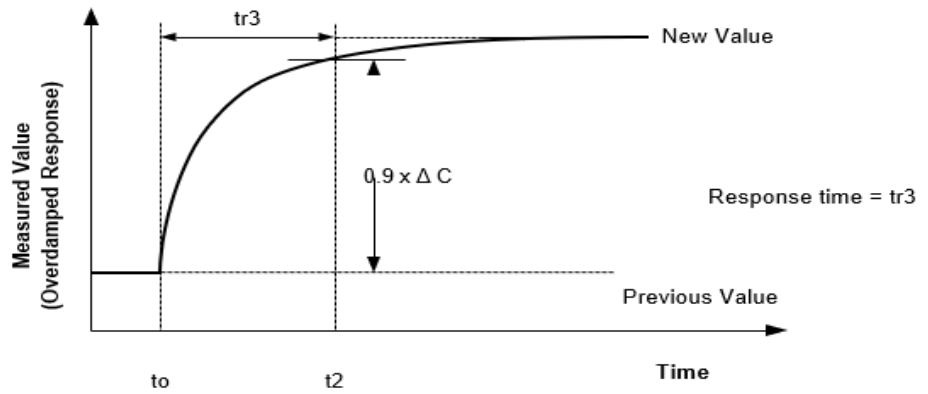
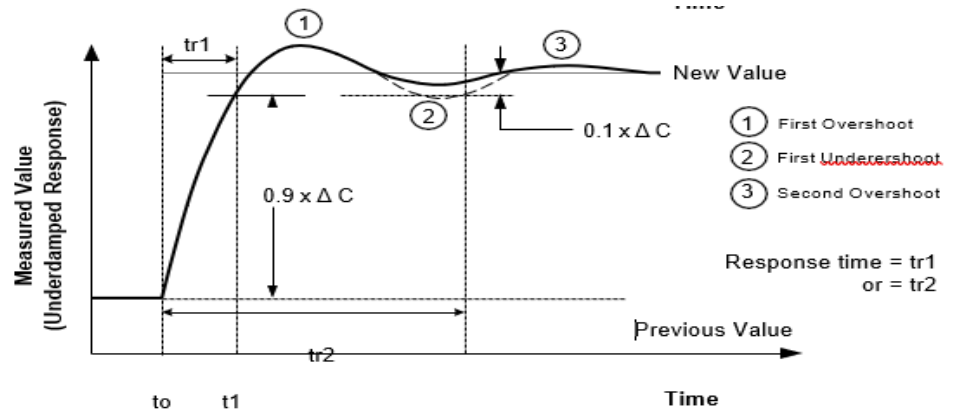
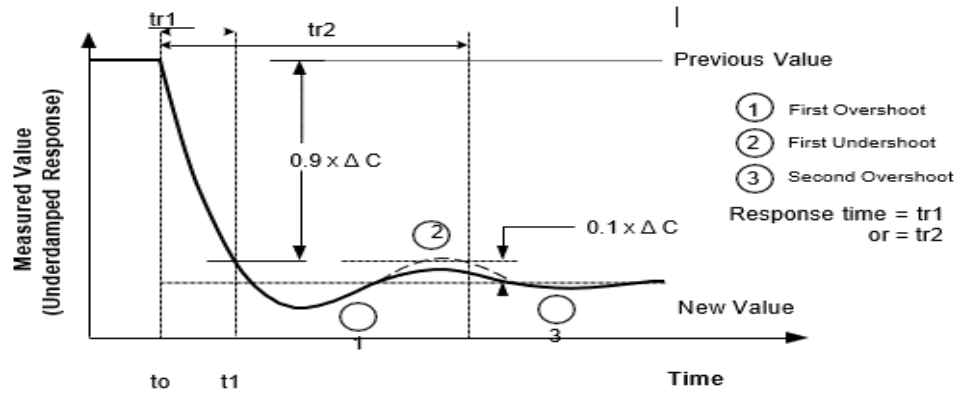

Fig 2- Definition of response to positive step change

When the ordered change is *negative*:



Transmission Service Agreement

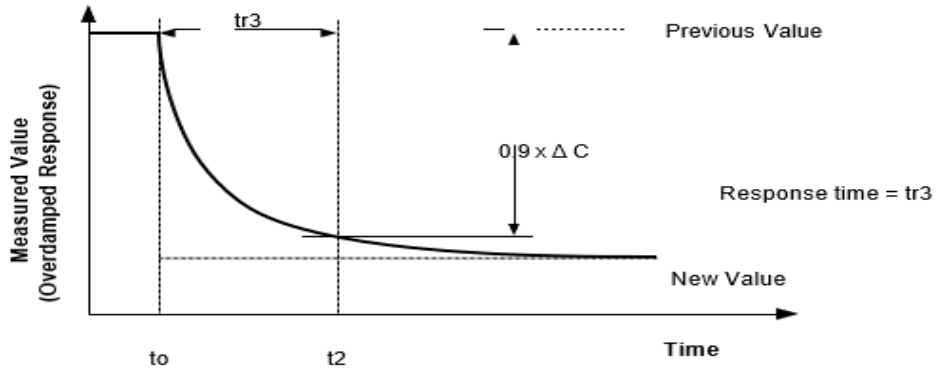

Fig 3- Definition of response to negative step change

(d) Power Order Step Response

The HVDC controls, when in power control mode or any other mode where the DC power transfer is controlled, shall respond to maintain the power transfer of the Poles at the ordered or desired level at any power level between minimum and rated capacity of the HVDC system.

When operating at any power order between the minimum and rated power transfer, the DC power controller shall respond to either a step increase or a step decrease in DC power order such that 90% of the ordered change is achieved within 150 milliseconds of the power order change at the rectifier. The TSP shall verify that such response time does not give rise for any risk of AC system instability in any system configuration. If it is in the interest of the overall improved recovery of the AC/ DC system, in such cases the recovery times other than those specified above shall also be acceptable.

(e) Response to AC Bus Voltage Change

The TSP shall demonstrate the response of the power controls to sudden changes in AC bus voltages of -5.0% to + 2.0% from its nominal value and ensure that it is stable.

(f) Power Voltage Instability

HVDC links operating in constant DC power control and weak AC system conditions can lead to power voltage instability under certain disturbances. To prevent such power voltage instability, the TSP shall provide control measures to prevent AC system collapse during AC system disturbance due to the action of the HVDC control. The TSP may adopt change over to grid forming mode and a power reduction or a dynamic gain supervision function in the control system to avoid such

instability if the short circuit MVA changes during a particular power transmission level.

16. Main Circuit Design

The purpose of Main Circuit design is mainly to determine the operating characteristics and rating of converter valves and converter transformers (MVA, tap changer range etc.) It also forms the input for AC Filter and Reactive compensation design. The main circuit arrangement and circuit shall depend on type of HVDC system, Power Transmission requirements, DC Voltage Levels, connected AC voltage levels, Reactive Power requirements and AC and DC Harmonic requirements. The system shall meet various harmonic performance parameters, as specified elsewhere in this specification, on both AC Side and DC side. This requirement along with those given in Table-2, shall be met simultaneously by the AC/DC filters.

17. HVDC Station Equipment

The function blocks of converter station are Converter area (converter valves, converter transformer, smoothing reactor(if required)), DC yard (DC filters (if required), DCCT, DC Voltage Divider, PLC filters of DC side (if required), DC pole arresters, Disconnectors and ground switches), AC filter yard (as per design requirement), AC yard and auxiliaries. A typical VSC based HVDC station shall consist of the following main equipment:

- (a) IGBT/BIGT valves and its accessories e.g. damping and grading circuits, converter cooling system etc.;
- (b) Converter transformers;
- (c) Arm Reactors/Phase reactors
- (d) Smoothing reactors (if required);
- (e) DC filters; (if required);
- (f) AC filters (Harmonic filters and PLC filters) and shunt compensation; (if required);
- (g) Control and protection of AC and DC side;
- (h) Electrical and mechanical auxiliaries;
- (i) Dedicated Metallic Return (DMR);
- (j) AC switchyard equipment;
- (k) DC switchyard equipment;
- (l) AC and DC Surge arresters;
- (m) AC and DC Measuring instruments;
- (n) Communication system between converter stations (OPGW)
- (o) DC wall bushings
- (p) AC wall bushings (if applicable)

Transmission Service Agreement

- (q) Auxiliary Power System
- (r) Key interlocking system for valve hall, DC filters (if applicable), AC filter (if applicable)
- (s) Fundamental frequency blocking filter, if required
- (t) Pre -insertion resistors with bypass breaker for charging of converter module capacitors.
- (u) High speed DC discharge switch and resistor to allow fast DC line fault discharge if required for fast dc line fault recovery.

18. Converter Station AC Yard, Transformer yard and valve hall

(a) AC commutating bus equipment

The AC circuit breakers, disconnectors, instrument transformers and other switchyard equipment shall be similar to that of the equipment specified under Regulation 46 of Central Electricity Authority (Technical Standards for Construction of Electrical Plants and Electric Lines) Regulations, 2022. The bus rating shall be adopted according to the calculation considering single bus outage. The switching duties of the AC circuit breakers will be decided based on transient over voltage study, insulation co-ordination, AC filters and protection studies.

Insertion resistors:

Insertion resistors shall be used to limit inrush currents during energization of the converter. They shall be located on the primary or converter side of the converter transformer. After the energization process is completed, the resistor shall be bypassed by a disconnector or bypass switch.

(b) AC harmonic filters and shunt compensation, if required

State-of-the-art Voltage-Sourced Converters (VSC) in modular multi-level converter (MMC) topologies generate nearly no or only a small amount of harmonics. The need of ac harmonic filters shall be evaluated based on study results. Suitable redundancy shall be provided in the filters to avoid reduction of transmission capacity of the station due to outage of any particular sub-bank for maintenance.

The AC harmonic filters shall be switched in and out by circuit breakers in FIFO logic to increase lifetime of switchgear. Based on the studies, reactive power requirement for the terminal and bank or sub-bank size shall be determined such that reactive power exchange with the AC bus shall remain within specified limits.

System Contribution:

Transmission Service Agreement

Bidder may suitably model nearby different RE generators as all these generators are required to meet harmonics requirement under "CEA Technical standards for Connectivity to the grid" regulations.

At Converter station ac bus, combined converter and static compensator (if used) harmonic currents as calculated for rating purposes shall be increased to allow for harmonic currents from the ac system (*if applicable*) in following manner:

- a) At 3rd and 5th Harmonics the increase in current to be allowed shall be calculated based on the assumption that the existing distortion shall be considered as 2% with respect to nominal voltage at converter bus. This is to be considered for 3rd and 5th harmonic Filter component rating
 - b) At all even order harmonics and at all other non-characteristic or theoretically cancelled harmonics the increase in current to be allowed shall be not less than 50 (fifty) percent provided that the contribution of the harmonic in question to any rating parameter, in the absence of the above increase, is not greater than 10 (ten) percent of the total harmonic rating.
 - c) At all characteristic harmonics or at any other harmonic which is effectively filtered (i.e. the harmonic contributes more than 10% of the total harmonic rating of a component in the absence of the increase) the increase in current to be allowed shall not be below 20 (twenty) percent.
- (c)** If filters are required, the main filter equipment namely capacitors, reactors and resistors shall comply with the requirements of following IEC or Equivalent IS as follows:
- A. Capacitors-IEC 60871;
 - B. Reactors - IEC 60076-6;
 - C. Resistors - IEC 62001/As per owner's specification.
 - D. Only air-core reactors shall be used in AC and DC filters for harmonic filtration.
- (d)** If study results confirm the need for power line carrier (PLC) filtering, PLC filters shall be installed close to converter transformers to mitigate high frequency harmonic currents generated during IGBT/BIGT switching.

Performance Requirement

The AC harmonic performance shall be better or equal to as defined by following performance parameters:

Transmission Service Agreement

- A. The individual harmonic distortion, D_n , shall not exceed 1.5%
Individual Harmonic Distortion, $D_n = V_n/V_1$
- B. The Telephone Influence Factor (TIF) shall not exceed 50.
Telephone Influence Factor, $TIF = \sqrt{\sum (V_n * F_n / V_1)^2}$

Where F_n : Weighting factor for nth harmonic according to EEI publication - 60-68(1960) corrected to 50 Hz operation by graphical interpolation

- C. The Total Effective Distortion, D_{eff} , as defined below shall not exceed 3%:

$$D_{eff} = \sqrt{\sum_{n=2}^{n=50} \frac{V_n^2}{V_1^2}} \times 100$$

'1' refers to fundamental frequency (50 Hz)

'n' refers to the harmonic of nth order (corresponding frequency is 50 x n Hz)

The active impedance presented by VSC HVDC at AC bus shall have no undamped or negative impedance region for all harmonics included inter harmonic based on IEC 62001-5, clause 9.2 and 9.3. In case, certain network harmonic impedance cannot be addressed by VSC HVDC, required solution should be included.

The performance of the AC harmonic shall be determined by calculation and shall be based on either as-tested parameters of components or the extreme values of manufacturing tolerances if as-tested values are not available. Performance requirements are to be met for all operating modes. In all Modes of operation, except the reduced DC line voltage modes, the performance requirement shall be met up to rated power with one larger size filter sub-bank and one characteristic harmonic sub-bank (largest) being out of service. All filter banks, sub-banks and branches shall be rated such that the remaining filter components are not overloaded due to detuning or resonance within the filters or between the filters, the generators, and the AC system for any combination of AC system voltage and/or frequency and configuration, or for any operating condition of the converters, or combination thereof, for which the converter valves are capable of continuous operation, or switching time between de-energized and energized states and there is no restriction on the operating power level for any operating conditions with one filter bank outage for power level up to 1.0 p.u. Short-time and transient conditions as well as operation with discontinuous DC current must be fully taken into account.

(e) Shunt Reactor Banks

Transmission Service Agreement

Shunt reactors, if required, of suitable size shall be provided to meet reactive power exchange requirements derived from the studies. The shunt reactor must be switched in or out by a circuit breaker. The shunt reactor shall conform to CEA's Standard Specifications and Technical Parameters for Transformers and Reactors (66 kV and above voltage class). The shunt reactor shall be covered under automatic switching under the reactive power control strategy.

(f) Converter transformers

- (i) The converter transformer shall be designed in accordance with IEC- 60076-57-129. The converter transformers shall be single phase two winding units. The maximum flux density in any part of the core and yoke at the rated MVA, voltage and frequency shall be such that under 10% continuous over voltage condition it does not exceed 1.9 Tesla. The Converter transformer shall be capable of withstanding minimum DC current of 10 A per single phase transformer entering through the neutral.
- (ii) Transformers shall withstand combined voltage and frequency fluctuations which produce the following over fluxing conditions:
 - a. 110 % for continuous
 - b. 125 % for 1 minute
 - c. 140 % for 5 seconds
- (iii) It shall be demonstrated in design that the converter transformer shall not move to saturation beyond the design limit for overvoltage magnitude and duration applicable for the project.
- (iv) The insulation level for the transformer AC (line side) windings and bushings shall be as given at Regulation 45 of Central Electricity Authority (Technical Standards for Construction of Electrical Plants and Electric Lines) Regulations, 2022 and insulation levels of the valve side windings shall be determined in accordance with studies. The impedance of the transformer shall be determined as in accordance with studies and variations in impedance shall be as per the requirement of relevant standards.
- (v) Converter transformers shall be equipped with On Load Tap Changer (OLTC) and Metal Oxide Varistor (MOV) devices shall be provided between tap leads of the OLTC. The OLTC tap steps shall be determined in accordance with the operating strategy of both the converters. The OLTC shall be designed for a minimum 2,50,000 operations without repair or change of any part including oil. The OLTC shall be designed for a contact life of minimum 6,00,000 operations.
- (vi) The requirements of soak pits and firewalls shall be in line with Regulation 46 of Central Electricity Authority (Technical Standards for Construction of Electrical Plants

and Electric Lines) Regulations, 2022.

- (vii) The converter transformer bushing shall be designed in accordance with IEC-60137/ IEC-65700, as applicable.

19. Converter valves and valve cooling system

- (a) The converter valve assembly shall be designed and tested as per relevant IEC 62501. The valve shall be designed and protected during operating conditions for various over voltage and over current stresses to which it may be subjected to due to faults occurring in various parts of the station.
- (b) The converter valve modules, used for converting AC to DC or vice versa, shall be complete with associated electronic IGBT switching system; protection, monitoring and damping system, auxiliaries and cooling system. Adequate redundant devices shall be provided to enable continued operation in case of failure of an individual component. Advanced converter topologies shall be used to reduce losses of VSC based HVDC converters.
- (c) The IGBT power modules shall be water cooled, air insulated and indoor type. The valves shall be either suspended type or floor mounted type depending upon the operating DC voltage and seismic requirements.
- (d) Necessary control and monitoring including tripping of the HVDC system in case of cooling system failure shall be provided.
- (e) The valves shall be placed in the valve hall which shall have a positive pressure over atmospheric pressure and humidity control feature through HVAC system.
- (f) No oil immersed part is permitted to be used inside the valve as well as valve hall. The electronic components located within the valve shall be designed to eliminate overheat and arcing. Only components of low flammability, high reliability and adequate ratings in margins can be used.
- (g) **Description of Valve Cooling System:**
 - (i) **Fine Water Circuit**

The fine water circuit shall consist of a main circuit and a water treatment circuit. The cooling medium in the fine water circuit shall be deionised water with low conductivity.
 - (ii) **Main Water Circuit**

The main cooling circuit shall consist of water within the converter valves, a de-aeration vessel /venting, pumps and filters.
The main circuit shall be provided with an expansion vessel with level

Transmission Service Agreement

transducers and or pressurised with nitrogen, as per requirement of OEM design. The level transducers shall be used for control of the make-up water for the system, if applicable, and for detection of leakages.

There shall be two water pumps. One of the two water pumps shall circulate the 100% water through the main cooling circuit and the water treatment circuit. The other pump shall be included for redundancy purpose. The operation shall be automated and arranged into alternative weeks between these two pumps. Upon failure of the unit in service, the redundant shall be automatically activated.

(iii) Water Treatment Circuit

A part of the main flow shall be circulated in the water treatment circuit. The water treatment circuit shall consist of oxygen removers (if required), ion exchangers and mechanical filter. Sensors shall be provided for measuring conductivity of the water, both in the main cooling circuit and in the treatment circuit at the exit side of the ion-exchanger. The water treatment circuit shall have provision to connect makeup pump and associated valves and strainers. The water pipe for fine water make up shall be connected to main fine water circuit through the water treatment circuit.

(iv) Air Cooled Liquid Coolers

The air-cooled dry type liquid coolers shall cool the water from the converter valves. At least one cooler unit or minimum 10% of total cooler units required to achieve the operating water temperatures for rated power (whichever is more), shall be provided by the TSP as redundant over and above the quantity required.

All the stations shall have dry type coolers. Each cooler shall consist of cooling fans with separated air channels.

Suitable protection against corrosion, oxidation etc. shall be provided for all cooling equipment.

(v) Mechanical Design

The cooling system shall be pre-fabricated. There shall be three main parts:

- fine water pump unit;
- air cooled liquid coolers;
- piping.

The fine water pump unit shall be mounted on a frame and shall be placed in the valve cooling room. The air-cooled liquid coolers shall be placed outdoors, near to the valve cooling rooms. The piping shall be especially designed stainless steel and adapted to the station building.

(vi) Control Equipment

Transmission Service Agreement

The valve cooling control equipment shall be specially designed for application to the cooling system for converter valves. There shall be two computer-based control systems such that either both are in ACTIVE mode, or when one system is in ACTIVE mode the other system shall be in ACTIVE STANDBY mode. Each computer-based system shall be self-checking and an automatic changeover to the other system shall take place in the case of failure of the active system.

(vii) Design Criteria for the Cooling System

Features to ensure high reliability, proper function and prolonged life time for the cooling system and converter valves shall be included. The following main components shall be supplied with redundancy in order to increase the availability:

- main circulation water pump
- air cooled liquid cooler (with redundant cooler as provided in (iv) above)
- bypass valves
- transducers
- nitrogen bottles, if applicable

(viii) Design Cooling Requirements

Separate cooling system shall be designed to cool the heat generated in each monopole for converter stations.

Cooling system shall be capable to operate and guarantee the design temperature specified under steady state conditions, up to max specified design dry bulb ambient temperature. Redundant Uninterrupted Power System/drive for valve cooling for each pole shall be rated for 2 minutes.

(ix) Ambient conditions

Ambient Conditions are specified in Table 2 of the specification.

(x) Materials

The materials in contact with the cooling water as well as for manufacturing of the air-cooled liquid cooler shall be selected in order to minimize the risk of corrosion.

(xi) Measure Against Water Leakage

The design of the valve cooling system shall be made to minimise leakages. The following precautions shall be taken to minimize the risk of water leakage from the system:

- choice of water pipe joint
- number of water pipe joints in the system shall be kept as low as possible, particularly in the IGBT based converter ;
- velocity of de-ionized water in the pipes and in the IGBT based converter

Transmission Service Agreement

submodules heat sinks shall be kept low

- water circulation within the pipes shall be free from trapped air bubbles

(xii) Valve Cooling Control and Monitoring

The valve cooling control systems shall be redundant and be equipped with an integrated data collecting unit that is connected to the station sequential event recorder system.

(xiii) Cooling Capacity Control

The water temperature to and from the Converter/IGBT valves are used as an input to the cooling capacity control.

In order to avoid condensation at the pipe lines within the Converter/IGBT valves the inlet fine water temperature shall be kept in an appropriate range.

(xiv) Protections

The following protections/monitoring shall be included:

- Temperature of the water from the valves
- Temperature of the water to the valves
- Water flow through the valves
- Water level in the expansion vessel
- Conductivity of the water from the water processing unit
- Conductivity of the water in the main circuit
- Pressure in the expansion vessel, if required
- Pressure in the nitrogen bottle, if required.

(xv) Leakage Detection

There shall be three leakage detection methods used in parallel by the cooling control system. These methods can, depending on the nature of the leakage, generate trip of the converter and cooling system. However, one of the methods of leakage detection shall generate a leakage alarm if volume of leakage exceeds the reference volume, during the last 24 hours.

Besides these detection methods alarms for frequent make up and for long make up when automatic make-up of cooling water is used, generated by the cooling control program shall be provided. The total schematic of valve cooling system with valve position, flow, temperature, make up details, conductivity, pump running etc. shall be made available to the SCADA system of HVDC terminal.

20. Converter Station DC Outdoor Yard

Transmission Service Agreement

- (a) The DC yard shall comprise of equipment such as HVDC bushings, smoothing reactors (if required), DC filters (as required), DC current and voltage measuring instruments and switchgear, surge arrester, insulators, clamps and connectors.
- (b) The specific creepage distance (corresponding to highest DC voltage) for DC yard and other areas shall be maintained as follows:

Table 6

Insulator type	Under light and medium pollution	Under heavy and very heavy pollution
Indoor porcelain or composite insulators for valve hall (other than valves) and indoor smoothing reactor area (if any)	20 mm/ kV	
IGBT Valves	14 mm/ kV	
Outdoor porcelain insulators or bushings with RTV# coating	50 mm/ kV	60 mm/KV
Outdoor composite insulators or bushings	50 mm/ kV	

RTV silicon coating shall be in accordance with IS 11310.

Note: Specific creepage distances less than 50 mm/ kV but not less than 45mm/ kV can be accepted for outdoor silicone rubber bushings due to manufacturing limitations and for HVDC equipment requiring necessary internal/ external insulation co-ordination. However, specific creepage distance less than 50 mm/kV and flash distance less than 12 mm/kV shall not be acceptable for outdoor jointed bushing.

(c) DC wall bushing

DC wall bushing shall be designed as per IEC-65700. DC wall bushings, used for electrical connection between the equipment inside the valve hall and the outdoor DC yard shall be of polymer housing as per relevant standards. All bushings inside the valve hall including HVDC wall bushing shall be dry type/SF₆ gas filled or combination of both. There shall be no oil filled components inside valve hall.

(d) DC reactors

The smoothing reactor/Arm reactor/phase reactor/ DC filter reactor (as applicable) shall be designed as per IEC-60076-6. The reactors shall be of air core type. The reactors shall comply with relevant standards and shall have successfully passed DC

Transmission Service Agreement

tests as per their application. Each converter station shall be provided with one spare coil of each reactor with all fitments, hardware and accessories. Minimum four Nos. of insulators of each type for reactors shall be provided as spare.

The reactor shall be designed for Class H for inter turn insulation as per IEC 60085, however, the maximum allowed hot-spot temperature rise shall be limited to one class lower i.e. Class F insulation.

(e) **DC Voltage and Current Measuring Devices**

The DC voltage and DC Current measuring equipment shall be installed at each pole. These equipment can be optical type or conventional type. The DC measuring equipment at pole and neutral bus shall be suitably located based on the control philosophy and different protection zones such that complete pole and neutral equipment are protected. The details of DC Measuring Equipment shall be as per '**Appendix C.1**'.

(f) **DC Filters (if required)**

Suitable numbers of DC filter per pole per station shall be provided in DC yard to limit harmonic voltages present on the DC lines (pole lines and DMR line) as required by HVDC OEM design.

The design shall be based on passive DC filters. The DC Filters shall consist of Low order filters, Harmonic Filters and High Frequency Filters as per the requirement of project specific studies. The main filter equipment like capacitors, reactors and resistors shall comply with the requirements of relevant IS/IEC standards/ CIGRE documents. A fundamental frequency series blocking filter shall be provided, as per requirement. The required switches shall be provided. It shall be possible to connect and isolate a single DC filter arm without causing any reduction in transmitted power on the affected Pole.

The calculation of DC filter performance and rating shall be based on values of components, detuning, and harmonic voltages and currents. The TSP shall use model as per CIGRE TB 766 and 811 or equivalent for calculating performance and rating of DC filters.

There shall be no limitation on the energization of the DC filter arms by reason of either ambient temperature, frequency, initial mistuning or DC voltage within the ranges defined in this Specification. The DC filter components shall not become overloaded due to detuning or resonance within the DC filter or between the DC filter arms and the HVDC circuit, or the DMR, for any combination of conditions for which the converters are capable of continued operation.

TSP shall ensure that fundamental and 2nd harmonic resonance and adverse amplification does not occur on DC side. A parallel low order (2nd Harmonic) DC Filter

shall be provided across each converter of each station. Earth resistivity along the DC line route will be considered as 250 ohm-m.

DC filter Performance:

The individual harmonic current (I_n) at any harmonic shall not exceed the value which could cause mal-operation of the HVDC system control and protection equipment supplied. The maximum equivalent disturbing current (I_{eq}), up to rated power in forward power direction, without any filter outage, for balanced bipolar and monopolar mode with metallic return or Dedicated Metallic Return (DMR) modes of operation shall be as follows:

Table 7

Operating Mode	I_{eq}
Balanced bipolar operation	1500 mA
Monopolar mode with metallic or DMR mode	2200 mA

The equivalent disturbing current includes not only the harmonics which flow in the DC Pole conductors and DMR lines but also the harmonics which are induced into the ground wires of the DC transmission line.

Mutual impedance calculation algorithms require that the ground wires be “eliminated” for this configuration; however, as specified herein, the current flow in the ground wires must be eventually taken into account in the calculation of equivalent disturbing current.

In Bipolar operation, the equivalent disturbing current shall be the psophometric weighted residual current of all harmonics of fundamental frequency from the 2nd to the 60th (i.e. 100-3000 Hz) according to the following formula:

$$I_{eq}(x) = \sqrt{[I_{eC}(x)^2 + I_{eS}(x)^2]}$$

Where,

$I_{eq}(x)$ is the equivalent disturbing current in milliamps (mA) psophometrically weighted at any point along the transmission corridors specified herein

$I_{eC}(x)$ is the magnitude of the RSS equivalent disturbing current component due to harmonic voltage sources at Khavda (mA)

$I_{eS}(x)$ is the magnitude of the RSS equivalent disturbing current component due to harmonic voltage sources at South Olpad Converter Station (mA)

x denotes the relative location along the transmission corridors.

Transmission Service Agreement

The equivalent disturbing current at any point along the corridor due to harmonics from either Khavda or South Olpad Converter Stations shall be calculated as follows:

$$Ie(x) = \sqrt{\sum_{n=1}^{n=60} \{Ir(n, x) * P(n) * Hf\}^2}$$

Where,

$I_r(n, x)$ is the magnitude of the equivalent residual rms current at each harmonic in milliamps.

(n) is the psophometric weighting at harmonic "n" as per Consultative Committee for International Telephony and Telegraphy (CCITT)

n denotes the harmonic number.

Hf is the coupling factor which represents the normalized frequency dependent effects of typical coupling impedances to open wire circuits. The coupling factor Hf will be assumed as per table below:

Table 8

Frequency (Hz)	Coupling Factor (Hf)
40-500	0.70
600	0.80
800	1.00
1200	1.30
1800	1.75
2400	2.15
3000	2.55
3600	2.80

As defined above, all harmonics up to the 60th shall be included in the calculation of equivalent disturbing current. The equivalent disturbing current shall be based on a "worst consistent set" of harmonic voltages at either end of the line.

The "worst consistent set" is defined as that set of harmonic driving voltages which could occur at any particular operating condition which results in the highest value of equivalent disturbing current that could occur for a period of longer than ten minutes.

A particular operating condition is defined in terms of:

- a) The mode of operation, i.e. bipolar or monopolar in any specified mode of operation.
- b) The DC voltage anywhere within the normal range for the mode of operation.

Transmission Service Agreement

- c) Reduced DC voltage operation on both Poles and reduced DC voltage on one Pole with the other Pole at nominal DC voltage.
- d) The modulation index anywhere within the range applicable to the mode of operation as defined above which shall include modulation index associated with reactive power control.
- e) Worst case induced voltage from any parallel lines.
- f) The converter AC bus voltages anywhere within the normal range specified.
- g) The maximum 50Hz negative phase sequence voltage of 1.5% for achievement of performance limits.
- h) The DC current anywhere within the range applicable to the mode of operation.
- i) Ambient temperature as defined in Table 2.
- j) Differences in the smoothing reactor (if installed) harmonic impedances of the Poles

DC filter rating

The rating of the DC filter components shall be based on the assumption that the per pole harmonic voltage is individually maximized at each harmonic for any particular operating mode, and the filter component currents due to the harmonic voltages at the terminals shall be assumed to add as RSS (Root Sum Squared) at each harmonic.

For the rating of the DC filter components, it shall be assumed that any one DC filter arm can be out of service in any converter Pole. The possible impact of reduced voltage operation and increased reactive absorption on the ratings of the DC filters shall also be considered.

Short time and transient conditions as well as operation with discontinuous DC current must be fully taken into account. Due allowances shall be made for possible current amplification resulting from resonances between the arms of the DC filters. In the calculation of the impedance of the DC transmission system when used for calculation of DC filter component rating, $\pm 10\%$ tolerance in the respective line length shall be included. AC system voltage and frequency variations as functions of duration specified in Table 2 shall be allowed in the calculation of harmonic voltages and DC filter detuning. In addition, capacitor unit or element failures appropriate to the duration for which the DC filter has to remain connected, shall be allowed for in the calculation of DC filter detuning.

(g) **Surge Arrester**

Surge arresters shall be gapless Metal Oxide arresters and shall be designed and tested as per relevant IS/IEC. The arresters shall be designed to absorb the desired amount of energy during a system disturbance and shall be coordinated with recovery of DC system following a disturbance as applicable. Arresters at appropriate places may be provided as per requirement.

(h) **Fundamental frequency blocking filter:**

A fundamental frequency blocking filter may be installed, if found necessary, to block the 50 Hz induced current in DC line in order to minimize the risk of converter transformer saturation due to possible induced fundamental frequency current from parallel AC lines

This induced current usually results from AC side second harmonic positive sequence voltage and from AC lines running parallel to DC line.

For design purpose, 50 km of parallel un-transposed 765 kV AC Double Circuit line and 50 km of parallel un-transposed 400 kV AC Double circuit line within a radial distance of 70 m to be considered by the TSP to consider any possible inductive and capacitive coupling between the lines. The parallel section of AC lines shall be considered to be located at a point that results in maximum fundamental frequency current at each converter station.

Such a filter is formed of capacitor, reactor, resistor and arrester. Internal arrangement of these components is left to designer but the overall filter should offer significant impedance to 50 Hz current flowing in DC circuit. Blocking filter reactor shall be designed for Class H for inter turn insulation as per IEC 60085, however, the maximum allowed hot-spot temperature rise shall be limited to one class lower i.e. Class F insulation. The reactor may preferably have similar design as smoothing reactor (if any) to share common spare. The AC/DC/PLC/RI reactor shall be designed for Class F insulation as per IEC 60085, however, the maximum allowed hot-spot temperature rise shall be limited to one class lower i.e. Class B insulation.

(i) **DC commutation switches:**

These switches are required for commutating the DC current from one path to the other. They comprise of Dedicated Metallic Return Transfer Breaker (DMRTB), Pole Metallic Return Transfer Breaker (PMRTB), Neutral Bus Grounding Switch (NBGS). These switches shall be rated for transfer of the full load current online without

converter trip or block leading to power loss. Neutral Bus Switch (NBS) shall also be provided suitably at both ends in all the poles.

21. Dedicated Metallic Return (DMR)

The neutral current return path for bipolar configuration or monopolar configuration shall be via a Dedicated Metallic Return (DMR) conductor connecting both converter terminals.

22. Control and Protection System

It shall be demonstrated that the HVDC control system is stable under all operating conditions and cannot excite oscillations, such as sub-synchronous oscillations, between the HVDC and AC system. The control system shall be tuned for optimal overall performance for all conditions and configurations of the AC system. The details of operator Control and Monitoring are mentioned in '**Appendix C.2**'.

It shall also be demonstrated, by applying system faults and step responses in current order and power order during the factory acceptance testing (FAT), that the as-built control system does not excite low order harmonic resonance(s) in the AC system and/or between HVDC and AC systems for any system configuration.

The performance of the integrated DC and AC systems shall also be demonstrated using an EMT-type program (such as PSCAD) in order to validate the system performance requirements. In the DPS program, all the HVDC protections shall be modelled. All feeders in the ac converter bus should have the required protections modelled for DPS studies with network equivalent.

DPS studies shall be done with DPS model of Khavda LCC HVDC, DPS model of Khavda Pooling station and RE Park in vicinity. DPS models shall be provided for the LCC HVDC and Khavda Pooling station including RE park shall be provided to TSP.

Software based controls and protection shall be used to permit flexibility in effecting modifications. Protection and controls shall be duplicated for reliability. The control and protection shall provide fast controllability of the HVDC system.

(a) Control System:

- (i) The control system shall have redundancy with hot standby. Transfer of controls from Active Control system to Hot standby control system shall be seamless and there shall be no power interruption during this transition. Outage of one control system or part thereof, shall not result in any power reduction.
- (ii) The control shall be designed to give fast, stable and proper response to normal control actions as well as during disturbances such as AC and DC faults.
- (iii) DC converter terminals shall be either manned by operator or controlled by remote operation of SCADA system. The control system hierarchy shall be as

Transmission Service Agreement

follows:

1. Master Control
2. Station/Bipole Control
3. Pole/ Converter Control
4. Valve Control

(iv) The HVDC Station/Bipole shall have control features including but not limited to the following:

1. AC Voltage and Reactive power control
2. DC Voltage and Active power control
3. Frequency control
4. Power modulator, pole power compensation. The modulator, if required, shall have feature which shall provide positive damping of AC network oscillations over the range of frequencies considered during system studies.
5. A. Sub Synchronous Resonance (SSR) Damping Controller (if required) based on studies.

All necessary studies shall be carried out to ensure that the DC system shall not excite the mechanical, electromechanical or other natural frequencies of the nearby region generators and turbines under any operating mode. It shall be demonstrated by studies that the nearby generators shall not be adversely affected by the HVDC system, particularly with regard to Sub Synchronous Oscillation (SSO)/Sub Synchronous Resonance (SSR) and harmonic injection and self-excitation. Sub Synchronous Damping (SSD) Controller shall be provided for converter stations near Generating stations.

B. Power Oscillation Damping (POD) Controller in STATCOM mode of operation.

6. RE Park Sub synchronous control interaction studies, Temporary and Transient overvoltage checks, harmonic interactions, stability, HVRT, LVRT etc.
7. Interaction studies among various HVDC links and STATCOMs (planned/ execution) which are electrically coupled nearby e.g. LCC based ± 800 kV, 6000 MW converter at KPS-2;; STATCOMS as per following table:

Sr. No.	Capacity of STATCOM	Name of Substation
---------	---------------------	--------------------

Transmission Service Agreement

1	±300 MVar	KPS-1 (Section-I)
2	±300 MVar	KPS-1 (Section-II)
3	±300 MVar	KPS-3 (Section-I)
4	±300 MVar	KPS-3 (Section-II)
5	±200 MVar	Boisar-II (Section-I)
6	±200 MVar	Boisar-II (Section-II)
7	±300 MVar	Navsari (New)

8. The TSP shall study all interaction aspects between these converter stations, STATCOMs and devise control strategies to ensure that no adverse interaction takes place among the above stations during steady state and fault recovery. Various fault cases for the purpose of this study shall be finalized with the employer during detailed engineering.
9. The HVDC system shall conform to the performance requirements specified herein. It shall be designed to optimally co-ordinate all aspects of its controls to ensure safe and reliable operation without adversely affecting the connected ac system and shall assist the latter following disturbances. The performance requirements shall be met under all specified ambient conditions, modes of operation, ac system conditions and other parameters as given in this specification
10. Run back/Run up controller (10 points) with provision to be linked to Special protection Scheme (SPS) of System Operator.
11. AC system stability function, such as power swing damping function.
12. Any other Controller as deemed required for stable HVDC system operation with connected AC network.

(b) Protection System

The protection system shall be designed in Main-I and Main-II set up.

- (i) HVDC system protection shall consist of two parts:

(A) AC side protection

AC side protection function shall cover the zone for converter transformer, AC filters(as applicable), shunt capacitors, shunt reactors, and busbars. These protections shall generally follow the same philosophy as in a typical AC substation i.e. detection of fault by relay and tripping of circuit breaker or may be dealt in similar way as described for DC side protection.

(B) DC side protection

Transmission Service Agreement

DC side protection shall cover the zones consisting of HVDC AC PLC Area to Converter transformer Primary, Converter Transformer, Area between converter transformer, Phase reactor and the valve hall, Converter Protection Zone, DC Bus bar Protection Zone, DC switchyard including smoothing reactor (if applicable) and DC filters (as applicable), DC line, and DMR line. The protection equipment shall be designed to be fail safe and shall ensure high security to avoid mal-operation/ unwanted shutdown due to protection equipment failures. 'Main-I and Main-II' or 'Main and Standby' protection philosophy shall be adopted for HVDC equipment and system.

- (ii) Following a DC Line fault, the HVDC System shall have the facility to restart. The DC transmission system shall be capable of recovery in a controlled and stable manner during recovery following AC and DC system faults. The post fault power order shall be equal to the pre-fault power order unless AC/ DC systems dictate otherwise.
- (iii) Protection system shall have two redundant systems with following protections (Some protection can be combined).
 - a) Converter differential protection
 - b) Converter Protection
 - c) AC, DC over current/under current protection
 - d) AC, Overload Protection.
 - e) AC, DC bus differential protection
 - f) AC conductor ground fault protection
 - g) DC filter protection, if applicable
 - h) Converter transformer valve winding protection
 - i) DC line differential protection
 - j) DC under voltage/ over voltage protection
 - k) DC line ground fault protection with restarts
 - l) High Impedance DC ground fault Protection
 - m) Harmonic Protection on AC side and DC side.
 - n) Negative Sequence Protection.
 - o) Phase current unbalance.
 - p) Dedicated Metallic Return (DMR) protection
 - q) DMR monitoring
 - r) AC filter protections, as applicable
 - s) Protection Block Failure or Repetitive Blocking failure protection
 - t) Converter arm harmonic protection
 - u) DC Line Overcurrent Protection

Transmission Service Agreement

- v) DC Line harmonic protection
- w) Power module failure monitoring
- x) SSTI Protection (corresponding to POWER Plants)
- y) SSDC Control Interaction Protection. (Corresponding to RE Plants).

Other Protections required for successful operation of VSC HVDC with HVDC LCC and RE Park in vicinity like transfer trips to RE Park 400 kV bus and LCC HVDC Converter. Provision for transfer Trip options shall be available in TSP's own Protection panels in digital and analog hardware form. Necessary assistance for integrating with OPGW shall also be included.

23. DC Line fault locator

DC online fault locators shall be provided to monitor the entire DC line length and give location of the fault with good accuracy in the range of + 1000 meters for pole conductors. DC line Fault Locators shall utilize a method of measurement of time of arrival at each end of the HVDC line of the steep wave fronts, resulting from a fault on the HVDC, affected by the accuracy of the time measurements. Since the wave fronts shall propagate along the lines at 3×10^8 m/sec (or 300 metres per microsecond), the time measurements must be in microseconds with an accuracy of ± 3 microseconds in order to achieve a location accuracy of approximately ± 1 km. Greater precision of fault location would be desirable. The DC online Fault Locator equipment at each station shall be time synchronized to the master clock system at the station in order to facilitate analysis of system disturbances recorded on the DC Line Fault Locators, the transient fault recorders and the alarm monitoring and recording system. Manually re-settable fault counter shall be provided as part of the equipment.

ELECTRIC CHARACTERISTICS

1) Control Panels

Identical control panels shall be provided for each DC Line Fault Locator within its own cubicle(s). The control panel shall include, but not be limited to the following facilities.

- Equipment on/ off control and indication;
- Equipment alarm or failure indications;
- Fault location readout display for the last detected line fault;
- Manual initiation of automatic self-test routines;
- Any other controls or indications

2) Printers

Transmission Service Agreement

A printer shall be provided for each DC Line Fault Locator or it may be integrated with operator control and monitoring system. The printer shall print the day, hour, minute, second and millisecond of each fault or manual or automatic system test. The printer shall also print the location of each fault in kilometres from the respective station.

If fault locator is integrated with operator control and monitoring system that all these details shall be displayed on Video Display Unit (VDU) and stored in archives in the backup memory.

3) Power Requirements

The equipment shall be suitable for operation from the station battery supply. There shall be no loss of accuracy within specified variations of DC input voltage.

Note: Alternatively, TSP may also propose an integrated solution with the fault locator integrated into the HVDC Control and Protection system meeting the system requirements. If fault locator is integrated with operator control and monitoring system then all these details shall be displayed on Video Display Unit (VDU) and stored in archives in the backup memory.

24. Operations supervision and control

- a) The TSP shall provide the control facilities from the operator control desk through a monitor and keyboard/mouse system. These facilities shall include all control operations, digital setting, indicating devices, Station single line diagram and symbols, any other special control devices and meters required for control and monitoring of the complete HVDC system.
- b) The layout of the station single line diagram, together with control, indicating and metering devices on the control desk shall be logical, compact, of pleasing appearance, and shall facilitate efficient supervision and operation of the station(s) by the operator. Every detected change of position shall immediately be displayed in the single-line diagram on the station screen, recorded in the event list and printable.
- c) Graphic representation of Converter valves and valve cooling piping network shall be provided on station monitoring system. The graphical representation shall also display indicating faulty valve submodules position.
- d) The 'Sequence of events' recorder, transient fault recorder, on-line DC Line fault locator, GPS system, Station Master Clock, visual display system, operator control protection and monitoring system shall be a part of the HVDC system.

The details of operator control and monitoring system are provided at 'Annexure-

Operator Control and Monitoring System'. The Transient Fault Recorder provided for the HVDC system shall be as per '**Appendix C.3**'

25. Telecommunication

For smooth operation of the HVDC system, communication network with high reliability and availability shall be provided for transmission of control and protection signals between the two or more (in case of multi-terminal DC) HVDC terminals. The communication system design shall be as per '**Annexure- Specific Technical Requirements for communication**'.

A limited remote data transfer of the HVDC system from the Load dispatch centers shall be provided by TSP. All required remote control and remote monitoring facilities shall be provided at each converter station. Complete remote monitoring of each converter station shall be possible from opposite converter station.

Synchro phasor measurement using Phasor Measurement Units (PMUs) along with fibre optic connectivity, Global Positioning System Receiver and communication equipment shall be provided for monitoring AC side of converter bays of HVDC station.

26. Valve Hall

The valve hall shall mainly contain BIGT/IGBT valve, its associated structure, cooling and arresters. No oil filled equipment shall be present inside the valve hall. In case the turret of converter transformers (having oil) is protruding inside the valve hall, suitable fire barrier matching with adjacent valve hall wall fire rating shall be provided. The valve halls shall be provided with interference screening, if required by OEM. In addition, the control cable and cable termination rooms shall be suitably screened to minimize radio interference. Necessary measures shall be taken to take care of high frequency noise emission from valves.

The valve halls shall have ample clearances such that the inspection of valves can be possible and allow access of mobile valve servicing equipment without any dismantling. The valve hall building shall be pressurized to prevent the ingress of unfiltered air. In addition, the building shall be properly sealed to minimize the flow of outside air into it and vice versa. Openings for equipment and services shall be weather proof. The Valve Hall building shall consist of steel framed structure. The steel building shall be pre-engineered building fabricated in the factory and shall be assembled at site. Minimum two Nos. scissor lift for erection and maintenance of valve modules shall be provided per station. Proper cable sealing shall be provided for cable entry into valve hall and control room to avoid entry of water and moisture.

27. Ventilation System and air conditioning for Valve Hall

Transmission Service Agreement

Each valve hall shall have an independent ventilation and/or air conditioning system. Each ventilation systems shall consist of two 100% capacity systems, one operating and one stand-by.

The ventilation of the valve hall shall be of a positive pressure type. Once through ventilation system will not be acceptable. The ventilation system shall be a closed cycle with fresh air intake limited to a maximum of 20% of the total air requirement. Fresh outdoor air shall be filtered and dehydrated before being blown into the valve hall by the air fans to avoid dust accumulation and condensation on components present in the valve hall. Suitable measures shall be taken to minimise stagnant air. Each valve hall shall be provided with remotely operated motorized exhaust dampers which shall be normally closed and will be opened under high pressure/emergency conditions only.

Air-conditioning of valve hall for reducing the operating temperature of Converters may be used if required. Airconditioning units will be provided with minimum one redundant unit (atleast 25% capacity).

To ensure that the air being supplied to the valve hall is free from dust particles, a minimum three stage dust filtration process shall be supplied. This shall consist of at least the following:

1. Pre-Filters: To remove dust particles down to 10 microns in size with at least 95% efficiency.
2. Fine Filters: To remove dust particles down to 5 microns in size with at least 99% efficiency.
3. Absolute Filters: To remove dust particles down to 0.3 microns in size with at least 99.5% efficiency.

All the filters shall be panel type. Easy access should be available to the filters for replacement/cleaning.

It shall be possible to maintain specified conditions continuously inside the valve hall, both automatically and manually controllable from the station service panel (located in the control room) as well as from the local control panel.

In addition to the alarms for particular parameters like pressure, temperature and relative humidity etc., indicating instruments shall be provided for each valve hall. These parameters shall be integrated with station monitoring system also.

The valve hall shall be kept at a pressure above the atmospheric pressure under all conditions. The test shall be conducted at site to measure the pressure inside the valve hall for 48 hours.

Adequate numbers of de-humidifiers shall be provided for each valve hall as per design requirement.

28. Air Conditioning System

Air conditioning shall be provided on a continuous basis in the control room, bay kiosks, valve module workshop and storage rooms, control and protection workshops, offices, first aid room, conference room, entrance halls, corridors etc. and all rooms containing electronic equipment.

The air conditioning system for the control room shall consist of two (2) systems each of 100% capacity; one operating and one stand-by. Both units shall be interconnected so that, in the event of breakdown of one unit, the stand-by unit can be placed into service. Stand-by and operating units shall be alternated monthly for regular operation. The operation of the units shall be automatically controlled including sequential start and stop with single command.

If valve base electronics and/or valve cooling control cubicles are located at places other than in the station control room, these areas can be cooled by using split Air Conditioning units of appropriate capacity. At least two units shall be provided, one operating and one stand-by with the facility of automatic changeover after operator assigned time period.

A separate air conditioning system shall be provided for other areas of the service building. This shall also consist of two (2) Nos. each of 100% capacity; one operating and one stand-by.

29. Visual monitoring system (VMS) for watch and ward of station premises:

Visual monitoring system for effective watch and ward of substation premises shall cover all the transformers and reactors, outdoor DC yard, valve halls, indoor and outdoor isolators, earth switches, breakers, AC and DC capacitors, all other major AC Equipment (such as CB, isolators, CT, CVT, SA etc. as applicable), panel room, all entrance doors for the service building, other buildings, all the gates of switchyard and all entry and exit points of control room building and accordingly the location of cameras shall be decided. The camera shall be high definition colour CCD camera with night vision feature. The VMS data partly/completely shall be recorded (minimum for 30 days) at least @25fps (or better) and stored on network video recorder and followed by transfer of the data to a juke box. The system shall use video signals from various cameras installed at different locations, process them for viewing on workstations/monitors in the control room and simultaneously record all the cameras. The operation of cameras shall be integrated with the Network server placed in Control room of HVDC station. Sensors shall also be placed on boundary walls to prevent intrusion from outside and shall be connected to the CCTV system. The VMS data should go only to the intended personnel/ facility and not to the remote server of the Camera (VMS supplier)

Mouse/ keyboard controllers shall be used for pan, tilt, zoom and other functions of the desired camera. The Visual Monitoring System shall have provision of WAN connectivity for remote monitoring.

Transmission Service Agreement

All camera recordings shall have Camera ID and location/area of recording as well as date/time stamp. The equipment should generally conform to Electromagnetic compatibility requirement for outdoor equipment in EHV substation.

At existing HVAC substations, the visual monitoring system if available shall be augmented as per existing or better specification as required.

30. Building Management System

A fully computerized and automatic Building Management System (BMS) shall control the operation of the mechanical systems serving the valve hall and service building and other systems as detailed below.

Scope of Work

The scope of work shall cover all necessary system provisions (including hardware and software) for synchronizing/integrating the BMS with the control and monitoring of

- Air Conditioning system,
- Valve hall ventilation and air conditioning system
- Fire Fighting Systems including Fire Spray and Hydrant systems, water level in Fire Water Tanks etc.
- Utility Services i.e. Water Storage and Supply,
- Access Control including Motorised Gate at the entrance to the station and for all entrance doors for the control room building including provision of electromagnetic door locks, card readers etc.
- Fire Detection and Alarm System.
- Illumination systems
- VMS

31. Water Supply and Distribution System

The water supply and distribution system shall include the supply, distribution and storage of water in the HVDC Station at least the following purposes.

- a) storage of water for the firefighting system;
- b) storage of water sufficient for 24 hours of continuous operation of HVDC converter in the event of interruption of water supply to the tanks;
- c) water supply for the valve cooling system;
- d) water supply for sanitary services;

Transmission Service Agreement

Two Nos. 100% capacity water storage RCC tanks shall be provided. Each tank shall be constructed in such a way that there shall be segregation between requirement for fire water storage and water for other purposes such that fire water is not used for other purpose. Both the tanks shall have interconnection piping with isolation valves for both tanks. Separate piping as per IS/IEC standard for firefighting, valve cooling and other purposes shall be provided from the tanks from independent headers.

32. Grounding and Safety:

- a) The design of the grounding system shall be based on relevant IS/IEC/IEEE standards.
- b) In order to prevent adverse effect (i.e. overheating due to induced circulating current) of magnetic field of air core reactors, special care shall be taken e.g. no closed loops are formed by the earthing conductors and in reinforcement bars of the foundation or other necessary mitigation measure to be provided. Air core reactor manufacturer's guidelines shall be followed.
- c) The electrical safety clearances for the DC side shall not be less than the clearances applicable for an AC switchyard at the equivalent BIL level.
- d) The total electric field at ground level shall be as prescribed in relevant standards.
- e) Fencing and electrical interlocking and mechanical key arrangements shall be provided for all non-accessible areas, for valve halls, and for areas where for equipment mounted directly on ground without suitable height of steel structure, e.g. smoothing reactor area, AC and DC filter areas, as applicable.
- f) Safety precautions in regards to gas/oil pipe lines in vicinity of HVDC/ AC lines shall be taken coordination with gas/ petroleum authorities.

33. Cables:

All cables shall be FRLSH type. The High Voltage (6.6 kV to 33 kV) power cables shall be XLPE insulated conforming to IS-7098 Part-2. The Low Voltage power cables shall be 1.1 kV XLPE insulated conforming to IS-7098 Part 1 or relevant IEC standards and/or PVC insulated conforming to IS-1554 Part 1. The control cables shall be 1.1 kV PVC insulated conforming to IS-1554 Part-1. The rating and size of cables shall be determined by TSP. All cables shall be armored except cables used for special purpose as per OEM recommendation. Fibre optic cables conforming to IEC- 60793 and 60794 shall be used to transmit the signals to and from various equipment and panels located in the AC/DC switchyards, Valve Halls,

control rooms, valve cooling rooms etc.

34. Auxiliary Power Supply System:

The auxiliary power supply system shall have the following:

- a) Highly reliable duplicated supply sources from two separate sources with automatic change-over facilities. These sources of auxiliary power shall be from 33 kV side of 2 Nos. of 400/33 kV transformers (50 MVA) at KPS3 HVDC and 33 kV tertiary of existing 2 Nos. 765/400/33 kV ICT at South Olpad. This source shall be stepped down to 433 V by means of station service transformer of minimum 2000 kVA capacity and rated 33/0.433 kV.
- b) Completely separated secondary distribution (415 V) systems for the auxiliaries of each converter.
- c) Duplicated supply by two different 415 V power sources to essential loads
- d) Diesel Generator (DG) Set of minimum 1500 kVA capacity per pole shall be provided to meet essential loads. This generator set shall start automatically and cater load immediately in case of loss of all the normal and standby supply sources. The DG sets shall be designed and rated so as to meet the load time characteristics of the essential loads of the entire station as determined by the TSP with a 10% margin on the load.
- e) Parallel operation between station service transformers shall not be permitted at any voltage level in order to limit fault currents, prevent back feed into the AC bus and to ensure independence of supply sources. Also, parallel operation shall not be permitted between transformers and the DG set.
- f) Suitable protection on all primary MV and LV supply connections shall be provided.
- g) The 220 V DC supply system(s) per pole shall consist of at least two independent DC systems; each system consisting of one float-cum-boost charger, one battery bank and one distribution panel. A 48 V DC system consisting of two battery sets, two battery chargers and two distribution boards shall also be supplied for communication panels (wherever supplied). If desired, 48 V supply may be obtained from 220 V DC battery bank by use of adapters, without compromising backup time.
 - (i) The station services DC system shall cater to the DC loads of HVAC and HVDC switchyards, auxiliary services control, valve and pole control, protection circuits, communication system loads etc.
 - (ii) Minimum lighting load shall be connected to the station DC system.

Transmission Service Agreement

- (iii) Sizing of 220 V battery and battery charger shall be done based on the number of bays specified (including future bays) as per CEA Regulations and relevant IS. 2 sets of 48 V battery banks for PLCC and communication equipment for present and future scope shall be provided at each new Substation with at least 10-hour battery backup and extended backup, if required.
- h) All auxiliaries shall give rated output at voltage variation of $\pm 10\%$ and frequency variation of -5% to $+3\%$. Sizing of LT Switchgear shall be suitable to cater the requirement for all present and future bays. AC and DC distribution boards shall have modules for all the feeders (including future as specified).
- i) For substation extensions, existing facilities shall be augmented as required.

An indicative SLD for the Auxiliary Supply System is enclosed at '**Appendix-C.5**'.

For the requirement of the Auxiliary Power as described above, Essential Load is defined as per below: -

Essential loads: *These are the loads whose failure shall affect the conversion capability of the HVDC system. These loads shall include, but not be limited to, the cooling and other auxiliaries of the converters, the cooling of transformers and reactors, valve hall cooling, etc. In addition, loads that must remain working in case of complete loss of the AC power supply shall also be included in essential loads. These loads shall include, but not be limited to, the station battery chargers, disconnecting switching and circuit breakers operating mechanism, the emergency lighting, fans to keep over pressure in valve halls, etc.*

35. Fire Detection, Alarm and Protection system:

A comprehensive fire detection, alarm and protection system as per Central Electricity Authority (Measures Relating to Safety and Electric Supply) Regulations, 2023 shall be provided. Valve Hall shall have Air aspiration system (fast and early smoke detection system). Suitable Infra-Red (IR) and Ultra Violet (UV) detector to detect the flashover inside the Valve Hall shall also be provided. The Valve hall wall towards converter transformers shall be suitable for minimum 3-hour fire rating.

Suitable fire detection system using smoke detectors and/or heat detectors shall be provided in HVDC Station for all room and areas. These smoke fire detection systems shall be connected to a separate Fire annunciation system clearly identifying the zone.

Hydrant System:

Suitable No. of hydrants shall be provided for protection of HVDC Station equipment in the yard and HVDC Station building.

HVWS System:

High Velocity Water Spray (HVWS) system shall be provided for converter transformer, ICTs and Shunt Reactors.

36. Testing and trial operation

All equipment/ components including IGBT valves, Converter Transformers, smoothing reactors, EHV DC Transformer bushings and wall bushings shall be subjected to Type tests, Routine tests, Factory Acceptance Test (FAT), Site Acceptance Test (SAT) as per relevant IS / IEC/ IEEE as applicable. The SAT shall consist of sub-system and system tests and shall be carried out after installation of equipment at site. The sub-system tests cover the major sub-system like valve cooling, AC and DC filters, HVDC converter, auxiliary systems, communication etc. After completion of sub-system tests, system tests covering power transmission tests, transient and dynamic control tests, measurement of electric field and RFI etc. shall be conducted. After completion of all system tests, final trial operation of the HVDC System shall be carried out for continuous period of normal operation of not less than 10 days for each Pole/Bipole separately. The HVDC System shall be declared under Commercial Operation after the successful completion of its Trial Operation.

37. Reactive power exchange

The 400 kV Bus sectionaliser at KPS3 is planned to be normally open. However, the design should also consider the possibility of 400 kV Bus sectionaliser to be kept open/closed based on system conditions.

Each monopole shall have a capability of providing dynamically varying reactive power between 0.95 leading power factor to 0.95 lagging power factor at PCC for any active power between -1250 MW to +1250 MW. This capability shall be achieved at all AC voltages within the continuous operating limits and ambient temperature limits. For voltages outside the continuous operating limits, the reactive power support shall be provided as per LVRT/HVRT strategy.

The control of reactive power exchange with AC grid in response to Q mode or V mode of RPC shall be fully automatic and shall be continuously monitored. The control equipment, however, shall allow both automatic and operator-initiated switching. In the former case, adequate annunciation shall be provided to the operator.

Fault infeed during faults shall be 1 p.u. of rated AC current for dead short circuit at Converter transformer AC bus. Dynamic reactive power support shall be over and above the steady state reactive power support.

The studies of DC Current flowing through breakers on AC side of converter transformer for earth faults on converter side of transformer at locations as applicable and sizing of auxiliary resistor to ensure zero crossings in the total current in the AC breaker.

Transmission Service Agreement

Each breaker used for switching shunt reactive elements shall have point-on-wave switching control for energizing its branch, to minimize voltage disturbances while switching capacitors and filters, and minimize DC offset current while switching shunt reactors. Breakers used for switching shunt reactive and filter elements must be capable of de-energizing their branch at the maximum temporary overvoltage conditions specified in this specification, or as determined by the TSP's studies, including full load rejection studies, whichever is greater. The reactive compensation and overvoltage limiting equipment shall be designed such that at any power transfer level up to rated power in either direction, a complete or partial interruption of DC power transfer shall not result in a fundamental frequency over voltage beyond the values specified in this specification.

All the necessary studies of reactive compensation and voltage control shall be performed. The calculations of reactive power exchange and of voltage control shall be based on the most unfavorable combination of tolerances on equipment, connected system configuration and of changes in operating conditions.

38. Pole Blocking

The HVDC System shall recover to 90% of the pre-fault DC power transfer level consistently within about 300 milliseconds from the instant of fault clearing, without sustained oscillation for all inverter system fault conditions. For all rectifier AC system fault conditions, the recovery time, to 90% pre-fault power level, shall be within 100 milliseconds from the instant of fault clearing. This recovery time shall be achieved for all short circuit levels as defined in this specification.

If it is in the interest of the overall improved recovery of the AC/ DC system, in such cases the recovery times other than those specified shall also be acceptable, subject to review

39. Pole Deblocking and Converter Start-up

A coordinated sequence of starting an HVDC Pole shall be established and demonstrated during FAT. The sequence shall be in a such a manner that it will not impact the connected AC system beyond steady state abnormal voltage limits. It shall be possible to start and deblock at minimum DC power specified in this specification earlier while maintaining all the AC and DC filter performance requirements.

40. AC bus fault

The TSP shall demonstrate the response of the power controller to DC voltage changes in the rectifiers and inverter for solid converter AC bus faults, both single phase-to-ground and

Transmission Service Agreement

three phase-to-ground.

The HVDC system shall recover to 90% of the pre-fault DC power transfer level consistently within 120 ms from the instant of fault clearing, without sustained oscillation for all inverter AC system fault conditions. For all rectifiers AC system fault conditions, the recovery time, to 90% pre-fault power level, shall be within 100 ms from the instant of fault clearing. This recovery time shall be achieved for the fault levels above the minimum specified in Table-1. Recovery times greater than specified above shall be acceptable only if the higher recovery times results in the overall AC and DC system improvement.

The response time shall be determined in accordance with the general criteria defined in this specification. The specified response for the rectifier AC system and inverter AC system faults shall be demonstrated [400 kV level at KPS3 (HVDC), 400 kV and 765 kV level at KPS3, 765 kV level at KPS2, 765 kV level at Lakadia, 400 kV level at South Olpad HVDC, 400 kV and 765 kV level at South Olpad, 765 kV level at Vadodara, 765 kV level at Ahmedabad, 765 kV level at Boisar-II] for the following conditions:

- (i) Single phase-to-ground faults, for five cycle, ten cycle, and twenty cycle fault clearing and with fault levels resulting in voltage reduction to 90%, 70%, 50%, 30%, 20%, and 5% of nominal converter AC bus voltage.
- (ii) Three Phase-to-ground faults, for five cycle fault clearing, with fault levels resulting in voltage reduction to 90%, 70%, 50%, 30%, 20% and 0% of nominal converter AC bus voltage.
- (iii) Zero impedance three phase 400 kV AC busbar faults at Khavda and South Olpad which are cleared after five cycles and which result in the loss of one DC pole.
- (iv) Three phases to ground, five cycle, and Single line to ground, ten cycle faults. The outage of components would include 400 kV single circuits, 400 kV double circuits if these are on same tower, generator, filter bank etc.
- (v) Three phase to ground, five cycle, and Single line to ground, ten cycle faults following conditions when system is already running under single contingency and which result in outage of further system components. The outage of components would include 400 kV single circuits, 400 kV double circuits if these are on same tower, generator, filter bank etc. Under such conditions it shall be shown that the system stability is maintained although the time required for recovery may exceed the values given above. For certain cases if there is a need for run back condition on HVDC the same shall be evolved by the TSP.
- (vi) TSP shall demonstrate LVRT and HVRT Capability as per the performance criteria mentioned in this document.

41. DC Line Faults

The DC line fault protection sequence shall detect the fault, de-energize the faulted line Pole by control action, allow a time period for fault deionization (settable between 50 ms to 1000 ms), and then automatically attempt restoration of the DC power transfer on the Pole.

For pole to ground faults, the TSP shall provide a sequence to de-ionize the fault and restart the monopole automatically after a predetermined programmable time. The first restart attempt shall be at pre-fault DC voltage and second restart attempt shall be at reduced DC voltage. The third attempt shall be in STATCOM mode. This constitutes one complete recovery sequence.

All equipment shall be dimensioned considering these 3 restart attempts.

The first restart attempt including fault clearing time and achieving pre-fault power level, shall not exceed 2 seconds for pole to ground faults, however, it shall be endeavor to minimise the fault recovery time. During second restart attempt tap changer may be used to achieve reduced DC voltage. The maximum time for the second restart attempt shall be limited to time taken by tap changer or the time taken by the drive of the breaker/switch to recharge. In case the second attempt fails then the converters shall automatically go into STATCOM mode of operation

The system shall be designed and capable of the following:

- a) During the DC line fault the power transfer on the non-faulted Pole shall be completed as quickly the extent possible in order to minimize the impact on the DC power transfer. This should be possible even when telecommunication is out of service.
- b) In case a fault occurs within 15 minutes of the last fault then both these faults shall be counted as attempts within single DC line fault recovery sequence. A fault that occurs after 15 minutes of the last fault shall be treated as start of new DC line fault recovery sequence. Maximum cooling period between two consecutive DC line fault recovery sequences shall be 60 minutes during which tripping may be allowed.

The clearing and recovery of a DC line Pole fault shall be demonstrated in bipolar and monopolar mode at 1.0 p.u. power transfer prior to the fault for the particular mode. Faults shall be applied at the line ends and at the line midpoint in both power directions. The demonstration shall include the influence of the function provided to transfer power from the faulted Pole to the other Pole.

Suitable modeling of the DC line, which takes into account the electro-magnetic coupling between the Poles, shall be considered in the above studies.

All high voltage equipment in the VSC station including charging resistors and neutral bus

arresters shall have adequate thermal capacity to support an unsuccessful automatic restarts. In case DC line is tripped due to line fault, affected pole shall be left in a state ready for manual restart in STATCOM mode.

42. Operation During Reduced AC Voltage Conditions

To assist in the recovery of the network, the Converter Stations shall be able to continue operation with reduced AC bus bar voltages.

In addition to the requirements of operation under over voltage conditions specified in this specification, the converter equipment shall be able to continue operating without blocking of converters with AC bus voltage reduced below 15% of nominal voltage during three phase faults, and to zero on one phase during single line to ground faults, for a period of 1 second followed by voltage recovery to 80%. In this condition, reactive power feed to fault shall be prioritized. The converters shall continue to transmit power to the extent possible under the above reduced voltage conditions. The valves as well as all the cooling equipment shall be rated for these conditions. The cooling system shall not trip during AC system faults.

43. Controlled Shutdown

Each Pole shall be able to be shut down in a controlled manner by the automatic reduction in the power order accompanied by appropriate AC harmonic filter bank switching. The block and isolation of a Pole shall be done without the block or shutdown of other Pole converters.

44. Power Runback

The controls shall be capable of achieving 90% of any step change requested by run-back modulation signals including within 200 milliseconds of receipt of the run-back signal.

45. Cyber security

The designed system shall be compliant with:

- a) IEC-27001 Information security management
- b) IEC-62443
- c) CEA (Cyber Security in Power Sector) Guidelines, 2021

Transmission Service Agreement

Cyber security shall be incorporated in the overall design of the HVDC controls, protection, communications, HMI and SCADA systems. The TSP shall propose a secure and robust design in the control and LAN systems, using next generation firewalls, dual firewall communication designs, routers, gateways, data diodes, etc. that have built in cyber secure measures.

46. Performance Guarantee for Converter Station (excluding HVDC line)

- a) HVDC Station losses: The Guaranteed losses of HVDC converter stations shall include the no load operating state loss and load losses during Operation with 100% rated active power(1250 MW / pole) and 100% rated reactive power (410 MVAR / pole). The Guaranteed losses shall be verified as per IEC 61803 and IEC 62751. The above losses shall be guaranteed at nominal DC voltage (± 500 kV at rectifier end) and nominal AC system Voltage (400 kV, 50 Hz) at ambient temperature of 40 deg C and relative humidity of 50%.
- b) No load loss shall be guaranteed corresponding to converter transformer set at principal tap^{##} with nominal AC system voltage and nominal frequency. Also refer maximum guaranteed loss figures in table below:
- c) The system shall meet various harmonic performance parameters on both AC side and DC side.

Design targets for HVDC station Reliability and Availability^{^^} and station guaranteed losses shall be as per Table-10.

Table - 10

1	Overall Energy availability of HVDC scheme (a) Overall Performance (b) Excluding transformer	Not less than 97% Not less than 98%
2	Forced Energy Unavailability (FEU)	Not more than 0.6%
3	Schedule Energy Unavailability (SEU)	Not more than 1%
4	Single Pole outage per station per year	Not more than 8 (with average outage duration of 7.5 hours)
5	Bipole outage per station per year	Not more than 0.2 (with average outage duration of 8 hours)
6	No-load operating state losses	0.2 % of Bipole Rating per station
7	Load losses at operation with 100% rated active power and 100% rated reactive power at nominal DC Voltage	Max-1.0-% of Bipole Rating per station

Transmission Service Agreement

##Principal tap is the Tap Position of converter transformers when HVDC converters shall be delivering 1 p.u. power (2500 MW, 0 MVAR) at nominal DC voltage at rectifier (± 500 kV) keeping AC system voltage 400 kV, 50 Hz at 40 deg C ambient temperature and humidity of 50%.

^^The details for calculating Availability are mentioned in '**Appendix C.4**'.

For the loss guarantee stated above, following equipment/systems shall be considered:

a) Determination of losses

The total losses of the HVDC converter station other than HVDC valves shall be calculated as the sum of the losses determined for each individual equipment in line with IEC 61803. The major components to be included in the loss calculation and guarantees and the method of assessment for each component shall be as follows, as applicable:

1. Converter Transformers as per IEC 60076-57-129
2. Phase/ valve reactors
3. DC Smoothing Reactors
4. Converter Valves as per IEC 62751
5. High frequency damping circuits (if applicable)
6. Reactive Power Equipment, AC Filter
7. Auxiliary Power Transformers
8. DC Filters and 50 Hz blocking filter as per IEC 61803
9. Losses for RI and PLC filters
10. All items covered in IEC 61803

Specific Exclusion:

Equipment specifically excluded from the loss calculations shall be the oil treatment plant and firefighting load, station auxiliary system energy consumption (such as illumination of indoor and outdoor services, Air conditioning and ventilation system for control room, service building, kiosk, battery and battery charger etc.) except auxiliary power consumption required by Converter transformer cooling and Valve cooling system.

b) Guaranteed Failure Rate of Power module.

The maximum annual guaranteed Power module failure rate shall not exceed 1.0 % per pole per station. The failure rate shall not include failures directly attributable to operating and maintenance errors.

c) AC/DC HV Filter Capacitor Failure Rate Guarantee (If applicable)

Transmission Service Agreement

The maximum guaranteed annual capacitor failure rate shall not exceed 0.15% except first unit failure. The capacitor shall be considered as failed if its Capacitance value varies more than $\pm 5\%$ of the (actual measured) name plate value or as indicated by manufacturer. Leakage of oil from the capacitor and deformation of the capacitor unit shall be considered as a failure even if the capacitance value is within the tolerance limits. Failure rate shall be monitored on per pole per station basis.

d) Flashover Guarantee

Flashover is defined as breakdown of insulation for self-restoring insulation media which leads to outage as defined elsewhere in this specification. TSP shall guarantee that there shall be not more than two pollution related flashovers per station per year for DC yards (base environmental conditions as given in this specification will be considered). In case of a flashover, TSP shall make necessary investigations to establish the cause of the same, propose mitigation measures and implement the same.

e) Guaranteed Failure Rate of Relay Module/ C&P Module/Component

The guaranteed failure rate of relay module/ C&P module/ component shall not be more than 0.5% (except 1st unit failure). This will include individual circuit boards but not computers. The failures directly attributable to operation and maintenance errors and other incidents unrelated to the DC system shall not be included in the calculation. The relay module/ C&P module/ component failure rate shall be monitored on per pole per station basis.

47. Commissioning and start of operation

The purpose of commissioning period is to demonstrate to the Nodal Agency/Independent Engineer's satisfaction that the equipment is ready for its purpose and it functions satisfactorily under normal operating conditions. The testing and commissioning period will have the necessary duration to demonstrate the proper functioning of all the Project equipment and systems.

a) Site Testing

After the installation and preliminary adjustments of equipment, the Site tests shall be performed in the following stages:

Transmission Service Agreement

- Erection checks
- Commissioning tests
- Sub-system tests
- Sub-system energization tests
- System tests

The site testing has been categorized in above stages for the sake of convenience only. There may be overlapping of two or more stages for particular tests. The TSP shall perform the site testing with complete responsibility.

The TSP shall provide all instruments, equipment and facilities required to perform these site tests. Calibration certificates for the test equipment shall be made available at site prior to the start of the testing.

All special and test equipment necessary to simulate devices or switching sequences and required for commissioning shall be provided by the TSP. Results of the site tests shall be well documented and shall form a part of plant documentation.

48. Mandatory Spares:

The mandatory spares for the HVDC Station shall be as per 'Annexure-B, 4. Mandatory spares for HVDC stations (substation/switchyard level)' of CEA's 'Guidelines for availability of spares and inventories for power transmission system, transmission lines and substation/switchyard) assets, 2020'.

The specific exclusion to the above list is Sl. No. 2.1, Converter Transformer. Other Converter Transformer spares from Sl. No. 2.2. to Sl. No. 2.41 to be provided.

Minimum one No. (single phase two winding) spare Converter transformers of each type and rating per station, shall be provided. The spare Converter Transformers shall be inclusive of all fitments, hardware, bushings, as well coolers if mounted on the tank, accessories and oil complete in all respect.

49. HVDC building:

The Building shall comprise of but not limited to the following facilities:

1. Control and Relay Panel room

Transmission Service Agreement

2. ACDB and DCDB room
 3. Battery room
 4. Service Room cum workshop
 5. Valve hall
 6. Cooling system room
 7. AHU Room
 8. Valve Hall Ventilation Room
 9. Any Other room/facilities as per functional requirement
- 50.** For Type Test requirement of equipment, CEA's 'Guidelines for the Type Tests for major equipment of Power Sector' is to be followed.
- 51.** TSP shall supply complete VSC HVDC control and protection replica system without redundancy along with a real time simulator for both the poles based on project specification mentioned in this document. The software and hardware design philosophy of control and protection replica shall be based on the design of ± 500 kV, 2500 MW Khavda - South Olpad VSC HVDC system for the purpose of dynamic performance testing, commissioning, troubleshooting and optimization during operation and training. Figure-4 shows a general diagram of the scope of Control Replica.

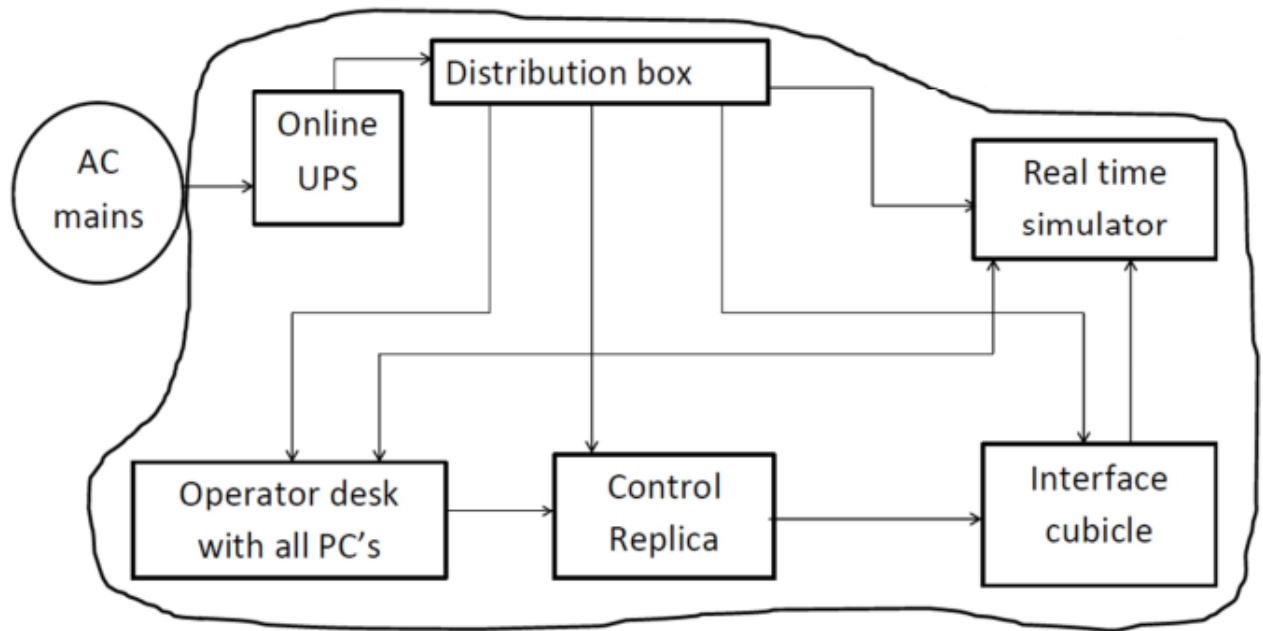

Fig 4 : Scope of contractor for Control Replica

Transmission Service Agreement

As show in Figure-4, the supply shall include simulator interface panel, station HMI, Transient Fault Recorder, Station GPS clock, network equipment, Uninterrupted Power Supply (UPS) system, communication cables, cable trays/racks, tools and tackles, suitable furniture including operator desk, spares and other accessories required to implement the Control Replica. The dynamic performance test for 2500 MW Khavda – South Olpad HVDC VSC Bipole may be carried out with Control Replica, and the same shall be delivered to site after completion of site acceptance tests. The simulator shall contain AC network modelled as both voltage sources behind short circuit impedance and detailed AC equivalent network as provided to enable TSP to carry out test cases with both options.

52. Applicable Standards:

All equipment and material shall be designed, manufactured, tested and commissioned in accordance with latest Indian Standards / IEC or IEEE standards, / CIGRE guidelines and the Acts, Rules, Laws and Regulations of India. Some of them are as follows:

Table 11

Sr.No.	Description	Standard
1	Terminology for HVDC transmission	IEC 62747
2	High-voltage direct current (HVDC) power transmission using voltage sourced converters (VSC)	IEC TR 62543
3	Performance of voltage sourced converter (VSC) based high-voltage direct current (HVDC) transmission – Part 1: Steady-state conditions	IEC TR 63363-1
4	High-Voltage Direct Current (HVDC) installations - System tests	IEC 61975
5	High-Voltage Direct Current (HVDC) systems - Guidance to the specification and design evaluation of reactive power exchanges	IEC 62001 (1-5)
6	Bushings for DC Applications	IEC 65700
7	Insulation Coordination	IEC 60071 (1-4,11,12)
8	Application guide for metal oxide arresters without gaps for HVDC converter stations	CIGRE report 33/14-05
9	Converter transformers	IEC 60076-57-129
10	Power transformers - Part 6: Reactors	IEC 600076-6
11	Shunt capacitors for AC power systems having a rated voltage above 1000 V	IEC 60871-(1-4)

Transmission Service Agreement

12	Guidelines for the system design of HVDC project	IEC/TR 63127 Ed. 1.0
13	SYSTEMS WITH MULTIPLE DC INFEED	CIGRE 364
14	Guidelines on Asset Management for HVDC Installations	IEC/TR 62978 Ed. 1.0
15	Transformer for HVDC applications	IEC:60076-57- 129
16	Surge Arresters – Metal Oxide Surge Arresters without gaps for HVDC converter stations	IEC: 60099-9- Part -9
17	Instrument Transformers	IEC 61869
18	Disconnectors and Earthing Switches	IEC 62271
19	Cyber Security	IEC 62443 IEC 27001
20	UPS, SMPS and Other Power supply units	IEC 62040 IEC 61558
21	Terminology for Voltage Source Converters for high-voltage direct current (HVDC) transmission.	IEC 62747
22	Power losses in voltage sourced converter (VSC) valves for high-voltage direct current (HVDC) systems - Part 2: Modular multilevel converters	IEC 62751
23	Voltage sourced converter (VSC) valves for high-voltage direct current (HVDC) power transmission - electrical testing	IEC 62501
24	Power losses in voltage sourced converter (VSC) valves for high-voltage direct current (HVDC) systems -: Modular multilevel converters- Part 1	IEC 62747
25	Testing and commissioning of VSC HVDC systems	CIGRE 697
26	Dynamic characteristics of inverter-based resources in bulk power systems	IEC 63401
27	IEEE Standard for Interconnection and Interoperability of Inverter-Based Resources (IBRs) Interconnecting with Associated Transmission Electric Power Systems	IEEE P2800- 2022
28	Wind Energy Generation Systems	IEC-61400
29	TESTING AND MEASUREMENT TECHNIQUES - POWER QUALITY MEASUREMENT METHODS	IEC 61000-4-30
30	Other items as per relevant and prevailing standards specified elsewhere in the specification for substation works.	

- i) CERC (Indian Electricity Grid Code) Regulations, 2023
- ii) Manual on Transmission Planning Criteria, 2023

Transmission Service Agreement

- iii) CEA Technical Standards for Construction of Electrical Plants and Electric Lines Regulations, 2022
- iv) CEA Technical Standards for Connectivity to Grid, Regulations, 2007 (including subsequent amendments)

DC Voltage Measuring Equipment

A proven type of voltage divider shall be provided for DC voltage measurement. The accuracy of the device shall not vary more than 0.5% with an ambient temperature change of 50° C. The overall voltage measuring system shall have an accuracy of at least 1.0% of full scale. The response time shall not be longer than 150 micro seconds, accepting an overshoot of up to 20% at that rise time. The measuring system shall achieve proper operation of the control and protection system to which it is connected.

The measurement range shall be sufficient to measure voltages up to 1.5 p.u. Preference shall be given to devices which provide isolation between the HV primary connection and the output signal. If the output signal is not completely isolated from the HV connection, protection shall be provided to limit the possible output signal voltages to less than 2 kV in the event of a fault on the device.

All low-level signals shall be cabled separately from high level signals. The divider shall be so arranged that no leakage current on the surface of the insulator can pass to the measuring circuit. The insulator shall for this reason be continuous without any metallic intermediate flanges. Furthermore, the interior of the divider shall be so arranged that interior leakage currents do not influence the measurement.

For voltage measuring equipment to be erected in the outdoor switchyard, it shall be ensured that discharge activity on the housing shall not cause interference with the output signal.

For each voltage measuring device furnished, all necessary auxiliary power plus any equipment necessary for the transformation of the auxiliary power to an acceptable form shall be provided. Such transformation equipment shall be mounted in the control cubicles.

For power quality measurement compatibility, the transducers including its interface with control and protection panels and display like Transient fault recorders should be compatible with IEC 61000-4-30 Class A in order to check compatibility with Grid Connectivity requirements over and above the requirements given above.

Direct Current Measuring Equipment

Direct Current Transducers supplied shall be mounted in bushings, if available. In locations where bushings are not available, free-standing transducers shall be provided. For each transducer furnished, the all-necessary auxiliary power plus any equipment necessary for the transformation of the auxiliary power to an acceptable form shall be provided.

The design of the measuring system shall be based on maximum interchangeability where any electronic module shall be compatible with any of the core and coil assemblies.

The transducer output signal shall be of sufficient magnitude to ensure that the content of the signal is usable at all levels of primary current from 1% to 300% of the rated current, with a measurement output possible up to 600% before saturation of the output signal occurs.

In the event of high current (up to 0.2s short circuit current), the DC CT shall remain unsaturated for 20 ms or longer. This time shall be measured from the instant the current attains 10 pu. The DC CT shall be provided with interlock circuits that indicate saturation of the DC CT, as well as DC CT faults.

It shall be ensured that any low-level signals generated are kept shielded from interference due to other higher voltage circuits. The low-level signals shall be cabled separately from high level signals.

It shall be ensured that all DC current measurement outputs are accurately calibrated with all the respective loads connected. Sufficient buffered outputs shall be provided at the time of the initial installation for all future output signal requirements. If required, on-site adjustments to output calibration shall be possible. The sensitivity of the devices supplied for such calibration shall be appropriate for setting the required accuracy.

The electronic module shall be provided with interlock circuits to indicate that the measuring system is fully operable.

Each transducer shall be provided with a capacitive tap.

In case of Optical DC measuring system, the materials used in it shall be non-corrosive in nature.

For power quality measurement compatibility, the transducers including its interface with control and protection panels and display like Transient fault recorders should be compatible with IEC 61000-4-30 Class A in order to check compatibility with Grid Connectivity requirements over and above the requirements given in this specification.

Transmission Service Agreement

Stationary Accuracy

The composite accuracy of all DC current measurement systems used for protective purposes shall be equal to or better than $\pm 2\%$ of rated DC current up to 120% of the maximum rated current and $\pm 10\%$ of rated DC current up to 1.2 times peak calculated fault DC current.

All DC current measuring system used for control purposes shall have a composite accuracy of $\pm 0.75\%$ of rated DC current from minimum rated current to 120% of the maximum rated current and $\pm 10\%$ of rated DC current from 120% up to 300% of the rated current.

All transducers used for corresponding functions, e.g. pole differential protection etc shall have matching accuracies equal to or better than $\pm 2\%$ of rated current up to 300% of the rated current.

Dynamic Accuracy

The response of the measuring systems shall be such that a linear current change within 150% of maximum rated current and with a rise time of 45 ms, is tracked by the transducer output with an error which does not exceed +0%, -2% of rated current on any point of the curve. The rise time is defined as the time required for the current to change from 10 to 90% of the full current change. The frequency response shall be within +3% at 1500 Hz.

Operator's Control, Monitoring and Support Systems

A. General Requirements

All hardware such as computers, computer peripherals/printers/ accessories, testing equipment etc and networking products shall conform to latest products based on industry standard. It shall be possible to fully monitor and control both stations as described below-

- Operation control of both converter station (from monitors) from Khavda
- Operation control of both converter stations (from monitors) from South Olpad
- In separate operation control mode, all the terminals shall be able to control their own station individually.

The above selection modes shall be separately provided for control of the DC system and the AC systems of either station.

A Station operator desk to be supplied at each converter station shall be able to control the stations. The control shall be possible from TFT Monitors and operator key board/ mouse. In the event of failure of the system, control and monitoring shall be by means of direct control at the Bipole control panels, circuit breaker controls panels etc. generally as shown in 'Figure-A'. This control could be made from PC connected to these control panels and necessary interface shall be provided to achieve this. The control functions to be provided from the equipment control panels shall include at least those listed under 'Table-A' and 'Table -B'. It shall also be possible for operator to know individual alarms by selecting the particular panel on the display monitor.

The TSP shall provide the equipment necessary for the purpose of control, status indication and metering of all equipment (keeping in view the intermediate Bay Kiosks to be provided in AC and DC yard,) Khavda and South Olpad.

The control room shall generally house the following equipment:

- Operator control, monitoring and support system
- DC line fault location equipment, if not integrated within C&P system.
- Transient fault recorders, if not integrated within C&P system.
- Master controller equipment, if not integrated within C&P system.
- Station fire alarm, control and monitoring panel

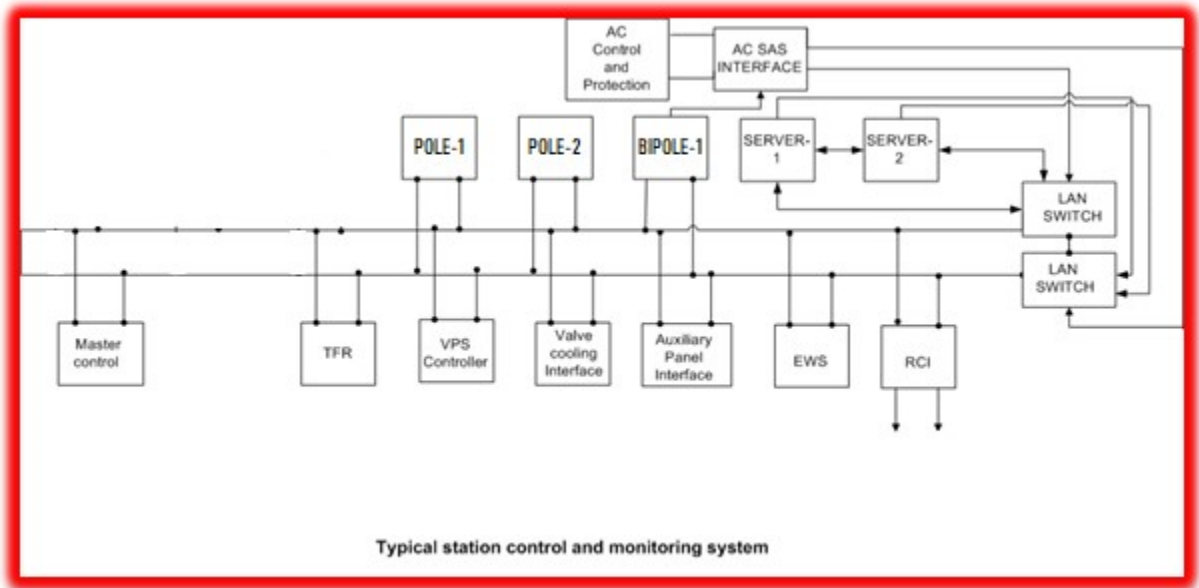

'Figure – A'

(System shall be redundant with system A and system B. Only one system has been represented.)

i. HVDC Controls

The station control room at each converter station shall have facilities that include, but not be limited to, the functions shown on Table-A and B

A description of major HVDC control functions is outlined below:

1. Controlling Station (Master Station) Selector Switch

Control location selector switches shall be provided in each station control room. These selector switches shall enable the operator to control the HVDC system and/or the HVAC yard of any converter station from either Khavda and South Olpad stations. HVDC and HVAC yard control and monitoring of other converter station shall be provided from TFT Monitors.

2. Bipole Controls

Bipole controls shall refer to the common control functions that affect both poles in a Bipole. These functions are typically Bipole power order, power direction, power limit and power ramp rate.

The power flow over the Bipole shall be maintained at the Bipole power order as set by the operator.

Transmission Service Agreement

The power ramp rate shall control the timing sequence for loading Bipole at a pre-selected rate (within specified range) set by the operator.

The power limit control shall enable the operator to set different limits to Bipole loading. It shall also be possible to operate each pole separately from Bipole Controls.

3. Pole/Converter Current Order/Limit

The power setting divided by voltage shall determine the current order to either pole. However, this shall not preclude the ability to control each pole, by means of a directly entered manual current order signal.

The pole current limit set point shall enable the operator to raise/ lower current limits to optimize link capabilities under varying conditions such as ambient temperature, temporary reduction in capability etc.

4. HVDC System Control Mode Selection (Per Pole)

The following basic control modes shall be provided:

- a) Active Power Control Mode
- b) DC Voltage Control Mode

Disturbance free transfer of any pole from one control mode to another shall be possible.

5. Miscellaneous Operator Controls

- a) DMR (Dedicated Metallic Return) Line Current Null Control

This control shall enable the operator to null the current flowing in the DMR (Dedicated Metallic Return) Line resulting from unequal sharing of load between poles during balanced operation.

- b) Block/ Deblock

This control shall enable the operator to stop (block) or start (deblock) a converter. Automatic sequences shall be provided to fulfil preconditions for deblock. A normal stopping sequence initiated by "block" contact involves a sequence at each end that causes the voltage and current to drop to zero.

- c) Pole Start/ Stop

This control shall enable start or stop of the complete pole, comprising converters at either of the rectifiers and the inverter and shall take care of all interlocks, start/stop preconditions and sequences automatically.

Transmission Service Agreement

d) Direction of Power Transfer

Power flow shall be possible in both directions.

e) Pole Metallic Return/DMR (Dedicated Metallic Return)

This selector switch (or switches) shall enable an automatic sequence from Pole metallic return to DMR and vice versa. This mode change shall be possible even with power flowing in the DC system.

f) DC Filter Connect/ Isolate

Motorized disconnects are specified for switching the filter arms to allow disconnection of a faulty filter bank or arm and for restoration to service as quickly as possible. An automatic switching sequence shall be provided which shall take care of all the interlocks.

g) DC Line Isolator

DC line isolators are specified for maintenance purposes and their electrical operation in local shall be possible. Operation shall be permitted only with pole blocked and station ground connected. Automatic operation shall also be possible if required by any sequences subject to satisfying all interlocks permitting the operation.

h) Grounding Switches in DC Yard

Grounding switches are specified for the DC switchyard area to allow each isolatable section of bus to be grounded. Only local electrical operation is required. However, if operation of any grounding switches is part of any automatic sequence(s), or is specified elsewhere, then those grounding switch(es) shall be operable locally as well as remotely.

i) Valve Hall Ground Switches

Remotely controlled motor operated grounding switches are specified for the valve halls to protect maintenance personnel. The operation of all the valve hall ground switches together as a group shall be possible by initiating a sequence from the control room. Provision shall however be made (key operated switch) for defeating the interlock to permit entry of personnel into the restricted area of the valve hall.

j) Maintenance/Bypass Isolators for Metallic Return Transfer Switch / Bus (MRTS or MRTB)

Electrically local operated isolators shall be provided to establish a ground reference when MRTS is being maintained. These shall be interlocked with the MRTS.

k) Emergency Stop

An emergency stop button on pole basis shall be provided in the control room. Operation of this button shall automatically ramp down at a fast rate the direct power, lead to

Transmission Service Agreement

blocking of the converters and reach safe shut down with Operation of High speed parallel/ De-parallel switches.

i) HVAC Controls

HVAC controls shall consist of close-open operations for circuit breakers and motor operated disconnectors.

ii. Station Control Facilities

The TSP shall provide the control facilities from the operator control desk through a TFT monitor and keyboard/ mouse system. These facilities shall include all control operations, digital setting, indicating devices, Station single line diagram and symbols, any other special control devices and meters required for control and monitoring of the complete HVDC system. The layout of the station single line diagram, together with control, indicating and metering devices on the control desk shall be logical, compact, and shall facilitate efficient supervision and operation of the station(s) by the operator.

iii. Station Level Status Supervision

The position of each switchgear e.g. Circuit breaker, isolator, earthing switch, transformer tap changer etc. shall be supervised continuously. Every detected change of position shall immediately be displayed in the single-line diagram on the station screen, recorded in the event list and an option to take hard copy printout of event list shall be available. Alarms shall be initiated in the case of spontaneous position changes.

The switchgear positions shall be indicated by two auxiliary switches, normally closed (NC) and normally open (NO), which shall give ambivalent signals. An alarm shall be initiated if these position indications are inconsistent or if the time required for operating mechanism to change position exceeds a predefined limit.

iv. System Indications and Power Measuring Facilities

The TSP shall provide DC and AC system / equipment indication facilities in the station control room at each converter station that shall include, but not be limited to, the functions shown on Table A and Table B. Alarms of slave stations shall be indicated and displayed both at Master Station and slave stations and vice-versa.

Graphic representation of valves and valve cooling piping network shall be provided on station monitoring system. The graphical representation shall also display faulty power modules in different colours indicating faulty power module position.

Pressure, temperature and relative humidity of each valve hall shall also be displayed in the control room. Alarm(s) shall be raised in case any of the parameters exceed limits.

Transmission Service Agreement

'Table A' provides a list of minimum AC and DC metering facilities required, which shall be included on TFT monitors.

v. Energy Metering

Energy meters as per relevant CEA Guidelines and Specifications/Regulations for the 765 kV , 400 kV , 220 kV and 132 kV AC switchyards (as applicable) and 33 kV feeders at HVDC terminals shall be provided by the TSP.

B. System Requirements

General

The main control and monitoring systems shall be configured as dual redundant computer-based systems in a main and hot standby configuration generally as shown in 'Figure A'. The operator control, monitoring and support system could be integrated with station control system. Outage of any subsystem or complete loss of one system shall not affect the control and monitoring of the HVDC station. The system shall be based on open system concept in hardware and software and industry standard communication protocols and graphical user interface.

The redundant, computer-based system shall accept control inputs from the Operator by means of TFT monitor/ mouse etc and send these commands to the HVDC and the HVAC control systems.

The system shall gather alarm, status and measurand data from the plant and display it to the Operator on the mimic diagram on TFT monitors, loggers etc. as further defined below. The system shall be so designed that no alarm and status data or control data shall be lost.

Table -A Controls and Indications at Khavda and South Olpad :-

Sl. No.	Signal Name	Khavda	South Olpad
	CONTROLS SIGNALS		
1.	Bipole power order	√	√
2.	Bipole power order ramp	√	√
3.	Bipole power order limit	√	√
4.	Bipole power/current control	√	√
5.	Power direction P1, P2	√	√
6.	Power/Current control P1, P2	√	√
7.	Current order setting	√	√

Transmission Service Agreement

Sl. No.	Signal Name	Khavda	South Olpad
8.	Current ramp start/stop	√	√
9.	Current order ramp setting	√	√
10.	Current limit setting	√	√
11.	Master station transfer	√	√
12.	Metallic/DMR switching	√	√
13.	Reduced voltage on/off P1, P2	√	√
14.	Start/Stop and Block/deblock P1, P2	√	√
15.	Power Swing modulation on/off	√	√
16.	DC power /current control	√	√
17.	Emergency stop P1, P2	√	√
18.	Frequency control/on/off	√	√
19.	Frequency target/limits	√	√
20.	Connect/isolate P1, P2	√	√
21.	Joint/separate, Sync/Async	√	√
22.	DC Filter connect/isolate P1, P2	√	√
23.	RPC auto/man off switching	√	√
24.	RPC Volt/Reactive Selection	√	√
25.	RPC MVar/Voltage set points	√	√
26.	Open line test auto/man P1, P2	√	√
27.	AC Filter (bank/ sub-bank) breaker open/close	√	√
28.	Conv. Trans Breaker open/close	√	√
29.	AC Filter (bank/sub-bank) Disconn open/close	√	√
30.	Conv. Trans Disconn open/close	√	√
31.	Tap changer auto/man P1, P2	√	√
32.	Valve hall Gr. Switch open/close P1, P2	√	√
33.	Khavda Sw. yard Breaker open	√	√
34.	South Olpad Sw. yard Breaker open	√	√
35.	Sub Synchronous Resonance Detected	√	√
36.	Sub Synchronous Damping Control Activated,	√	√
37.	Power Oscillation Damping Activated	√	√
38.	Sub Synchronous Control Interaction Detected	√	√
39.	Sub Synchronous Control Damping activated	√	√
	INDICATIONS		
40.	DC OP Mode Pwr./current	√	√

Transmission Service Agreement

Sl. No.	Signal Name	Khavda	South Olpad
41.	Gr/metallic return indication. P1, P2	√	√
42.	Power direction P1, P2	√	√
43.	Pole Telecommunication healthy	√	√
44.	Pole blocked/deblock P1, P2	√	√
45.	Master station Khavda-South Olpad- LDC	√	√
46.	STATCOM Mode on	√	√
47.	Power ramp in progress	√	√
48.	Stabilization control on/off	√	√
49.	Full/reduced DC voltage indication P1, P2	√	√
50.	Tap changer Auto/Man indication.	√	√
51.	Pole connect/isolate indication.	√	√
52.	Power direction normal/reverse	√	√
53.	Runback activated indication.	√	√
54.	Frequency control on/off	√	√
55.	Frequency control activated	√	√
56.	AC bay Circuit breakers indication Phase wise.	√	√
57.	AC bay disconnectors indication.	√	√
58.	Bypass Breaker Indication Phase wise	√	√
59.	Pole Discharge Switch Indication	√	√
60.	DC filter con/isolated indication.	√	√
56.	Grid Forming Mode Enabled	√	√
57.	Grid Following Mode Enabled	√	√
58.	Virtual Synchronous Machine Mode Active	√	√
59.	DC Voltage Control Station	√	√
60.	Active Power Control Station	√	√
61.	HVRT / LVRT Activated	√	√

Table -B Indication Signals to RLDC

S. No	Signal Name	RLDC
1.	Bipole power order	√
2.	Power Swing modulation on/off	√
3.	DMR/metallic return indication. P1, P2	√
4.	Pole blocked/deblock P1, P2	√

Transmission Service Agreement

5.	Runback activated indication.	√
6.	Frequency control on/off	√
7.	Frequency control activated	√
8.	Full/reduced DC voltage indication.	√
9.	AC bay Circuit breakers indication.	√
10.	AC bay disconnectors indication.	√
11.	DC Power Bipole	√
12.	DC Line current/ voltage P1. P2	√
13.	AC side A/MW/MVAR/ P1, P2	√
14.	AC Filter/Cap A. MVAR all banks	√
15.	AC Lines A/MW/MVAR/	√
16.	Station/AC system MW exchange	√
17.	Station/AC System MVAR exch.	√
18.	AC Bus Voltage	√
19.	AC Bus Frequency	√

The system shall also be designed to allow input of signals from the Dispatch centre - for example, load frequency control (LFC) signals. The system shall be capable of meeting the control and monitoring requirements of each converter station and LDC while operating at maximum rating, with a reserve capacity of minimum twenty-five per cent. Equipment bins that are not fully equipped with cards shall be fully wired and be ready to accept additional cards. Power supply units shall be rated to meet the full capacity requirements.

C. Functional Requirements

1. General

The redundant computer-based system shall be a highly reliable integrated system, which shall provide Operator's interface, alarm and monitoring system and operator guidance/ expert system.

The high-voltage apparatus within the station shall be operated from different places:

- Remote control centres
- Station operator control.
- Local Bay controller IED (in the bays)

Operation shall be possible by only one operator at a time. The operation shall depend on the conditions of other functions, such as interlocking, synchro-check etc.

2. Run Time Command Cancellation and Self-Supervision

Transmission Service Agreement

Command execution timer (configurable) must be available for each control level connection. If the control action is not completed within a specified time, the command should get cancelled. Continuous self-supervision function with self-diagnostic feature shall be included.

3. User Configuration

The monitoring, controlling and configuration of all input and output logical signals and binary inputs and relay outputs for all built-in functions and signals shall be possible both locally and remotely.

It shall also be possible to interconnect and derive input and output signals, logic functions, using built-in functions, complex voltage and currents, additional logics (AND-gates, OR gates and timers). (Multi-activation of these additional functions should be possible).

The Functional requirement shall be divided into following levels:

- a) Bay Level Functions.
- b) System Level Functions.

D. Computer Information System Requirement:

A computer-based information system shall perform following functions:

- Initiation of commands to control HVDC system.
- Control and monitor the Valve cooling system.
- Monitoring of process data to give brief overview as well as a comprehensive view of each subsystem.
- Sequence of event recording and alarm system including determination of Event Categories (major, warning, alarm).
- Process data archiving and trending.

Soft copy of complete station documentation shall be available on Operator Work Stations.

All the system trends shall be available at least for one-year period and retrievable on demand from the main storage system. The process data logging shall have hourly/ daily logging of station data. Archiving and back up storing facility of the log sheets shall be possible and facilities taking backup on External hard discs/ Drives minimum 2 tera bytes shall be provided.

E. Remote Control, Monitoring and Tele Control systems

Transmission Service Agreement

The TSP shall provide facilities for coordinated control and monitoring of the HVDC system. All required remote control and remote monitoring facilities shall be provided at each converter station. Complete remote monitoring of each converter station shall be possible from opposite converter station. The HVDC tele-control system equipment shall be used in the processing of signals to be transmitted over the fibre optic communication system between the converter stations of Bipolar scheme.

Transient Fault Recorders

1. General

The transient fault recorders (TFR) shall continuously monitor the power system. These could be integrated with operator control and monitoring system or supplied as standalone units.

Below requirements are specified for standalone units. Similar functional requirements will be applicable for integrated TFR.

One recorder per pole shall be provided at each converter station. The TFR may be provided in the form of central unit together with Data Acquisition Units (DAUs). Initiation by any one of the fault detecting sensors or external initiating contacts shall cause the fault recorder to record on all channels. The record shall comprise-fault information, time of fault information and post fault information. The TSP shall determine the number of analog and event inputs required for each recorder and supply these number plus minimum 25% spare channels. The TFR shall also have facility for harmonic analysis upto 100th harmonics, inter-harmonics of waveforms. Transient fault recorders should be compatible with IEC 61000-4-30 Class A in order to check compatibility with Grid Connectivity requirements over and above the requirements given below. It should also be compatible for checking DC harmonic performance values.

Recorders shall be of solid-state modular construction microprocessor based and without moving parts. First in, first out (FIFO) printing logic shall be used. The necessary software for directly analyzing the records on the memory of the TFR shall also be supplied.

Facilities shall also be provided for data retrieval from TFR and analyse by means of a master station based on compatible PC having minimum configuration of 2.8 GHz clock speed, 1 TB hard disc and 16 GB RAM capacity, complete with 24-inch LED monitor, keyboard/ mouse etc and include laser colour printer with capability to print on A3 and A4 size paper. All necessary software package(s) along with facility to communicate between TFR and PC shall be provided by the TSP.

2. Input Signals

The input signals and starting sensors required for the HVDC system for commissioning and operation shall be determined by the TSP. The input signals to each fault recorder system for a pole shall include, but not be limited to, the following:

- Converter module voltage;

Transmission Service Agreement

- Converter arm current
- Converter module energy

- Reactive Power Control Values Active Power Control Values Control references and limits e.g. I_d , I_q , V_{dc} , P_{dc} .
- Pole Voltage Order
- Active and Reactive power order
- AC Voltage (Converter)
- Real and Reactive Power Measurement Values
- Real and reactive current Measurement Values
- Pole current order;
- DC line voltage (own pole);
- DC line voltage (other pole);
- DC neutral Bus voltage (Both poles)
- DC line current (own pole);
- DC line current (other pole);
- DC power (each pole and both converters)
- DC power (other pole and both converters)
- DC line to Line Voltage
- Line-Line DC voltage Reference value for the DC voltage control
- DC line current limitations
- Current order
- AC bus voltage (3 phases);
- AC current to each valve group and transformer primary currents.
- Positive Sequence Filtered Current as RMS value (network side)
- Positive Sequence Filtered Current as RMS value (converter side)
- Converter transformer Primary and Secondary voltages.
- Positive Sequence Filtered Line-Line Voltage Line side
- Positive Sequence Filtered line to line Voltage converter side
- AC Positive Sequence filtered Frequency
- DC Current in DMR line
- DC Neutral Current (Own Pole)
- DC Neutral Current (Other Pole)
- Ground Current on DC Side grounding point

The Triggering of TFR shall include all protection initiations and following inputs:

- Pole Block/ Deblock
- Pole gate triggering loss

Transmission Service Agreement

- Pole last Breaker opened
- Pole DC Protection Voltage level trigger
- Converter Protection operated along with different types
- Pole MR/ GR sequence initiated
- AC Over voltage/ under voltage Protection operated.
- Full voltage/ RVO Changeover
- DC O/V, U/V
- Telecommunication Fail.
- Converter Status including Converter/ Pole Block/ Deblock/ESOF/Transmission status/Rectifier/Inverter etc
- Pole PMR/ DMR sequence initiated
- Binary Converter Status Signals

Each fault recorder shall be equipped with suitable input circuits and starting sensors for all of the input signals. The TSP shall ensure that the characteristics of the input circuits and starting sensors are well matched to the characteristics of the signal sources.

3. Electrical Characteristics

(i) Monitoring Systems

The recorder shall be a digital based type. Operation of the equipment shall be based on programs stored in non-volatile solid-state memory. Programs shall be stable and no inadvertent change of program(s) shall occur.

The recorder shall be equipped with a built-in post fault record- length timer, adjustable over a range of 0.5 to 10 seconds after the fault.

Normally open operation alarm contacts shall close while the fault recorder system is operating and be utilized as inputs to the alarm monitoring and reporting system. A three digit, manually resettable operations counter shall be provided that indicates the number of faults or disturbances recorded.

Facility for automatic storage of information to a PC or an independent storage device (e.g. a disc drive) shall be provided. The output shall be possible to be printed on plain paper in the A4/A3 format.

The recorded information shall include but not necessarily be limited to:

- Station Identification
- Identity of trigger source
- Record Identification for Analog, Event and Sensor traces
- Date/ Time: Year, Day, Hour, Minute, Second, Millisecond
- Analog traces

Transmission Service Agreement

- Event traces
- Sensor traces
- Time marker trace which shall allow time interpolation of records to 2 ms.
- Start of record line.

(ii) Operations

The fault recorder shall continuously monitor the power system. Initiation by fault detecting sensors or by other input contacts or pre-selected events shall cause that particular recorder to record the fault information. The other pole recorder shall also record in a slave mode. Operation of any one of the initiating sensors shall start the recording mechanism or otherwise cause all channels to record until the fault clears or the record-length timer setting is exceeded.

The transient fault recorder shall have facility for suitable interface for transmission of recorded analog and digital information to a remote station. This shall be demonstrated by the TSP at site by using inter-station communication.

(iii) Input Circuitry

The input circuits for the recording channels shall be insulated for operation at potentials of 2000 Vrms between channels and between channel and ground. Each input recording channel shall be capable of operating from the output of 1A rms nominal secondaries of current transformers and capacitive voltage transformers with 63.5 V rated secondary. Each channel shall be supplied with a selection of current shunts and voltage multipliers to provide a range of high and low current or voltage ranges which can be selected by straps or similar method. The recorder shall also be capable of operating from the DCCT's and direct voltage devices supplied for the station. Any device required for processing of input signals in order to make them compatible to the equipment shall form an integral part of the supplied equipment. However, such processing of input signals shall in no way distort its waveform. The equipment shall be carefully screened, shielded, earthed and protected as may be required for its safe functioning. It shall be possible to position the reference point of any of the analog channels to any position on the record. The individual traces shall be identified on the record by numbering them in the order they are connected at the input.

The current values of scaling parameters related to the various channels shall be printed on each printout to enable quick interpretation of the records.

(iv) Starting Sensors

Transmission Service Agreement

The initiating or detecting devices, which start the recording, shall be solid state and automatic self-resetting type.

Each sensor shall be equipped with an indicating lamp, viewable from the front of the cabinet, which operates when the sensor operates. The lamp shall remain 'on' until reset by the station operator. Failure to reset the lamp shall not affect subsequent operation of the sensor. Sensor settings shall be easily adjustable and easily accessible. One starting sensor for at least each of the following types of changes shall be provided.

- Level Changes Over Current Over Voltage Under voltage
- Swing Rate of change of nominal input
- Frequency
- Under frequency
- Over frequency

It shall be possible to adjust the response time of the sensors, in each case, to ensure the most rapid operation consistent with the characteristics of the analogue quantity being monitored.

It shall also be possible to initiate the fault recording, as required, by additional external relay contacts, either NO or NC.

(v) Pre-fault Periods

The recording system shall accurately record power system transient disturbances with a pre-fault period, which shall be settable between 50 to 250 ms.

(vi) Memories

Sufficient memory shall be provided to prevent any loss of records under all normal operating circumstances.

(vii) Time

A means shall be provided to record on the chart the time of occurrence of each fault or disturbance to a resolution of 2 milliseconds or better. The time clock shall be synchronized with the station master clock signal. Facility shall exist to display the time in hour, minutes and seconds on the front of the panel.

(viii) Calibrations

The recording system shall be so designed that each channel may be calibrated separately. Calibration shall be accomplished by applying the calibration level input in the test switches. Controls and switches shall be provided on the front panel to facilitate calibration.

(ix) Resolutions

Transmission Service Agreement

a) Analog resolution

Analog to digital conversion shall be 12 bits (minimum). The amplitude of the recording shall be adjustable and magnification in fixed steps, of the recording, shall be provided.

b) Events Resolution

The event resolution at the lowest scan rate shall be two milliseconds or better.

c) Transient Response (analog channels)

The transient response delay of the analog input conditioning circuits to a step function input shall be less than 400 microseconds between 10% and 90% values of the step function with overshoot of the final value of the step function being not more than 2%.

(x) Recording Quality

Static trace width	1.5 mm maximum
Residual channel noise	0.1% of full-scale maximum at 50 Hz or any harmonic thereof
Recording resolution	0.1% of full scale
Phase error between channels	Less than 5 degrees at 50 Hz
Crosstalk	Lower than 50 dB (DC to 1500 Hz)

Scale alteration/ expansion facilities shall be provided.

(xi) Alarm Circuits and Indicators

Alarm circuits shall be provided to indicate inability for automatic operation due to power failure, out of paper condition, incorrect switch positioning or other failure(s), which shall be prominently visible on the recorder panel. Each alarm circuit shall include a normally open contact which shall be integrated into the station alarm monitoring and reporting system.

(xii) Power Requirements

The recording system shall be suitable for operation from the station battery supply. There shall be no loss of accuracy in the recording system for specified variations of DC input voltage.

Transient fault recorders should be compatible with IEC 61000-4-30 Class A in order to check compatibility with Grid Connectivity requirements over and above the requirements given below. It should also be compatible for checking DC harmonic performance values. Most stringent of requirements defined above should be considered.

Transmission Service Agreement

DEFINITIONS

OUTAGE TERMS

1. Outage

The state in which equipment or a unit of equipment is unavailable for normal operation due to an event directly related to the same equipment or some unit of equipment.

2. Scheduled Outage

Scheduled outage is an outage which can be scheduled at least one week in advance. This includes planned maintenance, normally conducted on annual basis, and also unplanned maintenance or repair which can be deferred at least one week subsequent to discovery of the need for maintenance or repair. If the outage is extended due to additional work which would have otherwise caused a forced outage, the excess period is counted as a forced outage.

3. Forced Outage

The state in which equipment is unavailable for normal operation, but is not in the scheduled outage state, i.e. an outage which is not a scheduled outage.

4. Pole Outages

An outage which causes a reduction in the Bipole DC power system transfer capacity equal to or less than the power rating of one pole

5. Bipole Outages

An outage which causes a reduction in the bipolar DC system power transfer capacity greater than the power rating of one pole

CAPACITY TERMS

1. Maximum Continuous Capacity (Pm)

Transmission Service Agreement

The maximum bipolar HVDC system capacity (MW) for which continuous operation under normal conditions is possible referred on to the rectifier DC bus, i.e. 2500 MW.

2. Outage Capacity (Po)

The capacity reduction in MW which the outage would have caused if the HVDC system were operating at its maximum continuous capacity (Pm) at the time of the outage.

3. Outage Derating Factor (ODF)

The ratio of outage capacity (Po) to maximum continuous capacity (Pm). $ODF = Po/Pm$

OUTAGE DURATION TERMS

1. Actual Outage Duration (AOD)

The time elapsed in hours between the start and the end of an outage. The time shall be counted to the nearest 1/10th of an hour. Time less than 1/10 of an hour shall be counted as having duration of 1/10 of an hour.

2. Equivalent Outage Duration (EOD)

The actual outage duration (AOD) in hours, multiplied by the outage derating factor (ODF), so as to take account of partial loss of capacity.

$$EOD = AOD \times ODF$$

Each equivalent outage duration may be classified according to the type of outage involved, i.e. equivalent forced outage duration (EFOD) and equivalent scheduled outage duration (ESOD).

TIME CATEGORIES

1. Period Hours (PH)

The number of hours in the reporting period.

Transmission Service Agreement

In a full year the Period Hours are 8760 h (8784 h for a leap year). If the equipment is commissioned part way through a year the period hours shall be proportionately less than 8760 h. (This shall not be applicable for verification of guarantees).

2. Actual Outage Hours (AOH)

The sum of actual outage durations within the reporting period

$$\text{AOH} = \sum \text{AOD}$$

The actual outage hours (AOH) may be classified according to the type of outage involved, i.e. AFOH and ASOH.

3. Equivalent Outage Hours (EOH)

The sum of all equivalent outage durations within the reporting period.

$$\text{EOH} = \sum \text{EOD}$$

The equivalent outage hours may be classified according to the type of outage involved, i.e. equivalent forced outage hours (EFOH) and equivalent scheduled outage hours (ESOH).

If outage duration overlaps the beginning or end of a reporting period, only the EOD which lie within the reporting period shall be included in EOH.

AVAILABILITY AND RELIABILITY TERMS

1. Energy Unavailability (EU)

Energy unavailability is a measure of the energy which could not have been transmitted due to (scheduled and forced) outages.

$$\text{Energy Unavailability \% (EU)} = \text{EOH/PH} \times 100$$

$$\text{Forced Energy Unavailability \% (FEU)} = \text{EFOH/PH} \times 100$$

$$\text{Scheduled Energy Unavailability \% (SEU)} = \text{ESOH/PH} \times 100$$

2. Energy Availability (EA)

Transmission Service Agreement

A measure of the energy which could have been transmitted except for limitations of capacity due to outages, arising from any cause, either forced or scheduled.

$$\text{Energy Availability \% (EA)} = (100 - \text{EU})$$

3. Energy Utilisation (U)

A factor giving a measure of energy actually transmitted over the system.

$$\text{Energy Utilisation \% (U)} = [\text{Total energy transmitted} / (\text{Pm} \times \text{PH})] \times 100$$

Transmission Service Agreement

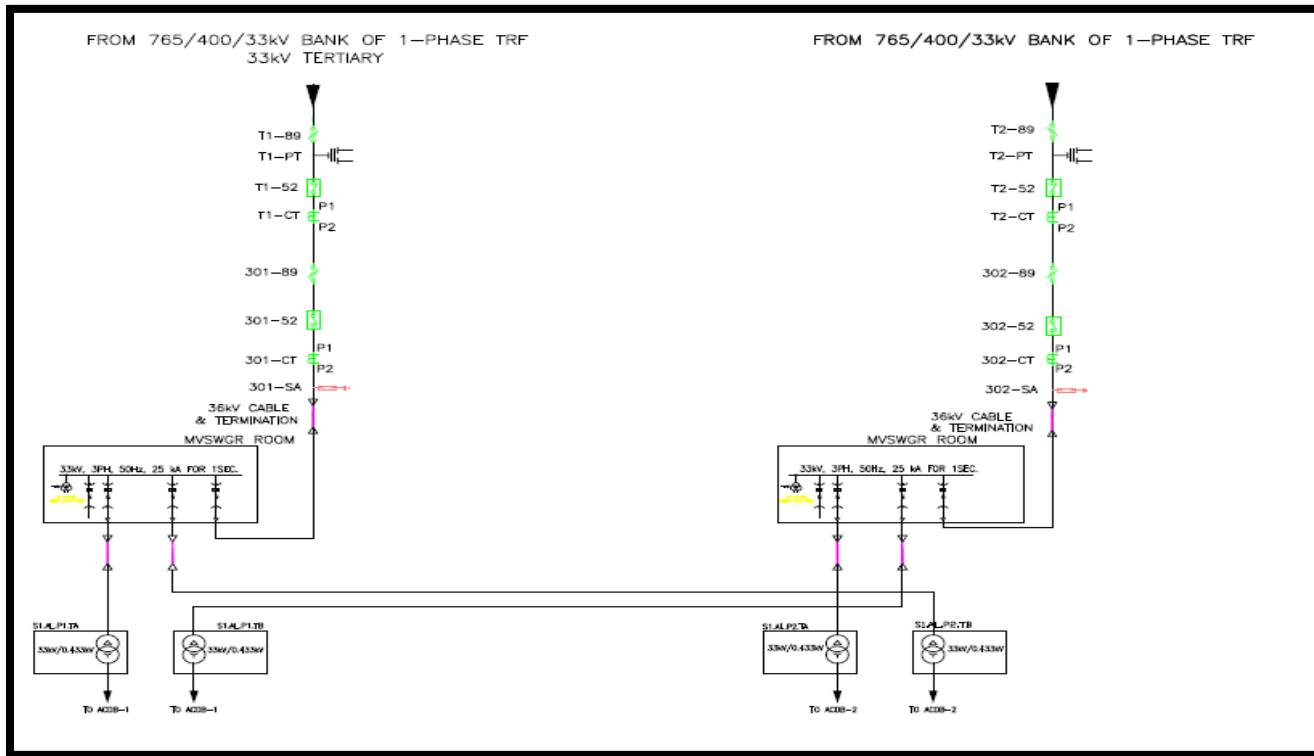

Annexure – E1

SPECIFIC TECHNICAL REQUIREMENTS FOR ± 500 kV HVDC TRANSMISSION LINE

Transmission Service Agreement

- A.1.0 The design, routing and construction of HVDC transmission lines shall be in accordance with CEA (Technical Standards for Construction of Electrical Plants and Electric Lines) Regulations 2022, as amended from time to time. Other CEA Regulations and MoP guidelines, as applicable, shall also be followed.
- A.2.0 Selection of tower type shall be made as per CEA Regulations, however in case lattice type towers are used, the following shall also be applicable:
- A.2.1 Steel section of grade E 250 and/or grade E 350 as per IS 2062, only are permitted for use in towers, extensions, gantry structures and stub setting templates. For towers in snowbound areas, steel sections shall conform to Grade-C of IS-2062.
- A.2.2 Towers shall be designed as per IS-802:2015, however the drag coefficient of the tower shall be as follows: -

Solidity Ratio	Drag Coefficient
Up to 0.05	3.6
0.1	3.4
0.2	2.9
0.3	2.5
0.4	2.2
0.5 and above	2.0

- A.3.0 Transmission Service Provider (TSP) shall adopt any additional loading/design criteria for ensuring reliability of the line, if so desired and /or deemed necessary.
- A.4.0 Transmission line shall be designed considering wind zones as specified in wind map given in National Building Code 2016, Vol.1. The developer shall also make his own assessment of local wind conditions and frequent occurrences of high intensity winds (HIW) due to thunderstorms, dust-storms, downburst etc. along the line route and wherever required, higher wind zone than that given in wind map shall be considered for tower design for ensuring reliability of line. Further, for transmission line sections passing within a distance of 50 km from the boundary of two wind zones, higher of the two wind zones shall be considered for design of towers located in such sections.
- A.5.0 Selection of reliability level for design of tower shall be as per CEA Regulation (Technical Standards for Construction of Electrical Plants and Electric Lines) Regulations 2022, as amended from time to time.
- A.6.0 A) For power line crossing of 400 kV or above voltage level (if crossed over the existing line), large angle and dead-end towers (i.e. D/DD/QD) shall be used on either side of power line crossing.
- B) For power line crossing of 132 kV and 220 kV (or 230 kV) voltage level, angle towers

Transmission Service Agreement

(B/C/D/DB/DC/DD/QB/QC/QD) shall be used on either side of power line crossing depending upon the merit of the prevailing site condition and line deviation requirement.

- C) For power line crossing of 66 kV and below voltage level, suspension/tension towers shall be provided on either side of power line crossing depending upon the merit of the prevailing site condition and line deviation requirement.
- D) For crossing of railways, national highways and state highways, the rules/regulations of appropriate authorities shall be followed.

A.7.0 The relevant conductor configuration shall be as follows: -

- i. Type of conductor: ACSR / AAAC / AL59

Basic parameters for Transmission Line associated with HVDC Bipole link:

Transmission line	ACSR Conductor specified	AAAC conductor based on 53 % conductivity of AL Alloy (Size as per IEC-1089)	Minimum size of AL59 conductor based on 59% conductivity of AL Alloy (Size as per Swedish -SS-420814)	Sub-conductor Spacing
±500 kV HVDC transmission lines (Quad bundle configuration per pole)	Lapwing: Stranding 45/4.78 mm-Al + 7/3.18 mm-Steel; 38.22 mm diameter; 807.5 mm ² , Aluminium area; Maximum DC Resistance at 20°C (Ω/km): 0.0358; Minimum UTS: 188.0 kN	Stranding details: 61/4.38mm, 39.5 mm diameter; 921 mm ² Aluminium alloy area; Maximum DC Resistance at 20°C (Ω/km): 0.0361; Minimum UTS: 244.0 kN	Stranding details: 61/4.36mm, 39.2 mm diameter; 910 mm ² Aluminium alloy area; Maximum DC Resistance at 20°C (Ω/km): 0.0326; Minimum UTS: 199.0 kN	457 mm

Note: The transmission lines shall have to be designed for a maximum operating conductor temperature of 85 deg C.

A.8.0 The required pole to pole spacing shall be governed by the tower design as well as minimum live metal clearances under different insulator swing angles. However, pole to pole clearance shall not be less than 12.5 m.

Transmission Service Agreement

A.9.0 All electrical clearances including minimum live metal clearance, ground clearance and minimum mid span separation between earth wire and conductor as given below shall be considered:

1) Minimum live metal clearances for ± 500 kV line:

a.(i) Swings and Clearances:

Wind Pressure Condition	Minimum Electrical Clearance
a) Swing angle (0°)	3.75 m

(ii) Swings and Clearances: For Jumper

Wind Pressure Condition	Minimum Electrical Clearance
a) Swing angle (0°)	3.75 m
b) Swing angle (15°)	3.15 m
c) Swing angle (57°)	1.1 m

(b) Minimum ground clearance: 12.5 m

c) Minimum mid span separation between earthwire and Pole conductor: 9.0 m

A.10.0 Shielding angle shall not exceed 10 deg for Pole.

A.11.0 Two numbers of Dedicated Metallic Return (DMR) line shall be provided for the ± 500 kV HVDC transmission line. Design and selection of conductor of DMR shall be done by the TSP based on sound engineering practice, minimum power losses, meeting the statutory clearances and other technical requirement of RfP.

A.12.0 At least one out of two earth wires shall be OPGW and second earth wire, if not OPGW, shall be either of Galvanized Stranded Steel (GSS) or Aluminum Alloy Conductor Steel Reinforced (AACSR) or any other suitable conductor type depending upon span length and other technical consideration. However, minimum size of Galvanized Stranded Steel (GSS) shall be 7/4.5 mm and diameter 13.50 mm.

A.13.0 Each tower shall be earthed such that tower footing impedance does not exceed 10 ohms. Pipe type or Counterpoise type earthing shall be provided in accordance with relevant IS. Additional earthing shall be provided on every 7 to 8 km distance for direct earthing of both shield wires. If site condition demands, multiple earthing or use of earthing enhancement compound shall be used.

A.14.0 Pile type foundation shall be used for towers located in river or creek bed or on bank of river having scourable strata or in areas where river flow or change in river course is anticipated, based on detailed soil investigation and previous years' maximum flood

Transmission Service Agreement

discharge of the river, maximum velocity of water, highest flood level, scour depth and anticipated change in course of river based on river morphology data of at least past 20 years to ensure availability and reliability of the transmission line.

A.15.0 Transmission line route shall be finalized, in consultation with appropriate authorities so as to avoid the habitant zones of endangered species and other protected species. Bird diverters, wherever required, shall be provided on the line. In order to optimize the route use of GATISHAKTI platform shall also be made.

A.16.0 The transmission lines shall be designed with porcelain/glass/ Composite Insulators as per site pollution severity level in the concerned area. However, minimum creepage distance and insulator length shall be as per follows:

Sl. No.	Description	Type of Insulator	Insulator for ± 500 kV HVDC Transmission Lines
1.	Minimum Creepage Distance for both Light and medium as well as for Heavy and very heavy pollution level	Composite Insulator	27500 mm
	Minimum Creepage Distance for Light and medium pollution level	Porcelain/Glass Insulator	22345 mm
2.	Minimum length of insulator	Composite/ Porcelain/Glass Insulator	6970 mm

A.17.0 Wherever, transmission lines are passing through cyclone prone areas i.e. areas upto 60 km from coast following shall also be applicable:

- a) Terrain category-I, with terrain roughness factor (K2) of 1.08 shall be considered for tower design.
- b) Importance factor for cyclonic region (K4) of 1.3 shall be considered for tower design.
- c) The number of consecutive spans between the section points/ angle point shall not exceed 10 spans or 3km instead of conventional practice of 15 spans or 5km, in order to reduce the failure of such towers in coastal areas due to cascading effect. The section shall be terminated with tension tower/ angle tower and angle of deviation should be based on the site requirement.

A.18.0 Wherever, transmission lines are passing through cyclone prone areas (i.e. areas upto 60 km from coast)/ creek regions/ aggressive soil areas following shall also be applicable:

- d) The fabricated tower parts and stubs shall have a minimum overall zinc coating of

Transmission Service Agreement

900 g/m² of surface area except for plates and sections below 5 mm thickness which shall have a minimum overall zinc coating of 610 g/m² of surface area. The average zinc coating for all sections and plates of 5 mm and above thickness shall be maintained as 127 microns and that for plates and sections below 5 mm shall be maintained as 87 microns.

- e) Ready mix concrete of M30 Grade shall be used to avoid use of locally available saline water. However, design mix concrete of M30 Grade conforming to IS 456 with potable water can be used at locations where transportation of ready-mix concrete is not feasible. Minimum cement content in any case shall not be less than 330 kg/m³.
- f) The surface of the reinforced steel shall be treated with epoxy-based coating to enhance corrosion performance of foundation. Use of epoxy coated reinforcement in foundation shall be as per IS 13620. In addition, two (2) coats of bituminous painting of minimum 1.6 kg/m² per coat shall be applied on all exposed faces of foundation (i.e. pedestal and base slab).
- g) Double coat of 20 mm thick cement plaster shall be provided on all exposed concrete surface up to 300 mm below ground level to give protection to concrete surface from environmental and saline effect.
- h) Before coping of chimney top portion, three coats of anti-corrosive paint of minimum 30-35 microns dry film thickness each shall be applied on the stub in the 50 mm coping portion as well as up to 350 mm above CL portion.

A.19.0 The raised chimney foundation is to be provided in areas prone to flooding/water stagnation like paddy field /agricultural field and undulated areas to avoid direct contact of water with steel part of tower. The top of the chimney of foundation should be at least above HFL (High Flood Level) or the historical water stagnation/ logging level (based on locally available data) or above High Tide Level or 500 mm above Natural Ground level (whichever is higher).

A.20.0 The TSP shall abide by the Guidelines of CEA w.r.t. shifting of transmission lines for NHAI projects and other projects.

A.21.0 Safety precautions in regard to gas/oil pipelines in vicinity of Transmission lines shall be taken in coordination with gas/ petroleum authorities.

SPECIFIC TECHNICAL REQUIREMENTS FOR HVAC TRANSMISSION LINE

- A.1.0 The design, routing and construction of transmission lines shall be in accordance with Chapter V, Part A of CEA (Technical Standards for Construction of Electrical Plants and Electric Lines) Regulations 2022, as amended from time to time. Other CEA Regulations and MoP guidelines, as applicable, shall also be followed.
- A.2.0 Selection of tower type shall be made as per CEA Regulations, however in case lattice type towers are used, the following shall also be applicable:
- A.2.1 Steel section of grade E 250 and/or grade E 350 as per IS 2062, only are permitted for use in towers, extensions, gantry structures and stub setting templates. For towers in snowbound areas, steel sections shall conform to Grade-C of IS-2062.
- A.2.2 Towers shall be designed as per IS-802:2015, however the drag coefficient of the tower shall be as follows: -

Solidity Ratio	Drag Coefficient
Up to 0.05	3.6
0.1	3.4
0.2	2.9
0.3	2.5
0.4	2.2
0.5 and above	2.0

- A.3.0 Transmission Service Provider (TSP) shall adopt any additional loading/design criteria for ensuring reliability of the line, if so desired and /or deemed necessary.
- A.4.0 Transmission line shall be designed considering wind zones as specified in wind map given in National Building Code 2016, Vol.1. The developer shall also make his own assessment of local wind conditions and frequent occurrences of high intensity winds (HIW) due to thunderstorms, dust-storms, downburst etc along the line route and wherever required, higher wind zone than that given in wind map shall be considered for tower design for ensuring reliability of line. Further, for transmission line sections passing within a distance of 50 km from the boundary of two wind zones, higher of the two wind zones shall be considered for design of towers located in such sections.
- A.5.0 Selection of reliability level for design of tower shall be as per CEA Regulation (Technical Standards for Construction of Electrical Plants and Electric Lines) Regulations 2022, as amended from time to time.

Transmission Service Agreement

- A.6.0 A) For power line crossing of 400 kV or above voltage level, large angle and dead-end towers (i.e. D/DD/QD) shall be used on either side of power line crossing.
- B) For power line crossing of 132 kV and 220 kV (or 230 kV) voltage level, angle towers (B/C/D/DB/DC/DD/QB/QC/QD) shall be used on either side of power line crossing depending upon the merit of the prevailing site condition and line deviation requirement.
- C) For power line crossing of 66 kV and below voltage level, suspension/tension towers shall be provided on either side of power line crossing depending upon the merit of the prevailing site condition and line deviation requirement.
- D) For crossing of railways, national highways and state highways, Regulations of appropriate authorities shall be followed.

A.7.0 The relevant conductor configuration shall be as follows: -

Name : KPS3 – KPS3 (HVDC) 400 kV 2xD/C Line

Type of conductor: ACSR / AAAC / AL59

Basic parameters:

Transmission line	ACSR Conductor specified	Equivalent AAAC conductor based on 53% conductivity of Al Alloy	Equivalent minimum size of AL59 conductor based on 59% conductivity of AL Alloy*	Sub-conductor Spacing
400 kV D/C (Quad Bundle) transmission lines	<p>Moose: Stranding 54/3.53mm-Al + 7/3.53 mm-Steel;</p> <p>31.77 mm diameter;</p> <p>528.5 mm², Aluminium area;</p> <p>Maximum DC Resistance at 20°C (Ω/km): 0.05552;</p> <p>Minimum UTS: 161.20 kN</p>	<p>Stranding details: 61/3.55mm</p> <p>31.95mm diameter;</p> <p>604 mm² Aluminium alloy area;</p> <p>Maximum DC Resistance at 20°C (Ω/km): 0.05506;</p> <p>Minimum UTS: 159.80 kN</p>	<p>Stranding details: 61/3.31 mm</p> <p>29.79 mm diameter;</p> <p>525 mm² Aluminium alloy area;</p> <p>Maximum DC Resistance at 20°C (Ω/km): 0.0566;</p> <p>Minimum UTS: 124.70 kN</p>	457 mm

Note:

1. **To select any size above the minimum, the sizes mentioned in the Indian standard i.e IS-398(part-6) should be followed.*
2. *The transmission lines shall have to be designed for a maximum operating conductor temperature of 85 deg C.*

A.8.0 The required phase to phase spacing and horizontal spacing for 400 kV line shall be governed by the tower design as well as minimum live metal clearances for 400 kV voltage level under different insulator swing angles. However, the phase to phase spacing for 400 kV lines shall not be less than 8 m respectively.

A.9.0 All electrical clearances including minimum live metal clearance, ground clearance and minimum mid span separation between earth wire and conductor as given below shall be considered.

Minimum live metal clearances for 400 kV line:

- i. a). Under stationary conditions:

From tower body: 3.05 m

- b). Under Swing conditions

Wind Pressure Condition	Minimum Electrical Clearance
a) Swing angle (22°)	3.05 m
b) Swing angle (44°)	1.86 m

- ii. Minimum ground clearance for 400 kV: 8.84 m
- iii. Minimum mid span separation between earth-wire and conductor for 400 kV line: 9.0 m

A.10.0 Shielding angle shall not exceed 20 deg for 400 kV transmission line.

A.11.0 The Fault current for design of line shall be 63 kA for 1 sec for 400 kV.

A.12.0 In case of 400 kV voltage class lines, at least one out of two earth wires shall be OPGW and second earth wire, if not OPGW, shall be either of Galvanized Stranded Steel (GSS) or Aluminum Alloy Conductor Steel Reinforced (AACSR) or any other suitable conductor type depending upon span length and other technical consideration.

A.13.0 Each tower shall be earthed such that tower footing impedance does not exceed 10 ohms. Pipe type or Counterpoise type earthing shall be provided in accordance with relevant IS. Additional earthing shall be provided on every 7 to 8 km distance at tension tower for

Transmission Service Agreement

direct earthing of both shield wires. If site condition demands, multiple earthing or use of earthing enhancement compound shall be used.

- A.14.0 Pile type foundation shall be used for towers located in river or creek bed or on bank of river having scourable strata or in areas where river flow or change in river course is anticipated, based on detailed soil investigation and previous years' maximum flood discharge of the river, maximum velocity of water, highest flood level, scour depth and anticipated change in course of river based on river morphology data of at least past 20 years to ensure availability and reliability of the transmission line.
- A.15.0 Transmission line route shall be finalized, in consultation with appropriate authorities so as to avoid the habitant zones of endangered species and other protected species. Bird diverters, wherever required, shall be provided on the line. In order to optimize the route use of GATISHAKTI platform shall also be made.
- A.16.0 Wherever, transmission lines are passing through cyclone prone areas i.e. areas upto 60 km from coast following shall also be applicable:
- a) Terrain category-I, with terrain roughness factor (K2) of 1.08 shall be considered for tower design for exposed open terrain with few or no obstruction which also includes open sea coasts, open stretch of water, desert and flat treeless plains.
 - b) Importance factor for cyclonic region (K4) of 1.3 shall be considered for tower design.
 - c) The number of consecutive spans between the section points/ angle point shall not exceed 10 spans or 3 km instead of conventional practice of 15 spans or 5 km, in order to reduce the failure of such towers in coastal areas due to cascading effect. The section shall be terminated with tension tower/ angle tower and angle of deviation should be based on the site requirement.
- A.17.0 Wherever, transmission lines are passing through cyclone prone areas (i.e. areas up to 60 km from coast)/ creek regions/ aggressive soil areas following shall also be applicable:
- a) The fabricated tower parts and stubs shall have a minimum overall zinc coating of 900 g/m^2 of surface area except for plates and sections below 5 mm thickness which shall have a minimum overall zinc coating of 610 g/m^2 of surface area. The average zinc coating for all sections and plates 5 mm and above thickness shall be maintained as 127 microns and that for plates and sections below 5 mm thickness shall be maintained as 87 microns.
 - b) Ready mix concrete of M30 Grade shall be used to avoid use of locally available saline water. However, design mix concrete of M30 Grade conforming to IS 456 with potable water can be used at locations where transportation of ready-mix concrete is not feasible. Minimum cement content in any case shall not be less than 330 kg/m^3 .
 - c) The surface of the reinforced steel may be treated with epoxy-based coating to

Transmission Service Agreement

enhance corrosion performance of foundation. Use of epoxy coated reinforcement in foundation shall be as per IS 13620. In addition, two (2) coats of bituminous painting of minimum 1.6 kg/m² per coat shall be applied on all exposed faces of foundation (i.e. pedestal and base slab).

- d) Double coat of 20 mm thick cement plaster shall be provided on all exposed concrete surface up to 300 mm below ground level to give protection to concrete surface from environmental and saline effect.
 - e) Before coping of chimney top portion, three coats of anti-corrosive paint of minimum 30-35 microns dry film thickness each shall be applied on the stub in the 50mm coping portion as well as up to 350 mm above CL portion.
- A.18.0 The raised chimney foundation is to be provided in areas prone to flooding/water stagnation like paddy field /agricultural field and undulated areas to avoid direct contact of water with steel part of tower. The top of the chimney of foundation should be at least above HFL (High Flood Level) or the historical water stagnation/ logging level (based on locally available data) or above High Tide Level or 500 mm above Natural Ground level (whichever is higher).
- A.19.0 Routing of transmission line through protected areas of India shall be avoided to the extent possible. In case, it is not possible to avoid protected areas, the towers of the transmission line up to 400 kV level which are installed in protected areas shall be designed for Multi-circuit (4 circuits) configuration of same voltage level considering reliability level of at least two (2). The top two circuits of these multi-circuit towers shall be used for stringing of the transmission line under present scope and the bottom two circuits shall be made available for stringing of any future transmission line of any transmission service providers/ State transmission utilities/Central transmission utilities passing through the same protected area. Further, the configuration and coordinates of such transmission towers shall be submitted to CEA, CTU and BPC by the TSP.
- A.20.0 The TSP shall abide by the Guidelines of CEA w.r.t. shifting of transmission lines for NHAI projects and other projects.
- A.21.0 Safety precautions in regards to gas/oil pipe lines in vicinity of transmission lines shall be taken in coordination with gas/ petroleum authorities.

SPECIFIC TECHNICAL REQUIREMENTS FOR HVAC EQUIPMENT

The 400 kV switchyard at **KPS3 (HVDC) S/s, extension of KPS3 S/s and extension of South Olpad S/s** shall be GIS type generally conforming to the requirements of CEA (Technical Standards for Construction of Electrical Plants and Electric Lines) Regulations 2022 as amended from time to time.

All other CEA Regulations/guidelines as amended up to date and MoP guidelines shall also be followed.

B.1.0 Salient features of Substation Equipment and Facilities

The design and specification of substation equipment are to be governed by the following factors:

B.1.1 Insulation Coordination

The system design parameters for substations/switchyards shall be as given below:

Sl. No.	Description of parameters	400 kV KPS3 (HVDC) / KPS3 GIS Extn.	400 kV South Olpad GIS Extn
		400 kV System	400 kV System
1.	System operating voltage	400 kV	400 kV
2.	Maximum voltage of the system (rms)	420 kV	420 kV
3.	Rated frequency	50 Hz	50 Hz
4.	No. of phases	3	3
5.	Rated Insulation levels		
i)	Lightning Impulse withstand voltage for (1.2/50 micro sec.) for Equipment other than Transformer and Reactor for Insulator String	1425 kV p	1425 kV p
		1550 kV p	1550 kV p
ii)	Switching impulse withstand voltage (250/2500 micro sec.) dry and wet	1050 kV p	1050 kV p
iii)	One-minute power frequency dry withstand voltage (rms)	650 kV	650 kV
6.	Corona extinction voltage	320 kV	320 kV

Transmission Service Agreement

Sl. No.	Description of parameters	400 kV KPS3 (HVDC) / KPS3 GIS Extn.	400 kV South Olpad GIS Extn
		400 kV System	400 kV System
7.	Max. radio interference voltage for frequency between 0.5 MHz and 2 MHz	1000 micro-volts at 266 kV rms	1000 micro-volts at 266 kV rms
8.	Minimum creepage distance for insulator string/ longrod insulators/ outdoor bushings	13020 mm (31 mm/ kV)	13020 mm (31 mm/ kV)
9.	Minimum creepage distance for switchyard equipment	13020 mm (31 mm/ kV)	13020 mm (31 mm/ kV)
10.	Max. fault current	63 kA	63 kA
11.	Duration of fault	1 Sec	1 Sec

B.1.2 Switching Scheme

The switching schemes, as mentioned below, shall be adopted at various voltage levels of substation/switchyard:

Substation	400 kV side
400 kV KPS3 (HVDC)	One and Half breaker
400 kV KPS3 Extn	One and Half breaker
400 kV South Olpad Extn.	One and Half breaker

Notes: -

- i) *For one and half breaker switching scheme, any double circuit line consisting of two numbers of feeders and originating from the same transmission or generating switchyard shall not be terminated in one diameter.*
- ii) *Two transformers of the same HV rating shall not be connected in the same diameter and similarly, two bus reactors of same HV rating shall also not be connected in the same diameter.*
- iii) *A diameter in one and half breaker scheme is a set of 3 circuit breakers with associated isolators, earth switches, current transformers etc for controlling of 2 numbers of feeders.*
- iv) *TSP shall plan distribution of line and transformer feeders to bus bar in such a way that all power can be evacuated successfully without crossing thermal limit at any point of bus-bar.*

Transmission Service Agreement

- v) *400 kV Bus Sectionaliser shall be placed such that each section shall have proper distribution of Pole(s), ICT, Feeders and filter bank(s)/sub-bank(s) so as to have maximum operational flexibility.*
- vi) *In case of GIS substation where the bus scheme is One and Half breaker scheme, the diameters shall be complete with feeder/line side isolator and GIS duct of the future bay shall be brought outside the GIS hall/building with extension/interface module suitably.*

B.2.0 Substation

Equipment and facilities (Voltage level as applicable):

The switchgear shall be designed and specified to withstand operating conditions and duty requirements. All equipment shall be designed considering the following minimum capacity.

Sl. No.	Description of bay	Ampacity		
		400 kV KPS3 (HVDC) GIS S/s	400 kV KPS3 GIS Extn	400 kV South Olpad GIS Extn
		400 kV	400 kV	400 kV
1.	Bus Bar	4000 A	4000A	4000A
2.	Line bay	3150 A	3150A	--NA--
3.	Converter bay	3150 A	--NA--	3150 A
3.	ICT bay	3150 A	--NA--	--NA--
4.	Bus Reactor bay	3150 A	--NA--	--NA--
5.	Bus Sectionaliser bays	4000 A	--NA--	--NA--

B.2.1 400/33 kV, 50 MVA Transformers [for exclusively supplying auxiliary power to HVDC terminal]

50 MVA, 400/33 kV, 3-Phase Transformers shall conform to CEA's "Standard Specifications and Technical Parameters for Transformers and Reactors (66 kV and above voltage class)" available on CEA website.

B.2.2 420 kV, 3-Phase, Shunt Reactor

125 MVAR, 420 kV, 3-Phase Reactor shall conform to CEA's "Standard Specifications and Technical Parameters for Transformers and Reactors (66 kV and above voltage class)" as amended up to date available on CEA website.

B.2.3 400 kV GIS Substation equipment

Transmission Service Agreement

GIS (Gas Insulated Switchgear) shall be Indoor type in accordance to IEC: 62271-203. The switchgear shall be designed and specified to withstand operating conditions and duty requirements. All the switchgear such as Circuit Breaker, isolator, earth switch including CT, PT etc. shall be GIS type. The Surge Arrestor and Voltage Transformer shall be either GIS or outdoor AIS type.

The GIS assembly shall consist of separate modular compartments e.g. Circuit Breaker compartment, Bus bar compartment filled with SF6 Gas and separated by gas tight partitions so as to minimize risk to human life, allow ease of maintenance and limit the effects of gas leaks failures and internal arcs etc. These compartments shall be designed to minimize the risk of damage to adjacent sections and protection of personnel in the event of a failure occurring within the compartments. Rupture diaphragms with suitable deflectors shall be provided to prevent uncontrolled bursting pressures developing within the enclosures under worst operating conditions, thus providing controlled pressure relief in the affected compartment. The arrangement of gas sections or compartments shall be such as to facilitate future extension of any make without any drilling, cutting or welding on the existing equipment. To add equipment, it shall not be necessary to move or dislocate the existing switchgear bays. The layout of Gas Insulated Bus Ducts shall be properly planned to optimize the length of bus ducts and for easy accessibility for maintenance. The length of busbars, bus ducts, isolator sections shall be optimized considering effects of fast transient voltage due to isolator operations.

The bus bar modules including auxiliary bus modules (wherever applicable) shall be provided with suitable End Piece (Interface) module on both sides with the test link facility for future extension as per provisions of future requirement. The end piece module shall be designed in such a way so that future GIS module may be tested without extending test voltage to existing bus and vice-versa by removing the test link.

TSP shall make available the complete details for the design of interface module such as cross section, enclosure material, enclosure dimensions (inner and outer), Flange diameter (inner and outer), conductor cross-section and connection arrangement, bolt spacing and dimension, rated gas pressure, Gasket detail etc. Further, adequate space for GIS busbar interface module shall be taken into account for future scope.

Each section shall have plug-in or easily removable connection pieces to allow for easy replacement of any component with the minimum disturbance to the remainder of the equipment. Inspection windows (View Ports) shall be provided for Disconnect Switches and both type of earth switches i.e. Maintenance and fast operating.

Local control cabinets (LCC) shall be provided as per requirement. The alarm and annunciation of GIS equipment shall be wired to the SCADA System.

Transmission Service Agreement

The material and thickness of the enclosures shall be such as to withstand an internal flash over without burns through for a period of 300 ms at rated short time withstand current. The material shall be such that it has no effect of environment as well as from the by-products of SF6 breakdown under arcing conditions. This shall be validated with Type Test.

Service continuity requirement for GIS:

The GIS equipment with the given bus switching arrangement shall be divided into different gas compartments. During the work such as a fault repair or major maintenance, requiring the dismantling of a gas compartment for which more than one compartments may need to be de-gassed.

TSP shall meet the following Service continuity conditions (to the extent possible) with ensuring equipment and operating personnel's safety:

- For One and half breaker bus switching scheme, during a fault in Circuit Breaker compartment, no bus bar and feeder is permitted out of service during maintenance and repair/replacement.
- During a fault in a GIS compartment other than the Circuit Breaker compartment, maximum of one bus bar and/or one feeder is permitted out of service during maintenance and repair/replacement.

UHF sensors in GIS for PD (Partial Discharge) detection:

The adequate number of Ultra High frequency (UHF) sensors shall be provided in the offered GIS along with suitable portable type Partial Discharge (PD) measuring instrument for detection of Partial discharge (of 5 pC and above as per IEC 60270). The number and location of these sensors shall be based on laboratory tests on the typical design of GIS as per recommendations of CIGRE Document No. 654 (Application Guide for sensitivity verification for UHF Partial discharge detection system for GIS).

B.2.3.1 Circuit Breakers (GIS)

GIS Circuit breakers shall in general be of C2-M2 class and comply with IEC-62271-100. The rated break time shall not exceed 40 ms (milli second) for 400 kV. Circuit breakers shall be suitable for single phase and three phase auto reclosing. Each breaker shall have two sets of trip circuits which would be connected to separate DC supplies for greater reliability. The Circuit breakers controlling 400 kV lines wherever required shall be provided with pre-insertion closing resistor of about 400 ohms with 8 ms insertion time or Controlled Switching Device (CSD) for lines longer than 200 km. The short line fault capacity shall be same as the rated capacity and this is proposed to be achieved without use of opening

resistors. Controlled switching device shall be provided in Circuit Breaker of switchable line reactor bay and in 400 kV and above Main and Tie bay circuit breakers of line with non-switchable line reactors, Bus reactors and Transformers.

B.2.3.2 Isolators (GIS)

The isolators shall comply with IEC 62271-102 in general. Earth switches shall be provided at various locations to facilitate maintenance. Main blades and earth blades shall be interlocked and interlock shall be fail safe type. All isolators and earth switches shall be motor operated type.

Isolator shall be of extended mechanical endurance class-M2 and suitable for Bus Transfer Current Switching duty as per IEC standard. High speed earthing switches shall be provided for grounding purpose at overhead line terminations and cable terminations and shall have fault making capability as specified. Earth switch for line isolator shall be of earthing switch class E1 and shall be suitable for induced current switching duty as defined for Class-B as per relevant standard.

B.2.3.3 Current Transformers (GIS)

Current Transformers shall comply with IEC 61869 in general. All ratios shall be obtained by secondary taps only. Generally, Current Transformers (CT) shall have five cores (four for protection and one for metering) whereas; CT in Tie bays shall have six cores (four for protections and two for metering) suitably distributed on both sides of CB (for 400 kV and above voltage class). The burden and knee point voltage shall be in accordance with the requirements of the system including possible feeds for telemetry. Accuracy class for protection core shall be PX and for metering core it shall be 0.2S. The rated burden of cores shall be closer to the maximum burden requirement of metering and protection system (not more than 20 VA for metering core) for better sensitivity and accuracy.

The instrument security factor shall be less than 5 for CTs up to 400 kV voltage class.

B.2.3.4 Voltage Transformer (GIS)

The voltage transformers shall conform to IEC-61869. Voltage transformers shall be of electromagnetic type with SF6 gas insulation. The earth end of the high voltage winding and the ends of the secondary winding shall be brought out in the terminal box. The voltage transformers shall be located as a separate bay module and will be connected phase to ground and shall be used for protection, metering and synchronization. The voltage transformers shall be of inductive type, nonresistant and shall be contained in their own-SF6 compartment, separated from other parts of installation. The voltage transformer shall be effectively shielded against high frequency electromagnetic

transients. The voltage transformer shall have three secondary windings out of which two shall be used for protection and one for metering. The voltage transformer should be thermally and dielectrically safe when the secondary terminals are loaded with the guaranteed thermal burdens. The accuracy class for protection cores shall be 3P. The accuracy of 0.2 on metering core should be maintained throughout the entire burden range on all the three windings without any adjustments during operation. The rated burden of cores shall be closer to the maximum burden requirement of metering and protection system (not more than 50 VA for metering core) for better sensitivity and accuracy.

B.2.3.5 Surge Arresters (GIS) (if applicable)

336 kV Station High (SH) duty gapless type Surge arresters with thermal energy (Wth) of minimum 12 kJ/kV respectively shall be provided for 420 kV system conforming to IEC 60099-4 in general. Other characteristics of Surge arrester shall be chosen in accordance with system requirements. Surge arresters shall be provided at line entrances, near transformers and reactors so as to achieve proper insulation coordination. A leakage current monitor with surge counter shall be provided with each surge arrester.

B.2.3.6 SF₆ to Air Bushing

Outdoor bushings, for the connection of conventional external conductors to the SF₆ metal enclosed switchgear, shall be provided. Bushings shall generally be in accordance with the requirements of IEC-60137. The creepage distance over the external surface of outdoor bushings shall not be less than 31 mm/kV. SF₆ to air Bushing shall be of Polymer / composite type and shall be robust and designed for adequate cantilever strength to meet the requirement of seismic condition. The electrical and mechanical characteristics of bushings shall be in accordance with IEC-60137. Polymer/composite insulator shall be seamless sheath of silicon rubber compound. The housing and weather sheds should have silicon content of minimum 30% by weight. It should protect the bushing against environmental influences, external pollution and humidity. The hollow silicon composite insulators shall comply with the requirements of IEC 61462 and the relevant parts of IEC-62217.

B.2.4 400 kV AIS Substation equipment (as applicable)

B.2.4.1 Capacitive Voltage Transformers (AIS)/ AC Voltage Transformer/ AC Voltage Divider

Capacitive Voltage transformers/AC Voltage Transformer/ AC Voltage Divider shall comply with IEC 61869 in general. These shall have three secondaries out of which two shall be used for protection and one for metering. The Accuracy class for protection cores shall be 3P and for metering core shall be 0.2. The Capacitive voltage transformers on lines shall

Transmission Service Agreement

be suitable for Carrier Coupling. The Capacitance of CVT for 400 kV shall be of 4400/8800 pF depending on PLCC requirements. The rated burden of cores shall be closer to the maximum burden requirement of metering and protection system (not more than 50 VA for metering core) for better sensitivity and accuracy.

For power quality measurement compatibility, the transducers including its interface with control and protection panels and display like Transient fault recorders should be compatible with IEC 61000-4-30 Class A in order to check compatibility with Grid Connectivity requirements over and above the requirements given above.

B.2.4.2 Surge Arresters (AIS)

336 kV Station High (SH) duty gapless type Surge arresters with thermal energy (Wth) of minimum 12 kJ/ kV conforming to IEC 60099-4 in general shall be provided for 400 kV systems. Other characteristics of the Surge arrester shall be chosen in accordance with system requirements. Surge arresters shall be provided at line entrances, near transformers and reactors so as to achieve proper insulation coordination. Surge Arresters shall be provided with porcelain/ polymer housing fitted with pressure relief devices. A leakage current monitor with surge counter shall be provided with each surge arrester.

B.2.5 Protection Relaying and Control System

The protective relaying system proposed to be provided for transmission lines, auto-transformers, reactors and bus bars to minimize the damage to the equipment in the events of faults and abnormal conditions, is dealt in this section. All main protective relays shall be numerical type with IEC 61850 communication interface and should have interoperability during integration of numerical relays to communicate over IEC61850 protocol with RTU/SAS/IEDs of different OEMs. All numerical relays shall have built in disturbance recording feature.

The protection circuits and relays of transformer and reactor shall be electrically and physically segregated into two groups each being independent and capable of providing uninterrupted protection even in the event of one of the protection groups failing, to obtain redundancy, and to take protection systems out for maintenance while the equipment remains in service.

a) Transmission Lines Protection

400 kV transmission lines shall have Main-I numerical three zone distance protection scheme with carrier aided inter-tripping feature. 400 kV lines shall also have Main-II numerical distance protection scheme like Main-I but from different make that of Main-I.

Transmission Service Agreement

The Main-I and Main-II protection relays of same make may be provided only if they are of different hardware and manufacturing platform or different principle of operation.

However, Line Current Differential relay (with back up distance protection feature) as Main-I and Main-II shall be considered at both ends for short lines (line length below 30 km) having Fibre Optic communication link. Differential relay at remote end shall be provided by the TSP. Associated power and control cabling and integration with SAS at remote end shall be provided by respective bay owner.

Further, all 400 kV lines shall be provided with single and three phase auto-reclosing facility to allow reclosing of circuit breakers in case of transient faults. These lines shall also be provided with distance to fault locators to identify the location of fault on transmission lines.

All 400 kV lines shall also be provided with two stages over voltage protection. Over voltage protection and distance to fault locator may be provided as in-built feature of Main-I and Main-II protection relays. Auto reclose as built-in function of Bay Control Unit (BCU) is also acceptable.

The Main-I and Main-II protection relays shall be fed from separate DC sources and shall be mounted in separate panels.

For 400 kV transmission lines, directional IDMT earth fault relay should be provided as standalone unit or in-built feature of Main-I and Main -II feature.

b) Auto Transformer Protection

These shall have the following protections:

- i) Numerical Differential protection
- ii) Numerical Restricted earth fault protection
- iii) Numerical Back-up Directional Over-current and earth fault protection on High Voltage (HV) and Intermediate Voltage (IV) side
- iv) Numerical Over fluxing protection on HV and IV side
- v) Numerical Overload alarm

Further, Numerical Back-up Over-current and earth fault protection on HV and IV side of autotransformer shall not be combined with other protective functions in the main relays and shall be independent relays. Besides these, power transformers shall also be provided

Transmission Service Agreement

with Buchholz relay, Magnetic Oil Gauge (MOG) with low oil level alarm, protection against high oil and winding temperature and pressure relief device etc.

Suitable monitoring, control (operation of associated circuit breaker and isolator) and protection for LT auxiliary transformer connected to tertiary winding of auto-transformer for the purpose of auxiliary supply shall be provided. The over current and other necessary protection shall be provided for the auxiliary transformer. These protection and control may be provided as built in feature either in the bay controller to be provided for the auxiliary system or in the control and protection IEDs to be provided for autotransformer.

c) **400 kV Reactor Protection**

Reactor shall be provided with the following protections:

- i) Numerical Differential protection.
- ii) Numerical Restricted earth fault protection
- iii) Numerical Back-up impedance protection

Besides these, reactors shall also be provided with Buchholz relay, MOG with low oil level alarm, protection against oil and winding temperatures and pressure relief device, etc.

d) **Bus bar Protection**

The high speed low impedance type bus bar differential protection, which is essential to minimize the damage and maintain system stability at the time of bus bar faults, shall be provided for 400 kV. Duplicated bus bar protection is envisaged for 400 kV bus-bar protection. Bus bar protection scheme shall be such that it operates selectively for each bus and incorporate necessary features required for ensuring security. The scheme shall have complete bus bar protection for present as well as envisaged future bays i.e. input / output modules for future bays shall also be provided.

Bus Bar protection system for new substation shall be de-centralized (distributed) type.

In case, the bus section is provided, then each side of the bus section shall have separate set of bus bar protection schemes.

For existing substations, the existing bus bar protection shall be augmented as per requirement.

e) **Local Breaker Back up Protection**

Transmission Service Agreement

This shall be provided for each 400 kV circuit breakers and will be connected to de-energize the affected stuck breaker from both sides.

Notes:

- 1. LBB and REF relays shall be provided separately from transformer differential relay.*
- 2. LBB relay may also be provided as built-in protection function of distributed bus bar protection scheme; however in such case separate LBB relay shall be provided for tie bays (in case of One and Half breaker scheme).*
- 3. Over fluxing and overload protection can be provided as built-in feature of differential relay.*
- 4. In 400 kV switchyard, if spare bay of half diameter is identified as future, Tie CB relay panel shall be with Auto-reclosure feature.*

B.2.6 Substation Automation System

a) For all the new substations, a state-of-art Substation Automation System (SAS) conforming to IEC-61850 shall be provided. The distributed architecture shall be used for Substation Automation system, where the controls shall be provided through Bay control units. The Bay control unit is to be provided bay-wise for voltage level 400 kV and above. All bay control units as well as protection units are normally connected through an Optical fibre high speed network. The control and monitoring of circuit breaker, dis-connector, re-setting of relays etc. can be done from Human Machine Interface (HMI) in the control room.

The functions of control, annunciation, disturbance recording, event logging and measurement of electrical parameters shall be integrated in the Substation Automation System.

At new substations, the Substation Automation System (SAS) shall be suitable for the operation and monitoring of the complete substation including proposed future bays/elements.

In existing substations with a Substation Automation System (SAS), augmentation of existing SAS shall be done for bays under the present scope.

In existing Substations where Substation automation is not provided, control functions shall be done through control panels.

Necessary gateway and modems (as required) shall be provided to send data to RLDC/SLDC as per their requirement and shall be provisioned with 2+2 redundancy i.e. 2 channels for Main Control Centre and 2 channels for Backup Control Centre. In order to

meet this requirement, suitable redundancy at port and card level need to be ensured by the TSP to avoid any single point of failure which may lead to interruption in real-time grid operation. Accordingly, all the hardware for communication services of station as stated above shall support dual redundancy for data transmission of station to respective main and backup RLDCs. Any augmentation work at RLDC/SLDC is excluded from TSP's scope. However, all the configuration work at substation end required to send data to RLDC/SLDC shall be in the scope of TSP.

b) Time synchronization equipment

Time synchronization equipment complete in all respect including antenna, cable, processing equipment required to receive time signal through GPS or from National Physical Laboratory (NPL) through INSAT shall be provided at new substations. This equipment shall be used to synchronize SAS and IEDs etc.

B.3.0 Substation Support facilities

Certain facilities required for operation and maintenance of substations as described below shall be provided at new substation. In existing substation, these facilities have already been provided and would be extended/ augmented as per requirement.

B.3.1 Fire Fighting System

Fire-fighting system for substation including transformer and reactor shall conform to CEA (Measures Relating to Safety and Electric Supply) Regulations, 2023 as amended time to time.

Further, adequate water hydrants and portable fire extinguishers shall be provided in the substations. The main header of firefighting system shall be suitable for extension to bays covered under the future scope; necessary piping interface in this regard shall be provided.

Optical Beam type heat detection for GIS hall fire protection system shall be provided for all the GIS halls.

At existing substations, the fire-fighting systems, as available, shall be augmented/ extended to meet the additional requirements.

B.3.2 Oil evacuating, filtering, testing and filling apparatus

To monitor the quality of oil for satisfactory performance of transformers, shunt reactors and for periodical maintenance necessary oil evacuating, filtering, testing and filling apparatus would be provided at new substations. Oil storage tanks of adequate capacities for storage of transformer oil would be provided.

Online Transformer Oil Drying Out System shall be provided in line with the provisions of Standard Specification and Technical Parameters for Transformers and Reactors (66 kV and above voltage class) as amended up to date available on CEA website.

B.3.3 Illumination

Normal and emergency AC and DC illumination shall be provided adequately in the control room and other buildings of the substation. The switchyard shall also be provided with adequate illumination.

Lighting of the entire control room building, fire-fighting pump house, other building (if any) and switchyard shall be done by LED based low power consumption luminaires.

B.3.4 Control Room

For new substation, substation control room shall be provided to house substation workstations for station level control (SAS) along with its peripheral and recording equipment, AC and DC distribution boards, DC batteries and associated battery chargers, Fire Protection panels, Telecommunication panels and other panels as per requirements. Air conditioning shall be provided in the building as functional requirements. Main cable trenches from the control room shall have adequate space provision for laying of cables from control room for all the future bays also.

Common control may be constructed for HVDC and HVAC systems.

At existing substations, the adequacy of size of control room shall be ascertained and the same shall be augmented as per requirement.

B.3.5 GIS hall

The Gas Insulated Switchgear (GIS) of each voltage level along with other associated equipment shall be housed inside separate GIS building. The panels i.e. Bay level units, bay mimic, relay and protection panels, RTCC panels, PLCC panels, panels for telecommunication system etc. are to be placed in a separate room in the GIS building. The size of the room shall be such that all the panels for the bays under present scope shall be accommodated. The panel room shall be air-conditioned. Further, the temperature of the room shall be monitored through substation automation system by providing necessary temperature transducers. Ventilation system of suitable capacity shall be provided for each GIS hall.

One EOT Crane of suitable capacity for erection and Maintenance of largest GIS component/assembly and all plant installed in the GIS switchgear room shall be provided in each GIS hall. The crane shall be capable of fulfilling all special requirements for erection

and maintenance of GIS equipment. The capacity of the crane shall be sized to lift the heaviest GIS switchgear component.

For extension of existing GIS, existing facilities shall be suitably augmented/ extended for GIS equipment under present scope.

B.3.6 Control Concept

All the EHV circuit breakers in substation/switching stations shall be controlled and synchronized from the switchyard control room/remote control center. All the isolators shall have control from remote/local whereas the earth switches shall have local control only.

B.4 General Facilities

- a. Line Gantry/Towers are envisaged for bays under present scope only. However, for adjacent future line bay, tower shall be designed for extension (considering Quad conductors for 765 kV and 400 kV future lines) wherever applicable.
- b. Bay extension works at existing substation shall be executed by TSP in accordance with the requirement/provisions mentioned above. However, interface points shall be considered keeping in view the existing design/arrangement at the substation.
- c. TSP has to arrange for construction power and water on its own.
- d. All outdoor steel structures including anchor/foundation bolts shall be fully galvanized. The weight of the zinc coating shall be at least 610 g/m². However, for coastal/creek regions it shall be at least 900 g/m².
- e. In 765 kV and 400 kV switchyard, if spare bay of half diameter is identified as future, all the equipment for Tie and Future Bay shall be designed considering the current rating of line bay i.e. 3150A.
- f. Boundary wall shall be brick masonry wall with RCC frame or Stone masonry wall or Precast RCC wall under present scope along the property line of complete substation area including future switchyard area to prevent encroachment and unauthorized access. Minimum height of the boundary wall shall be of 1.8 m from finished ground level (FGL).
- g. All electrical equipment shall be installed above the Highest Flood Level (HFL) and where such equipment is not possible to be installed above the Highest Flood Level, it shall be ensured that there is no seepage or leakage or logging of water.

B.5 EXTENSION OF EXISTING SUBSTATION

The following drawings/details of existing substation is attached with the RFP documents for further engineering by the bidder.

Sl. No.	Drawing Title	Drawing No./Details	Rev. No.
A.	400 kV South Olpad GIS S/s		
1.0	Single Line Diagram	The substation is under bidding in separate scheme. Thus, drawings are not available at this stage.	
2.0	General Arrangement		
3.0	Earthmat Layout		
4.0	Visual Monitoring System		
5.0	Bus Bar Protection		
6.0	Substation Automation System (SAS)		
B.	400 kV KPS3 GIS S/s-Section I		
1.0	Single Line Diagram	023012-E-IS-SY-1L-0001	H
2.0	General Arrangement	023012-E-IS-SY-EL-0002	C
3.0	Earthmat Layout	Drawings are yet to be finalized by developer.	
4.0	Visual Monitoring System		
5.0	Bus Bar Protection		
6.0	Substation Automation System (SAS)		
C.	400 kV KPS3 GIS S/s-Section II		
1.0	Single Line Diagram	The substation is under bidding in separate scheme. Thus, drawings are not available at this stage.	
2.0	General Arrangement		
3.0	Earthmat Layout		
4.0	Visual Monitoring System		
5.0	Bus Bar Protection		
6.0	Substation Automation System (SAS)		

Bidder is also advised to visit the substation sites and acquaint themselves with the topography, infrastructure such as requirement of roads, cable trench, drainage etc. and also the design philosophy.

SPECIFIC TECHNICAL REQUIREMENTS FOR COMMUNICATION

The communication requirement shall be in accordance to CEA (Technical Standards for Communication System in Power System Operations) Regulations, 2020, CEA (Technical Standards for Construction of Electrical Plants and Electric Lines) Regulations, 2022, CERC (Communication System for inter-State transmission of electricity) Regulations, 2017, and CEA (Cyber Security in Power Sector) Guidelines, 2021, all above documents as amended from time to time.

The complete ISTS communication system commissioned by TSP under the RFP shall be the asset of ISTS and shall be available for usage of ISTS requirements as suggested by CTU from time to time.

The communication services viz. SCADA, VoIP, PMU, AGC and AMR (wherever applicable) have been identified as critical services and therefore shall be provisioned with 2+2 redundancy i.e. 2 channels for Main Control Centre and 2 channels for Backup Control Centre. In order to meet this requirement, suitable redundancy at port and card level need to be ensured by the TSP to avoid any single point of failure which may lead to interruption in real-time grid operation.

PMU to PDC communication (wherever required) shall be through 2 channels to the PDC (main) as there is no backup PDC at present.

Accordingly, all the hardware for communication services of station as stated above shall support dual redundancy for data transmission of station to respective main and backup RLDCs.

In order to meet the requirement for grid management and operation of substations, Transmission Service Provider (TSP) shall provide the following:

For smooth operation of the HVDC system, communication network with high reliability and availability shall be provided for transmission of control and protection signals between the two or more (in case of multi-terminal DC) HVDC terminals. The communication system design shall be as follows:

- Main-I
- Main-II (as hot standby to Main-I)
- Back-up communication

The TSP shall supply, install and commission SDH equipment required for the converter stations at **KPS3 and South Olpad** and the necessary repeater stations. The repeater stations for fibre optic communication are also included in the scope of the TSP. The number and locations of repeaters shall be finalized after survey by TSP.

COMMUNICATION SYSTEMS GENERAL

Duplicated (2X100%) main communication systems (Main-I and Main-II) at KPS3 and South Olpad terminal and its repeaters shall comprise first cubicle of Main Fibre Optic Terminal equipment (FOTE) and second cubicle of Standby FOTE and be provided to meet the requirements of the control, protection, data transfer and telephone systems. System shall be based on the fibre optic communication between the converter stations through \pm 500 KV DC lines. Each Main and Standby FOTE system shall be independent of each other. TSP to design the optical fibre Communication system between the converter stations in such a way that communication is available even when there is complete failure of one FOTE system. All repeater stations required for the communication system shall be provided by TSP. The TSP shall provide all required equipment, accessories, routers, modems and facilities etc., as required, for successful commissioning and use of the communication channels at KPS3 and South Olpad HVDC Bipole terminal.

The backup communication link shall also be provided through OPGW on AC Lines. Necessary support shall be provided by the TSP to other TSP/s whose existing communication network is required to be configured for backup communication. Configuration work shall be done by the backup communication system owner/s for the KPS3 and South Olpad HVDC link in coordination with the TSP. TSP shall be responsible for all interface requirements with the Communication system of the other TSP(s) whose OPGW/Communication equipment are required for successful commissioning of the backup communication link including hardware/accessories etc

C.1.0 Establishment of 2500 MW, \pm 500 kV KPS3 (HVDC) [VSC] terminal station (2x1250 MW) at a suitable location near KPS3 substation with associated interconnections with 400 kV HVAC Switchyard.

- (i) TSP shall supply, install and commission one or more no. FODP (120 F or higher) alongwith panel and approach Cable (24F each) with all associated hardware fittings from gantry tower to Control Room for all the incoming lines envisaged under the present scope.
- (ii) TSP shall supply, install and commission 2 Nos. STM-16 (FOTE) equipment locally patched (in redundant mode connected with separate fibre pairs of same OPGW) alongwith panel/s supporting minimum Five (5) directions with MSP (Multiplex Section Protection – 1+1, excluding local patching) at KPS3 (HVDC) S/s with necessary interfaces to meet the voice and data communication requirement among KPS3 HVDC, KPS3 GIS, South Olpad (HVDC)/ Repeater Stations. The

Transmission Service Agreement

suitable DC Power Supply and backup to be provided for each communication equipment operational in redundant mode.

- (iii) FODP and FOTE equipment with panels shall be provided in Control Room of KPS3 (HVDC) S/s. FOTE and FODP Eq can be accommodated in same panel to optimize space.
- (iv) The FOTE under present scope at HVDC shall be integrated by TSP with the existing FOTE at control room of **KPS3 GIS**. TSP to provide necessary FODP sub rack / Splice trays/ Patch cords etc. and optical interfaces/equipment in the existing FOTE/FODP panels in control room for providing required optical directions with the existing FOTE for onwards data transmission.
- (v) The new communication equipment under the present scope shall be compatible for integration with existing regional level centralized NMS. The local configuration of the new communication equipment shall be the responsibility of TSP. The configuration work in the existing centralized NMS for integration of new Communication equipment shall be done by Regional ULDC Team, however all the necessary support in this regard shall be ensured by TSP.
- (vi) TSP shall supply, install and commission Firewall in redundant mode (1+1) in line with the specification attached at **Annexure F.1**.
- (vii) The maintenance of all the communication equipment and software thereof including FOTE, FODP, approach cable, Repeater Station, PMU, DCPS along with Battery Bank and Firewall shall be the responsibility of TSP.

C.2.0 Establishment of 2500 MW, \pm 500 kV South Olpad (HVDC) [VSC] terminal station (2x1250 MW) along with associated interconnections with 400 kV HVAC Switchyard of South Olpad S/s.

- (i) TSP shall supply, install and commission one or more No. FODP (96 F) or higher) alongwith panel and approach Cable (24F each) with all associated hardware fittings from gantry tower to Control Room for all the incoming lines envisaged under the present scope.
- (ii) TSP shall supply, install and commission 2 Nos. of STM-16 (FOTE) equipment locally patched (in redundant mode connected with separate fibre pairs of same

Transmission Service Agreement

OPGW) alongwith panel/s supporting minimum four(4) directions with MSP (Multiplex Section Protection – 1+1, excluding local patching) at South Olpad (HVDC) S/s with necessary interfaces to meet the voice and data communication requirement among South Olpad (HVDC), South Olpad GIS, KPS3 (HVDC) and Repeater Stations. The suitable DC Power Supply and backup to be provided for each communication equipment operational in redundant mode.

- (iii) FODP and FOTE equipment with panels shall be provided in Control Room of South Olpad (HVDC) S/s. FOTE and FODP Eq can be accommodated in same panel to optimize space.
- (iv) The FOTE under present scope at HVDC shall be integrated by TSP with the existing FOTE at control room of **South Olpad GIS**. TSP to provide necessary approach cables/FODP sub rack / Splice trays/ Patch cords etc. and optical interfaces/equipment in the existing FOTE/FODP panels in control room for providing required optical directions with the existing FOTE for onwards data transmission.
- (v) The new communication equipment under the present scope shall be compatible for integration with existing regional level centralized NMS. The local configuration of the new communication equipment shall be the responsibility of TSP. The configuration work in the existing centralized NMS for integration of new Communication equipment shall be done by Regional ULDC Team, however all the necessary support in this regard shall be ensured by TSP.
- (vi) TSP shall supply, install and commission Firewall in redundant mode (1+1) in line with the specification attached at **Annexure F.1**.
- (vii) The maintenance of all the communication equipment and software thereof including FOTE, FODP, approach cable, Repeater Station, PMU, DCPS along with Battery Bank and Firewall shall be the responsibility of TSP.

C.3.0 KPS3 – KPS3 (HVDC) 400 kV 2xD/C (Quad ACSR/AAAC/AL59 moose equivalent) line.

On KPS3 – KPS3 (HVDC) 400 kV 2xD/C line, TSP shall supply, install and commission One (1) No. OPGW cable containing 24 Fibres (24F) on one E/W peak and conventional earth wire on other E/W peak **on each of the D/C lines**.

The TSP shall install this OPGW from gantry of KPS3 GIS up to the gantry of KPS3 (HVDC) S/s with all associated hardware including Vibration Dampers, mid-way and gantry Joint Boxes (called **OPGW Hardware** hereafter) and finally terminate in Joint Boxes at end Substations. The transmission line length is 2 kms (approx.) where repeater is not required to meet link budget requirement of KPS3 GIS – KPS3 (HVDC).

C.4.0 4 No. of 400 kV line bays at KPS3 for KPS3 – KPS3 (HVDC) 400 kV 2xD/C line

- (i) TSP shall supply, install and commission one or more No. FODP (144 F or higher) along with panel and required Approach Cable (24F) with all associated hardware fittings from gantry tower to Bay Kiosk and from the Bay Kiosk to Control room.
- (ii) TSP shall supply, install and commission 2 Nos. of STM-16 (FOTE) equipment along with panel/s supporting minimum three (3) directions with MSP (Multiplex Section Protection – 1+1, excluding local patching) at KPS3 GIS with necessary interfaces to meet the voice and data communication requirement between, KPS3 (HVDC) and KPS3 GIS. The suitable DC Power Supply and backup to be provided for each communication equipment operational in redundant mode.
- (iii) FOTE/FODP panel shall be installed in the new Bay Kiosk/ Switchyard Panel Room (SPR). The FOTEs under present scope shall be integrated by TSP with the existing/proposed FOTE at control room of **KPS3 GIS**. TSP to provide necessary FODP sub rack / Splice trays/ Patch cords etc. and optical interfaces/equipment in the existing FOTE/FODP panels in control room for providing required optical directions with the existing FOTE for onwards data transmission.

In case spare optical direction is not available in the existing FOTE at the control room, the TSP shall coordinate with station owner to reconfigure the directions in existing FOTE at control room. Alternatively, the TSP may integrate the FOTE under the present scope with existing FOTE in the nearby Kiosk connected to the control room FOTE (if available with spare direction). For this purpose, TSP shall provide necessary FODP sub rack / Splice trays/ Patch cords etc. and suitable optical interfaces/ equipment in the existing FOTE/FODP panels in another Kiosk (SPR).

- (iv) FOTE and FODP can be accommodated in same panel to optimize space.

- (v) The new communication equipment under the present scope shall be compatible for integration with existing regional level centralized NMS. The local configuration of the new communication equipment shall be the responsibility of TSP. The configuration work in the existing centralized NMS for integration of new Communication equipment shall be done by Regional ULDC Team, however all the necessary support in this regard shall be ensured by TSP.

C.5.0 ±500 kV HVDC Bipole line between KPS3 (HVDC) and South Olpad (HVDC) (with Dedicated Metallic Return) (capable to evacuate 2500 MW).

On ±500 kV HVDC Bipole line between KPS3 (HVDC) and South Olpad (HVDC) (with Dedicated Metallic Return), TSP shall supply, install and commission One (1) no. OPGW cable containing 24 Fibres (24F) on one E/W peak and conventional earth wire on other E/W peak. OPGW diameter shall be in line with earthwire parameters mentioned in Annexure-E1 (Specific technical requirements for HVDC transmission line).

The TSP shall install this OPGW from gantry of KPS3 (HVDC) up to the gantry of South Olpad (HVDC) S/s with all associated hardware including Vibration Dampers, mid-way and gantry Joint Boxes (called **OPGW Hardware** hereafter) and finally terminate in Joint Boxes at end Substations. The transmission line length is 600 km (approx.) where repeaters are required to meet link budget requirement of KPS3 (HVDC) – South Olpad (HVDC).

TSP shall finalize the location and number of repeater stations depending upon the actual site conditions. Further TSP shall comply to the requirements mentioned as per **Appendix-F.1**.

Maintenance of OPGW Cable, OPGW Hardware and repeater equipment and items associated with repeater shelter shall be responsibility of TSP.

Specific Requirement for Phasor Measurement Units (PMUs)

TSP shall supply, install and commission required No. of Phasor Measurement Units (PMUs) at all the locations under the scope of TSP under this RFP as per CEA (Technical Standards for Construction of Electrical Plants and Electric Lines) Regulations, 2022 (along with all amendments if any), and all the applicable Regulations, Standards, Guidelines issued time to time. These PMUs shall be provided with GPS clock and LAN switch and shall connect with LAN switch of control room of respective substations/ generating stations with Fibre Optic cable. These PMUs shall be connected with the FOTE at Substation/ generating stations for onwards data transmission to the PDC (Phasor Data Concentrator) located at respective RLDC. Configuration work in existing PDC at RLDC for new PMU integration shall be done by respective RLDC, however all the necessary support in this regard shall be ensured by TSP. The maintenance of all the PMUs and associated equipment shall be the responsibility of TSP.

Note: Existing Station owner/s to provide necessary support to integrate different equipment and applications of new extended bays with the existing substation e.g. Communication (through FOTE), Voice etc. for smooth operation and monitoring of new added grid elements.

Repeater Requirements

FOTE to be provided by TSP in repeater station/s shall be 2x STM-16 (FOTE) equipment (in redundant mode connected with separate fibre pairs of same OPGW/UGFO/Approach Cable)

- If the repeater location is finalized in the Control Room of a nearby substation, TSP shall provide 1 no. OPGW (48F) on a single Earthwire peak with OPGW Hardware and mid-way Joint Boxes etc. of the line crossing the main line and 1 no. Approach Cable (48F) with all associated hardware fittings, to establish connectivity between crossing point of main transmission line up to the repeater equipment in substation control room.

TSP shall co-ordinate for Space and DC power supply sharing for each operational communication equipment at repeater station in redundant mode.

TSP shall provide FODP, FOTE (with STM-16 capacity) with suitable interfaces require for link budget of respective link.

OR

- If the repeater location is finalized in the nearby substation premises, the TSP shall identify the Space for repeater shelter in consultation with station owner. Further TSP shall provide 1 no. OPGW (48F) on a single Earthwire peak with OPGW Hardware and mid-way Joint Boxes etc. of the line crossing the main line and 1 no. Approach Cable (48F) / UGFO (48F) with all associated hardware fittings, to establish connectivity between crossing point of main transmission line up to the substation where the repeater shelter is to be housed.

TSP shall provide repeater shelter along with FODP, FOTE (with STM-16 capacity) with suitable interfaces require for link budget of respective link, reliable power supply provisioning for AC and DC supply, battery bank, Air Conditioner and other associated systems for each operational communication equipment at repeater station in redundant mode.

OR

- If the repeater location is finalized on land near the transmission tower. TSP shall make the provisions for Land at nearby tower for repeater shelter. Further TSP shall

Transmission Service Agreement

provide 1 no. Approach Cable (48F) / UGFO (48F) with all associated hardware fittings to establish connectivity up to the location of repeater shelter.

TSP shall provide repeater shelter along with FODP, FOTE (with STM-16 capacity) with suitable interfaces require for link budget of respective link, reliable power supply provisioning for AC and DC supply, battery bank, Air Conditioner and other associated systems for each operational communication equipment at repeater station in redundant mode.

Maintenance of OPGW Cable and **OPGW Hardware**, repeater equipment and items associated with repeater shelter shall be responsibility of TSP.

Transmission Service Agreement

Proposed Communication for Transmission System for Evacuation of Power from potential renewable energy zone in Khavda area of Gujarat under Phase-V (8 GW): Part C

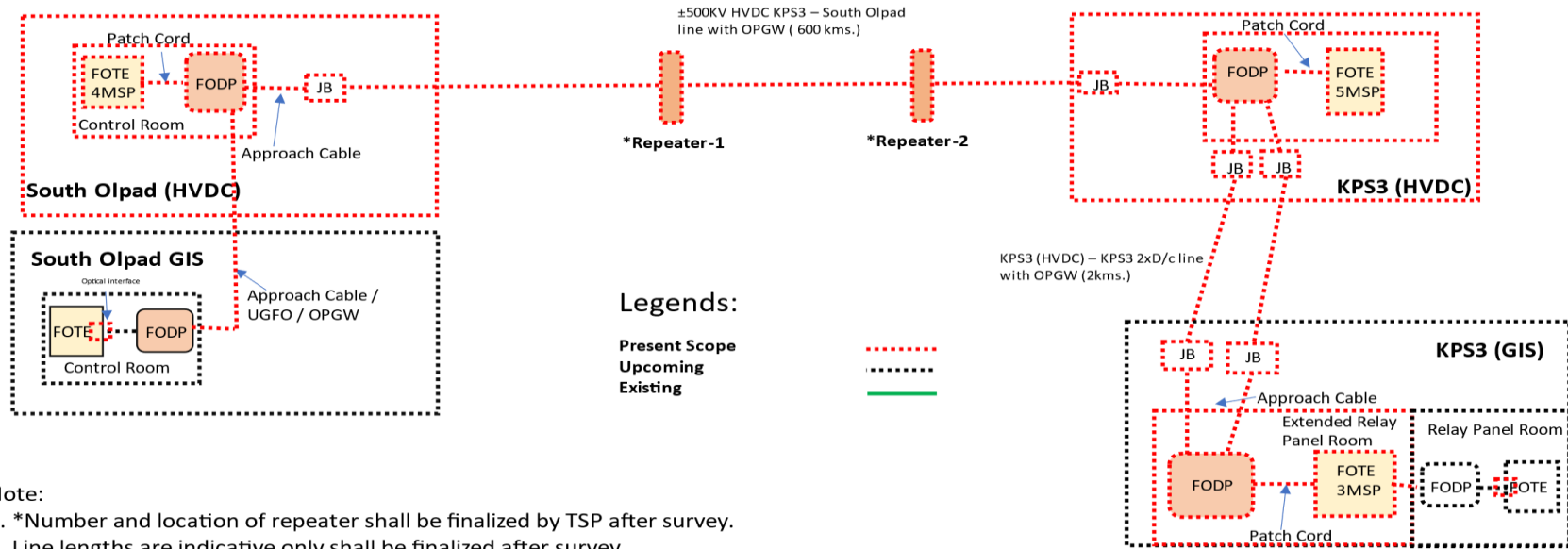

Note:

1. *Number and location of repeater shall be finalized by TSP after survey.
2. Line lengths are indicative only shall be finalized after survey.
3. Two no. of FOTE are to be provided at KPS3 HVDC, KPS3 GIS SPR & South Olpad HVDC Stations.
4. The existing FOTE at KPS3 GIS SPR and South Olpad GIS shall be integrated with respective FOTE to be provided at HVDC stations.

Figure F.1

Next Generation Firewall (NGFW)

TSP shall provide 2 NGFW one in Main and another in Standby mode having electrical ethernet interfaces/ports and placed between FOTE and SAS gateway/s at the substation. All ethernet based applications shall be terminated in the firewall ports directly (e.g. PMU, AMR, VOIP, SAS/SCADA etc.). Each port of firewall shall work as a separate zone. Firewall shall be hardware based with features of Block/Allow/drop and IPsec VPN (network encryption).

The number of ports/interfaces in each firewall (i.e. Main and Standby) shall be minimum 16 Nos. TSP shall provide either single firewall or multiple firewalls to meet this interfaces requirement, each for main as well as standby firewall. Minimum throughput of firewall shall be 300 Mbps.

The Firewall shall be managed/ configured as standalone at present and shall also have compatibility to manage/configure through Centralized Management Console (CMC) remotely in future.

Firewall shall be tested and certified for ISO15408 Common Criteria for least EAL4+. Further, the OEM must certify that it conforms to Secure Product Development Life Cycle requirements as per IEC62443-4-1. The firewall shall generate reports for NERC-CIP Compliance.

The specifications for the firewalls are given at **Annexure-F.2** and schematic diagram showing firewall placement given at **Figure F.2**.

Specifications of Next Generation Firewall (NGFW)

1. NGFW shall have following features including but not limited to:
Encryption through IPSec VPN (Virtual Private Network), Deep Packet Inspection (DPI), Denial of service (DoS) and Distributed Denial of Service (DDoS) prevention, Port Block/ Allow, rules/ policies for block/allow, IP (Internet Protocol) and Media Access Control (MAC) spoofing protection, threat detection, Intrusion Prevention System (IPS), Anti-Virus, Anti-Spyware, Man In The Middle (MITM) attack prevention.
2. The proposed firewall shall be able to handle (alert, block or allow) unknown /unidentified applications e.g. unknown TCP and UDP packets. It shall have the provision to define application control list based on application group and/or list.
3. Firewall shall have feature and also have capability to update the definition/ Signatures of Anti-Virus online as well as offline. Firewall shall also be compatible to update the definitions/signatures through CMC. There shall be a defined process for security patching and firmware up-gradation. There shall be a feature to field validate firmware checksum. The same shall also be validated before using the OEM provided file/binary in the process of firmware up-gradation and security patching
4. Firewall shall have Management Console port to configure remotely.
5. Firewall shall be EMI/EMC compliant in Substation environment as per IEC 61850-3.
6. Firewall shall be rack mounted in existing standard equipment cabinets.
7. Firewall shall have support of SCADA applications (IEC-60870-5-104), IEC, PMU (IEEE C37.118), Sub-Station Automation System (IEC 61850), Ethernet and other substation environment protocols.
8. Client based Encryption/ VPN must support different Operating System platforms e.g. Windows, Linux and Mac.
9. The solution must have content and comprehensive file detection policies, blocking the files as function of their types, protocols and directions.
10. Firewall shall have logging facility as per standard logs/events format. Firewall shall have features to export the generated/stored logs/events in csv (Comma Separated Value) and also any other standard formats for offline usage, analysis and compliance. Firewall shall have suitable memory architecture and solution to store and be able to export all logs/events for a period of last 90 days at any given time.
11. Firewall shall have features and be compatible with local as well as central authentication system (RADIUS, LDAP, or TACACS+) for user account and access right management. It shall also have Role Based User management feature.
12. Firewall shall have the capability to configure sufficient number of VLANs.
13. Firewall shall have the capability to support sufficient number of sessions.
14. Firewall shall have provision to configure multiple IP Sec VPNs, at least 100 Nos. (one-to-many or many-to-one). Shall support redundant operation with a similar router after creation of all the IP Sec VPN. IPSec VPN shall support encryption protocols as

Transmission Service Agreement

AES128, AES256 and hashing algorithms as MD5 and SHA1. IPsec VPN throughput shall support at least 300 Mbps

15. Firewall shall be capable of SNMP v3 for monitoring from Network Management system. It shall also have SNMPv3 encrypted authentication and access security
16. Firewall shall support in Active/Passive or Active-Active mode with High Availability features like load balancing, failover for firewall and IPsec VPN without losing the session connectivity.
17. Firewall should have integrated traffic shaping (bandwidth, allocation, prioritisation, etc.) functionality
18. Shall support simultaneous operation with both IPv4 and IPv6 traffic
19. Firewall shall be compatible with SNTP/NTP or any other standards for clock synchronization
20. Firewall shall have the features of port as well as MAC based security
21. Firewall shall support exporting of logs to a centralized log management system (e.g. syslog) for security event and information management.
22. Firewall time shall be kept synchronised to official Indian Timekeeping agency, time.nplindia.org.
23. Firewall product shall be provided with all applicable updates at least until 36 months since the applicable date of product shipping to the concerned utility.

Transmission Service Agreement

Firewall Placement Diagram

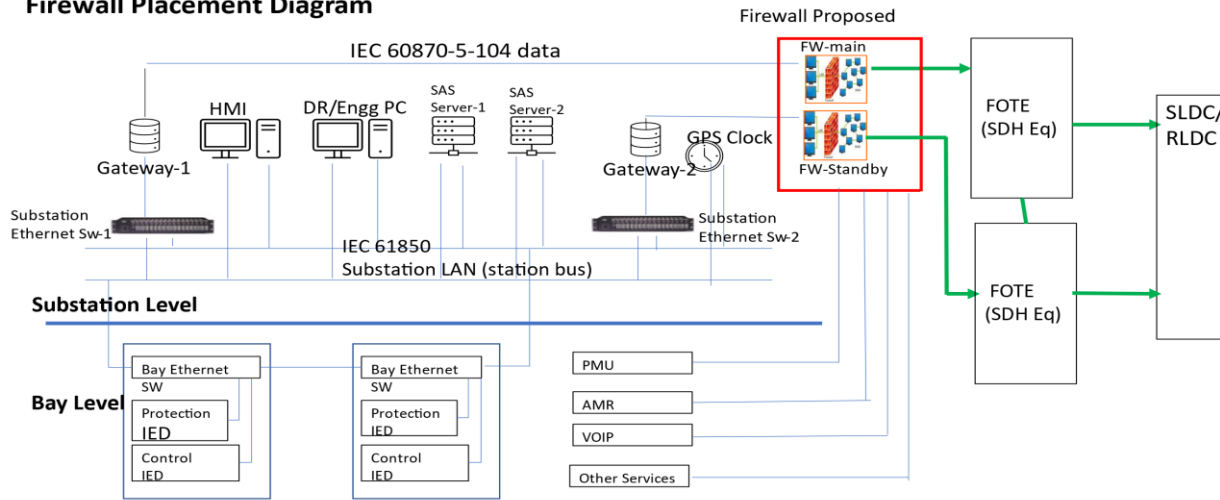

Figure F.2

C.6.0 PLCC and PABX:

Power line carrier communication (PLCC) equipment complete for speech, tele-protection commands and data channels shall be provided on each transmission line. The protections for transmission line and the line compensating equipment shall have hundred percent back up communication channels i.e. two channels for tele-protection in addition to one channel for speech plus data for each direction. The PLCC equipment shall in brief include the following:

- (i) Coupling device, line traps, carrier terminals, protection couplers, HF cables, PABX (if applicable) and maintenance and testing instruments.
- (ii) At new substation, a telephone exchange (PABX) of 24 lines shall be provided at as means of effective communication among various buildings of the substation, remote end substations and with control centers (RLDC/SLDC) etc.
- (iii) Coupling devices shall be suitable for phase to phase coupling for 400 kV Transmission lines. The pass band of coupling devices shall have sufficient margin for adding communication channel in future if required. Necessary protection devices for safety of personnel and low voltage part against power frequency voltages and transient over voltage shall also be provided.
- (iv) The line traps shall be broad band tuned suitable for blocking the complete range of carrier frequencies. Line Trap shall have necessary protective devices such as lightning arresters for the protection of tuning device. Decoupling network consisting of line traps and coupling capacitors may also be required at certain substation in case of extreme frequency congestion.
- (v) The carrier terminals shall be of single side-band (SSB) amplitude modulation (AM) type and shall have 4 kHz band width. PLCC Carrier terminals and Protection couplers shall be considered for both ends of the line.
- (vi) PLCC equipment for all the transmission lines covered under the scheme shall be provided by TSP as per following configuration. CVT and Wave trap for all the line bays under present scope shall be provided by TSP.

Transmission Service Agreement

Sl. No	Line name	PLCC configuration
1.	KPS3 – KPS3 (HVDC) 400 kV 2xD/C line	1 set Analog PLCC + 1 set Digital Protection Coupler for each circuit at both ends. OR 2 Sets of Digital Protection Coupler for each circuit at both ends with physically diverted path.

Further, CVT and Wave trap for all line bays under present scope shall be provided by TSP where analog PLCC is required.

- (vii) All other associated equipment like cabling, coupling device and HF cable shall also be provided by the TSP.
- (viii) 2 sets of 48 V battery banks for PLCC and communication equipment shall be provided at each new Substation with at least 10 hours battery backup and extended backup, if required.

Frequently Asked Queries:

1.0 Transmission Line:

1.1 Please clarify that whether shutdowns for crossing of existing transmission lines of POWERGRID/STUs/ Power Evacuation Lines from Generation Plants/ Any other Transmission Licensee will be given to TSP on chargeable basis or free of cost.

Reply: Shutdowns for crossing of existing transmission lines of POWERGRID/ STUs/ Power Evacuation Lines from Generation Plants/ Any other Transmission Licensee will be given to TSP by the concerned owner of the lines as per their own terms and conditions. As far as shutdown of ISTS lines are concerned the same can be availed by approaching respective Regional Power Committee.

1.2 We understand that the suggested swing angle criteria are applicable for Suspension Insulator in Suspension Tower. Further, you are requested to provide similar swing angle and clearance criteria for Pilot Insulator with Jumper and Jumper.

Reply: It is clarified that the swing angle criteria (as mentioned in RFP) for transmission lines is applicable for Suspension Insulator in Suspension Tower. Further, as per Clause 3.0 of Specific Technical Requirements for transmission lines, Transmission service Provider (TSP) shall adopt any additional loading/design criteria for ensuring reliability of the line, if so desired and /or deemed necessary.

1.3 We request you to kindly allow that use of diamond configuration at Power line crossings and the existing owner of the lines may be directed to allow the same for the successful bidders.

Reply: Power line crossing including Diamond configuration is responsibility of the TSP. TSP shall formally submit the profile of the crossing section to the owner of the existing line suggesting proposed crossing alternatives. The crossing will have to be carried out as per approval of owner of the existing line.

1.4 It is requested you to kindly provide present status of Forest Clearances if any transmission line corridor area falling in wildlife forest / reserve forest/ mangroves.

Reply: Based on the preliminary route survey, the process of initiation of forest

clearance for the forest stretches, if any, enroute the proposed line alignment will be initiated by way of writing letters to the concerned authority(ies). However, it may be noted that it will be the responsibility of TSP for obtaining forest clearance for the forest stretches as provided in the survey report and also for any forest area encountered during detailed survey.

2.0 Substation

2.1 We understand that space for storage of O&M spare shall be provided by existing owner within the station boundary without any cost. Kindly confirm.

Reply: Space for storage of O&M spares shall be arranged by TSP on its own.

2.2 We presume that the O&M for the end Termination bays will be in the scope of the TSP and TSP shall not be liable for any payment towards O&M to the existing owner of the substation. Kindly confirm.

Reply: Operation and maintenance of the bays is solely responsibility of the TSP. TSP shall follow CEA,s “ Operation and Maintenance (O&M) guidelines and Standard Format for Memorandum of Understating between New TSP and Existing TSP” issued by CEA vide its letter No. I/28514/2023 dated 22.06.2023. Copy of the guideline is available on CEA website at following link:

https://cea.nic.in/wp-content/uploads/pse_td/2023/06/om_guidelines.pdf

2.3 With reference to subject scheme of existing sub-station, we assumed following scope of work:

- (a) We assumed internal road is available and need not to consider in the present scope of work.
- (b) Drainage is available and need not to consider in the present scope of work.
- (c) Cable trench extension in adjacent to Main cable trench only under present scope of work.
- (d) Levelled area being provided by developer for bay extension.

Reply: Regarding requirement of internal road, drainage, cable trench, leveling of the bay extension area, bidder is advised to visit site and acquaint themselves with the provisions/facilities available at substation.

2.4 Kindly provide the soil investigation report of soil parameters of existing substation.

..... [Insert Name of the SPV]

215

| _____ 2024

Reply: Bidder is advised to visit the substation site and ascertain the requisite parameters.

2.5 Kindly confirm, energy accounting of aux. power consumption. Whether it will be on chargeable basis or part of transmission loss.

Reply: It will be on chargeable basis.

2.6 We understand that VMS requirement is for unmanned stations only. For Manned stations VMS is not compulsory.

Reply: VMS shall be provided in line with requirements of RfP document.

2.7 It is understood that Construction water and power shall be provided free of cost to TSP by respective substation owner for construction of new bays.

Reply: Arrangement of construction power and water is in the scope of TSP.

2.8 It is understood that existing fire hydrant system shall be extended by the TSP for bay extension.

Reply: Existing fire hydrant system shall be extended from existing system (if required)

2.9 Please clarify that Status of land acquisition for Substations. Whether the lands have been acquired by BPC and will be transferred to TSP.

Reply: The acquisition of land for substation is in the scope of TSP.

2.10 We understood that no any dedicated metering CT and CVT required for Line/feeders. Further, we understood that requisite Energy meters for various 765 kV, 400 kV and 220 kV Feeders shall be provided and installed by CTU free of cost to TSP.

Reply: Dedicated metering CT and CVT are not required for line/feeders. Metering core of existing CT/CVT can be used provided accuracy class is matching with metering requirement. Requisite Special Energy Meters shall be provided and installed by CTU at the cost of TSP in C&P panel subject to space availability, else, in separate metering panel (to be provided by TSP at its cost).

3.0 Communication

3.1 What are the usage of OPGW, FOTE, PMU etc. under communication requirement of RFP?

Reply: User shall be responsible for providing compatible equipment along with appropriate interface for uninterrupted communication with the concerned control center and shall be responsible for successful integration with the

..... [Insert Name of the SPV]

communication system provided by CTU.

Communication systems e.g. OPGW, FOTE, PMU etc. are required for grid operation through RLDC/SLDC, speech communication, tele-protection and tele-metering.

3.2 Is space for installation of communication panels are provided to TSP in existing Substations incase new bays are in the scope of TSP?

Reply: The space related issues are deliberated in the RFP itself. TSP to carry out survey of the existing substation for physical space requirement. In case space is not available in the existing substation then TSP shall accommodate the same in the respective bay SPR (Switchyard Panel Room)/Bay Kiosk/ Relay panel room in case of GIS s/s. Further, TSP to connect and integrate the proposed FOTE with the existing FOTE in the control room.

In Case 132 kV Substation TSP shall accommodate the said panels either by extension of existing control room or other arrangements.

3.3 How is the OPGW laying done in case of LILO lines?

Reply: In case LILO lines are on same towers (e.g. both Line in and Line Out portion are on same towers, generally done LILO of S/C lines). Then 2x24F OPGW shall be required to install by TSP on both earthwire peak on 400 kV and 765 kV lines where two E/W peaks are available. On 220 kV and 132 kV lines where only one E/W peak is available TSP to install one no. 48F OPGW.

Incase LILO lines are on different towers (e.g. both Line In and Line Out portion are on different towers, generally done LILO of D/C lines). Then 1x24F OPGW shall be required to install by TSP on one earthwire peak, on both Line in and Line Out portions of 400 kV and 765 kV lines. On 220 kV and 132 kV lines where only one E/W peak is available TSP to install one no. 24F OPGW in place of conventional earthwire.

3.4 How is the OPGW laying done in case Multi circuit Towers?

Reply: In case two different lines are using common multi circuit portion for some distance (originating from different stations, may be terminating on same or on different stations). Two No. 24F OPGW to be installed on both E/W peaks for common M/C portion of 765 kV and 400 kV lines.

Incase 220/132 kV lines using multi circuit portion where single E/W peak is available one no. 48F may be installed for common multi circuit portion.

Schedule: 2

Scheduled COD

[Note: As referred to in the definition of “Element”, “Scheduled COD”, and in Articles 3.1.3 (c), 4.1 (b) and 4.3 (a) of this Agreement]

Sl. No.	Name of the Transmission Element	Scheduled COD	Percentage of Quoted Transmission Charges recoverable on Scheduled COD of the Element of the Project	Element(s) which are pre-required for declaring the commercial operation (COD) of the respective Element
1.	Establishment of 2500 MW, ± 500 kV KPS3 (HVDC) [VSC] terminal station (2x1250 MW) at a suitable location near KPS3 substation with associated interconnections with 400 kV HVAC Switchyard*	48 months from SPV transfer	100%	All Elements are required to be commissioned simultaneously as their utilization is dependent on commissioning of each other.
2.	Establishment of 2500 MW, ± 500 kV South Olpad (HVDC) [VSC] terminal			

..... [Insert Name of the SPV]

Transmission Service Agreement

Sl. No.	Name of the Transmission Element	Scheduled COD	Percentage of Quoted Transmission Charges recoverable on Scheduled COD of the Element of the Project	Element(s) which are pre-required for declaring the commercial operation (COD) of the respective Element
	station (2x1250 MW) along with associated interconnections with 400 kV HVAC Switchyard of South Olpad S/s*			
3.	<p>Establishment of KPS3 (HVDC) S/s along with 2x125 MVAR, 420 kV bus reactors along with associated interconnections with HVDC Switchyard*. The 400 kV bus shall be established in 2 sections through 1 set of 400 kV bus sectionaliser to be kept normally OPEN.</p> <p>400/33 kV, 2x50 MVA transformers for exclusively supplying auxiliary power to HVDC terminal.</p>			
4.	KPS3 – KPS3 (HVDC) 400 kV 2xD/C (Quad ACSR/AAAC/AL59 moose equivalent) line along with the line bays at both substations			
5.	±500 kV HVDC Bipole line between KPS3 (HVDC) and South Olpad (HVDC) (with Dedicated Metallic Return) (capable to evacuate 2500 MW)			

Schedule: 3

Safety Rules and Procedures

[Note: As referred to in Articles 5.6 of this Agreement]

1: Site Regulations and Safety:

The TSP shall establish Site regulations within sixty (60) days from fulfilment of conditions subsequent, as per Prudent Utility Practices setting out the rules to be observed till expiry of the Agreement at the Site and shall comply therewith.

Such Site regulations shall include, but shall not be limited to, rules in respect of security, safety of the Project, gate control, sanitation, medical care, and fire prevention, public health, environment protection, security of public life, etc.

Copies of such Site regulations shall be provided to the Nodal Agency and the CEA for the purpose of monitoring of the Project.

2: Emergency Work:

In cases of any emergency, the TSP shall carry out all necessary remedial work as may be necessary.

If the work done or caused to be done by any entity, other than the TSP, the TSP shall, reimburse the actual costs incurred, to the other Party carrying out such remedial works.

3: Site Clearance:

In the course of execution of the Agreement, the TSP shall keep the Site reasonably free from all unnecessary obstruction, storage, remove any surplus materials, clear away any wreckage, rubbish and temporary works from the Site, and remove any equipment no longer required for execution of the Agreement. After completion of all Elements of the Project, the TSP shall clear away and remove all wreckage, rubbish and debris of any kind from the Site, and shall leave the Site clean and safe.

4: Watching and Lighting:

The TSP shall provide and maintain at its own expense all lighting, fencing, and watching when and where necessary for the proper construction, operation, maintenance / repair of any of the Elements of the Project, or for the safety of the owners and occupiers of adjacent property and for the safety of the public, during such maintenance / repair.

Schedule: 4

Computation of Transmission Charges

1.1 General

The Monthly Transmission Charges to be paid to the TSP for providing Transmission Service for any Contract Year during the term of the Agreement shall be computed in accordance with this Schedule and paid as per Sharing Regulations.

Illustration regarding payment of Transmission Charges under various scenarios (considering definitions of Contract Year, Expiry Date & Monthly Transmission Charges above) is as below: -

Illustration-1: In case the Project Elements achieve COD as per Schedule

Quoted Transmission Charges: **Rs. 140 Million**

Completion Schedule:

Element No.	Completion Schedule in Months	Scheduled CoD of the Element	Actual CoD of the Element	% Charges recoverable on Scheduled CoD of the Element
Element 1	28	1-Feb-2018	1-Feb-2018	25%
Element 2	38	1-Dec-2018	1-Dec-2018	75%

Tariff Payable as follows:

Transmission Service Agreement

Transmission Charges for Element 1			Transmission Charges for Element 2		
1-Feb-18 to 31-Mar-18	140 X 25% X ((28+31)/365)	5.65		--	0.00
1-Apr-18 to 30-Nov-18	140 X 25% X (244/365)	23.39		--	0.00
1-Dec-18 to 31-Mar-19	140 X 100% X (121/365)				46.41
2	140 X 100% X 1				140
3	140 X 100% X 1				140
4	140 X 100% X 1				140
5	140 X 100% X 1				140
.....					
.....					
36 (1-Apr to 30- Nov)	140 X 100% X (244/365)				93.59

Illustration-2: In case of extension of Scheduled COD as per Article 4.4.1 & 4.4.2 of this Agreement

Quoted Transmission Charges: **Rs. 140 Million**

Completion Schedule:

Element No.	Completion Schedule in Months	Scheduled CoD of the Element	Actual CoD of the Element	% Charges recoverable on Scheduled CoD of the Element
Element 1	20	1-Feb-2018	1-Jul-2018	25%
Element 2	28	1-Oct-2018	1-Dec-2018	75%

Tariff Payable as follows:

Transmission Charges for Element 1			Transmission Charges for Element 2		
1-Feb-18 to 31-Mar-18	--	0.00		--	0.00
1-Apr-18 to 30-Jun-18	--	0.00		--	0.00
1-Jul-18 to 30-Nov-18	140 X 25% X (153/365)	14.67		--	0.00

..... [Insert Name of the SPV]

222

| _____ 2024

Transmission Service Agreement

1-Dec-18 to 31-Mar-19	140 X 100% X (121/365)	46.41
2	140 X 100% X 1	140
3	140 X 100% X 1	140
4	140 X 100% X 1	140
5	140 X 100% X 1	140
.....		
.....		
36 (1-Apr to 30- Nov)	140 X 100% X (244/365)	93.59

Transmission Service Agreement

Illustration-3: In case of delay in achieving COD of Project & all individual Elements (COD of the Project achieved in Contract Year 1)

Quoted Transmission Charges: **Rs. 140 Million**

Completion Schedule:

Element No.	Completion Schedule in Months	Scheduled CoD of the Element	Actual CoD of the Element	% Charges recoverable on Scheduled CoD of the Element
Element 1	20	1-Feb-2018	1-Dec-2018	25%
Element 2	28	1-Oct-2018	1-Dec-2018	75%

Tariff Payable as follows:

Transmission Charges for Element 1			Transmission Charges for Element 2		
1-Feb-18 to 31-Mar-18	--	0.00		--	0.00
1-Apr-18 to 30-Sept-18	--	0.00		--	0.00
1-Oct-18 to 30-Nov-18	--	0.00	1-Oct-18 to 30-Nov-18	--	0.00
1-Dec-18 to 31-Mar-19	140 X 100% X (121/365)				46.41
2	140 X 100% X 1				140
3	140 X 100% X 1				140
4	140 X 100% X 1				140
5	140 X 100% X 1				140
.....					
.....					
36 (1-Apr to 30-Nov)	140 X 100% X (244/365)				93.59

Illustration-4: In case of delay in achieving COD of Project & all individual Elements (COD of the Project achieved in Contract Year other than Contact Year 1)

Quoted Transmission Charges: **Rs. 140 Million**

Completion Schedule:

Element No.	Completion Schedule in Months	Scheduled CoD of the Element	Actual CoD of the Element	% Charges recoverable on Scheduled CoD of the Element
Element 1	38	1-Oct-2019	1-May-2020	25%
Element 2	38	1-Oct-2019	1-May-2020	75%

Tariff Payment to be paid as:

Transmission Charges for Element 1			Transmission Charges for Element 2		
1-Oct-19 to 31-Mar-20	--	0.00	1-Oct-19 to 31-Mar-20	--	0.00
1-Apr-20 to 30-Apr-20	-	0.00	1-Apr-20 to 30-Apr-20	-	0.00
1-May-20 to 31-Mar-21	140 X 100% X (335/365)				128.49
2	140 X 100% X 1				140
3	140 X 100% X 1				140
4	140 X 100% X 1				140
5	140 X 100% X 1				140
.....					
.....					
36 (1-Apr to 30-Apr)	140 X 100% X (30/ 365)				11.51

Transmission Service Agreement

Illustration5: In case of delay in achieving COD of Element but Project COD achieved on time

Quoted Transmission Charges: **Rs. 140 Million**

Completion Schedule:

Element No.	Completion Schedule in Months	Scheduled CoD of the Element	Actual CoD of the Element	% Charges recoverable on Scheduled CoD of the Element
Element 1	20	1-Feb-2018	1-Jul-2018	25%
Element 2	30	1-Dec-2018	1-Dec-2018	75%

Tariff Payable as follows:

Transmission Charges for Element 1			Transmission Charges for Element 2		
1-Feb-18 to 31-Mar-18	--	0.00		--	0.00
1-Apr-18 to 30-Jun-18	--	0.00		--	0.00
1-Jul-18 to 30-Nov-18	140 X 25% X (153/365)	14.67		--	0.00
1-Dec-18 to 31-Mar-19	140 X 100% X (121/365)				46.41
2	140 X 100% X 1				140
3	140 X 100% X 1				140
4	140 X 100% X 1				140
5	140 X 100% X 1				140
.....					
.....					
36 (1-Apr to 30-Nov)	140 X 100% X (244/365)				93.59

Illustration-6: In case of early commissioning of Project

Quoted Transmission Charges: **Rs. 140 Million**

Completion Schedule:

Element No.	Completion Schedule in Months	Scheduled CoD of the Element	Actual CoD of the Element	% Charges recoverable on Scheduled CoD of the Element
Element 1	38	1-Oct-2019	1-Jul-2019	25%
Element 2	38	1-Oct-2019	1-Jul-2019	75%

Tariff Payment to be paid as:

Transmission Charges for Element 1		Transmission Charges for Element 2	
1-July-19 to 31-Mar-20	140 X 100% X (274/365)		105.09
2	140 X 100% X 1		140
3	140 X 100% X 1		140
4	140 X 100% X 1		140
5	140 X 100% X 1		140
.....			
.....			
36 (1-Apr to 30-Jun)	140 X 100% X (91/365)		34.91

Illustration-7: In case of early commissioning of an element

Quoted Transmission Charges: **Rs. 140 Million**

Completion Schedule:

Element No.	Completion Schedule in Months	Scheduled CoD of the Element	Actual CoD of the Element	% Charges recoverable on Scheduled CoD of the Element
Element 1	38	1-Oct-2019	1-Apr-2019	25%
Element 2	38	1-Jul-2019	1-Jul-2019	75%

Tariff Payment to be paid as:

Transmission Charges for Element 1			Transmission Charges for Element 2		
1-Apr-2019 to 30-Jun-19	140 X 25% X (91/365)	8.72	1-Apr-2019 to 30-Jun-19	--	0.00
1-July-19 to 31-Mar-20	140 X 100% X (274/ 365)				105.09
2	140 X 100% X 1				140
3	140 X 100% X 1				140
4	140 X 100% X 1				140
5	140 X 100% X 1				140
.....					
.....					
36 (1-Apr-30-Jun)	140 X 100% X (91/365)				34.91

The Transmission Charges shall be payable on monthly basis as computed above.

1.2 Computation of Monthly Transmission Charges

The Monthly Transmission Charges for any month m in a Contract Year n shall be calculated as below:

For AC System:

- a. If Actual Transmission System Availability for the month m of contract year n is greater than or equal to 98% and less than or equal to 98.5%;

$$\text{Monthly Transmission Charges MTC}(m) = T_{mn} * 1$$

- a. If Actual Transmission System Availability for the month m of contract year n exceeds 98.5% and less than or equal to 99.75%;

$$\text{Monthly Transmission Charges MTC}(m) = T_{mn} * (AA/ 98.5\%)$$

..... [Insert Name of the SPV]

Transmission Service Agreement

- c. If Actual Transmission System Availability for the month m of contract year n is greater than 99.75%;

$$\text{Monthly Transmission Charges MTC}(m) = T_{mn} * (99.75\% / 98.5\%)$$

- d. If Actual Transmission System Availability for the month m of contract year n is less than 98% and greater than or equal to 95.00%;

$$\text{Monthly Transmission Charges MTC}(m) = T_{mn} * (AA / 98\%)$$

- e. If Actual Transmission System Availability for the month m of contract year falls below 95%;

$$\text{Monthly Transmission Charges MTC}(m) = T_{mn} * (AA / 98\%) - 0.02 * (T_{mn} * (AA / 95\%))$$

For DC System:

- a. If Actual Transmission System Availability for the month m of contract year n is greater than or equal to 95% and less than or equal to 96%;

$$\text{Monthly Transmission Charges MTC}(m) = T_{mn} * 1$$

- b. If Actual Transmission System Availability for the month m of contract year n exceeds 96% and less than or equal to 99.75%;

$$\text{Monthly Transmission Charges MTC}(m) = T_{mn} * (AA / 96\%)$$

- c. If Actual Transmission System Availability for the month m of contract year n is greater than 99.75%;

$$\text{Monthly Transmission Charges MTC}(m) = T_{mn} * (99.75\% / 96\%)$$

- d. If Actual Transmission System Availability for the month m of contract year n is less than 95% and greater than or equal to 92.00%;

$$\text{Monthly Transmission Charges MTC}(m) = T_{mn} * (AA / 95\%)$$

- e. If Actual Transmission System Availability for the month m of contract year falls below 92%;

$$\text{Monthly Transmission Charges MTC}(m) = T_{mn} * (AA / 95\%) - 0.02 * (T_{mn} * (AA / 92\%))$$

where:

- AA is the actual Availability, as certified by RPC, as per procedure provided in Schedule 6.
- m is the month in Contract Year 'n'
- T_{mn} = Transmission Charges for the month 'm' in Contract Year 'n' = (Transmission Charge / no. of days in the Year n) * no. of days in month m

Transmission Service Agreement

Provided, no Transmission Charges shall be paid during the period for which the RLDC has not allowed the operation of the Element/Project due to the failure of the TSP to operate it as per the provisions of the Grid Code.

1.3 RLDC Fee & Charges

The payment of RLDC fee & charges, in accordance with relevant regulations of CERC, shall be the responsibility of the TSP.

Schedule: 5

Quoted Transmission Charges

[Quoted Transmission Charges from Annexure - 21 of the RFP of the Selected Bidder to be inserted here]

[To be incorporated from the Bid of the Selected Bidder submitted during the e-reverse auction after its selection]

Quoted Transmission Charges: Rs. Million

Proportionate Transmission Charges payable for each Element of the Project:

Sl. No.	Name of the Transmission Element	Percentage of Quoted Transmission Charges recoverable on Scheduled COD of the Element of the Project
1.	Establishment of 2500 MW, \pm 500 kV KPS3 (HVDC) [VSC] terminal station (2x1250 MW) at a suitable location near KPS3 substation with associated interconnections with 400 kV HVAC Switchyard*	100%
2.	Establishment of 2500 MW, \pm 500 kV South Olpad (HVDC) [VSC] terminal station (2x1250 MW) along with associated interconnections with 400 kV HVAC Switchyard of South Olpad S/s*	
3.	Establishment of KPS3 (HVDC) S/s along with 2x125 MVAR, 420 kV bus reactors along with associated interconnections with HVDC Switchyard*. The 400 kV bus shall be established in 2 sections through 1 set of 400 kV bus sectionaliser to be kept normally OPEN. 400/33 kV, 2x50 MVA transformers for exclusively supplying auxiliary power to HVDC terminal.	
4.	KPS3 – KPS3 (HVDC) 400 kV 2xD/C (Quad ACSR/AAAC/AL59 moose equivalent) line along with the line bays at both substations	
5.	\pm 500 kV HVDC Bipole line between KPS3 (HVDC) and South Olpad (HVDC) (with Dedicated Metallic Return) (capable to evacuate 2500 MW)	

Note: * The 400 kV interconnections (along with all associated equipment/ bus extension, etc.) between HVDC and HVAC switchyards shall be implemented by the TSP

Schedule: 6

Appendix –IV to Central Electricity Regulatory Commission

(Terms and Conditions of Tariff) Regulations, 2024

Procedure for Calculation of Transmission System Availability Factor for a Month

1. Transmission system availability factor for nth calendar month (“TAFPn”) shall be calculated by the respective transmission licensee, verified by the concerned Regional Load Dispatch Centre (RLDC) and certified by the Member-Secretary, Regional Power Committee of the region concerned, separately for each AC and HVDC transmission system and grouped according to sharing of transmission charges. In the case of the AC system, transmission System Availability shall be calculated separately for each Regional Transmission System and inter-regional transmission system. In the case of the HVDC system, transmission System Availability shall be calculated on a consolidated basis for all inter-state HVDC systems.

2. Transmission system availability factor for nth calendar month (“TAFPn”) shall be calculated by considering the following:
 - i) **AC transmission lines:** Each circuit of AC transmission line shall be considered as one element;
 - ii) **Inter-Connecting Transformers (ICTs):** Each ICT bank (three single- phase transformers together) shall form one element;
 - iii) **Static VAR Compensator (SVC):** SVC, along with SVC transformer, shall form one element;
 - iv) **Bus Reactors or Switchable line reactors:** Each Bus Reactors or Switchable line reactors shall be considered as one element;
 - v) **HVDC Bi-pole links:** Each pole of the HVDC link, along with associated equipment at both ends, shall be considered as one element;
 - vi) **HVDC back-to-back station:** Each block of the HVDC back-to-back station shall be considered as one element. If the associated AC line (necessary for the transfer of inter-regional power through the HVDC back-to-back station) is not available, the HVDC back-to-back station block shall also be considered unavailable;
 - vii) **Static Synchronous Compensation (“STATCOM”):** Each STATCOM shall be considered as a separate element.

3. The Availability of the AC and HVDC portion of the Transmission system shall be calculated

..... [Insert Name of the SPV]

232

| _____ 2024

by considering each category of transmission elements as under:

TAFPn (in %) for AC system:

$$= \frac{(o \times AV_o) + (p \times AV_p) + (q \times AV_q) + (r \times AV_r) + (u \times AV_u)}{(o + p + q + r + u)} \times 100$$

Where,

- o** = Total number of AC lines.
- AV_o** = Availability of o number of AC lines
- p** = Total number of bus reactors/switchable line reactors
- AV_p** = Availability of p number of bus reactors/switchable line reactors
- q** = Total number of ICTs
- AV_q** = Availability of q number of ICTs
- r** = Total number of SVCs
- AV_r** = Availability of r number of SVCs
- u** = Total number of STATCOM
- AV_u** = Availability of u number of STATCOM

TAFMn (in %) for HVDC System:

$$= \frac{\sum_{x=1}^s C_{xbp}(\text{act}) \times AV_{xbp} + \sum_{y=1}^t C_{ybtb}(\text{act}) \times AV_{ybtb}}{\sum_{x=1}^s C_{xbp} + \sum_{y=1}^t C_{ybtb}} \times 100$$

4. The availability for each category of transmission elements shall be calculated based on

$$\sum_{x=1}^s C_{xbp} + \sum_{y=1}^t C_{ybtb}$$

Where

- C_{xbp}(act)** = Total actual operated capacity of xth HVDC pole
- C_{xbp}** = Total rated capacity of xth HVDC pole
- AV_{xbp}** = Availability of xth HVDC pole
- C_{ybtb}(act)** = Total actual operated capacity of yth HVDC back-to-back station block
- C_{ybtb}** = Total rated capacity of yth HVDC back-to-back station block
- AV_{ybtb}** = Availability of yth HVDC back-to-back station block
- s** = Total no of HVDC poles
- t** = Total no of HVDC Back to Back blocks

Transmission Service Agreement

the weightage factor, total hours under consideration and non-available hours for each element of that category. The formulae for calculation of the Availability of each category of the transmission elements are as per **Appendix-V**. The weightage factor for each category of transmission elements shall be considered as under:

- (a) For each circuit of the AC line – The number of sub-conductors in the line multiplied by ckt-km;
 - (b) For each HVDC pole- The rated MW capacity x ckt-km;
 - (c) For each ICT bank – The rated MVA capacity;
 - (d) For SVC- The rated MVAR capacity (inductive and capacitive);
 - (e) For Bus Reactor/switchable line reactors – The rated MVAR capacity;
 - (f) For HVDC back-to-back stations connecting two Regional grids- Rated MW capacity of each block; and
 - (g) For STATCOM – Total rated MVAR Capacity.
5. The transmission elements under outage due to the following reasons shall be deemed to be available:
- i. Shut down availed for maintenance of another transmission scheme or construction of new element or renovation/upgradation/additional capitalization in an existing system approved by the Commission. If the other transmission scheme belongs to the transmission licensee, the Member Secretary, RPC may restrict the deemed availability period to that considered reasonable by him for the work involved. In case of a dispute regarding deemed availability, the matter may be referred to the Chairperson, CEA, within 30 days.
 - ii. Switching off of a transmission line to restrict over-voltage and manual tripping of switched reactors as per the directions of the concerned RLDC.
 - iii. Shut down of a transmission line due to the Project(s) of NHAI, Railways and Border Road Organization, including for shifting or modification of such transmission line or any other infrastructure project approved by Ministry of Power. Member Secretary, RPC may restrict the deemed availability period to that considered reasonable by him for the work involved; Provided that apart from the deemed availability, any other costs involved in the process of such shutdown of transmission line shall not be borne by the DICs.

Transmission Service Agreement

Provided that such deemed availability shall be considered only for the period for which DICs are not affected by the shutdown of such transmission line.

6. For the following contingencies, the outage period of transmission elements, as certified by the Member Secretary, RPC, shall be excluded from the total time of the element under the period of consideration for the following contingencies:
 - i) Outage of elements due to force majeure events beyond the control of the transmission licensee. However, whether the same outage is due to force majeure (not design failure) will be verified by the Member Secretary, RPC. A reasonable restoration time for the element shall be considered by the Member Secretary, RPC, and any additional time taken by the transmission licensee for restoration of the element beyond the reasonable time shall be treated as outage time attributable to the transmission licensee. Member Secretary, RPC may consult the transmission licensee or any expert for estimation of reasonable restoration time. Circuits restored through ERS (Emergency Restoration System) shall be considered as available;
 - ii) Outage caused by grid incident/disturbance not attributable to the transmission licensee, e.g. faults in a substation or bays owned by another agency causing an outage of the transmission licensee's elements, and tripping of lines, ICTs, HVDC, etc., due to grid disturbance. However, if the element is not restored on receipt of direction from RLDC while normalizing the system following grid incident/disturbance within reasonable time, the element will be considered not available for the period of outage after issuance of RLDC's direction for restoration;
 - iii) The outage period which can be excluded for the purpose of sub-clause (i) and (ii) of this clause shall be declared as under:
 - a. Maximum up to one month by the Member Secretary, RPC;
 - b. Beyond one month and up to three months after the decision at RPC;
 - c. Beyond three months by the Commission for which the transmission license shall approach the Commission along with reasons and steps taken to mitigate the outage and restoration timeline.
7. Time frame for certification of transmission system availability: (1) The following schedule shall be followed for certification of availability by the Member Secretary of the concerned RPC:
 - Submission of outage data along with documentary proof (if any) and TAFPn calculation by Transmission Licensees to RLDC/ constituents
 - By the 5th of the following month;

- Review of the outage data by RLDC / constituents and forward the same to respective RPC – by 20th of the month;
- Issue of availability certificate by respective RPC – by the 3rd of the next month.

Appendix-V

FORMULAE FOR CALCULATION OF AVAILABILITY OF EACH CATEGORY OF TRANSMISSION ELEMENTS

For AC transmission system

$$AV_o(\text{Availability of } o \text{ no. of AC lines}) = \frac{\sum_{i=1}^o W_i(T_i - T_{NAi})/T_i}{\sum_{i=1}^o W_i}$$

$$AV_q(\text{Availability of } q \text{ no. of ICTs}) = \frac{\sum_{k=1}^q W_k(T_k - T_{NAk})/T_k}{\sum_{k=1}^q W_k}$$

$$AV_r(\text{Availability of } r \text{ no. of SVCs}) = \frac{\sum_{l=1}^r W_l(T_l - T_{NAL})/T_l}{\sum_{l=1}^r W_l}$$

$$AV_p(\text{Availability of } p \text{ no. of Switched Bus reactors}) = \frac{\sum_{m=1}^p W_m(T_m - T_{NA m})/T_m}{\sum_{m=1}^p W_m}$$

$$AV_u(\text{Availability of } u \text{ no. of STATCOMs}) = \frac{\sum_{n=1}^u W_n(T_n - T_{NAn})/T_n}{\sum_{n=1}^u W_n}$$

$$AV_{x_{bp}}(\text{Availability of an individual HVDC pole}) = \frac{(T_x - T_N)}{T_x}$$

$AV_{y_{btb}}$ (Availability of an individual HVDC

$$\text{Back-to-back Blocks}) = \frac{(T_y - T_{NAy})}{T_y}$$

For the HVDC transmission system

For the new HVDC commissioned but not completed twelve months;

For first 12 months: $[(AV_{xpb} \text{ or } AV_{ybtb}) \times 95\%/85\%]$, subject to a ceiling of 95%.

Where,

- o = Total number of AC lines;
- AV_o = Availability of o number of AC lines;
- p = Total number of bus reactors/switchable line reactors;
- AV_p = Availability of p number of bus reactors/switchable line reactors;
- q = Total number of ICTs;
- AV_q = Availability of q number of ICTs;
- r = Total number of SVCs;
- AV_r = Availability of r number of SVCs;
- U = Total number of STATCOM;
- AV_u = Availability of u number of STATCOMs;
- W_i = Weightage factor for i th transmission line;
- W_k = Weightage factor for k th ICT;
- W_l = Weightage factors for inductive & capacitive operation of l th SVC;
- W_m = Weightage factor for m th bus reactor;
- W_n = Weightage factor for n th STATCOM.
- $T_i, T_k, T_l,$
, $T_m, T_n, T_x,$
 T_y = The total hours of i th AC line, k th ICT, l th SVC, m th Switched Bus Reactor & n th STATCOM, x th HVDC pole, y th HVDC back-to-back blocks during the period under consideration (excluding time period for outages not attributed to transmission licensee for the reasons given in Para 5 of the procedure)
- T_{NAi}, T_{NAk} = The non-availability hours (excluding the time period for outages not T_{NAi}, T_{NAm} , attributable to transmission licensee taken as deemed availability as $T_{NAi}, T_{NAk}, T_{NAx}, T_{NAy}$ per Para 5 of the procedure) for i th AC line, k th ICT, l th SVC, m th Switched Bus Reactor, n th STATCOM, x th HVDC pole and y th HVDC back-to-back block.

Transmission Service Agreement

Schedule: 7

Entire Bid (both financial bid and technical bid) of the Selected Bidder to be attached here

..... [Insert Name of the SPV]

Schedule: 8

Contract Performance Guarantee

(To be on non-judicial stamp paper of appropriate value as per Stamp Act relevant to place of execution. Foreign entities submitting Bids are required to follow the applicable law in their country.)

In consideration of the [Insert name of the SPV or Selected Bidder on behalf of the TSP, or Lead Member in case of the Consortium, with address] agreeing to undertake the obligations under the Transmission Service Agreement datedand the other RFP Project Documents and the Nodal Agency and the PFC Consulting Limited, agreeing to execute the *RFP Project Documents* with the Selected Bidder, regarding setting up the Project, the [Insert name and address of the bank issuing the guarantee and address of the head office] (hereinafter referred to as “Guarantor Bank”) hereby agrees unequivocally, irrevocably and unconditionally to pay to (being the Nodal Agency) _at[Insert the Place from the address of the Nodal Agency indicated in the TSA] forthwith on demand in writing from the Nodal Agency or any Officer authorized by it in this behalf, any amount up to and not exceeding Rupees Crores (Rs.) only [Insert the amount of the bank guarantee] on behalf of M/s. [Insert name of the Selected Bidder or SPV].

This guarantee shall be valid and binding on the Guarantor Bank up to and includingand shall not be terminable by notice or any change in the constitution of the Bank or the term of the Transmission Service Agreement or by any other reasons whatsoever and our liability hereunder shall not be impaired or discharged by any extension of time or variations or alternations made, given, or agreed with or without our knowledge or consent, by or between parties to the respective agreement.

Our liability under this Guarantee is restricted to Rs. Crores (Rs.) only. Our Guarantee shall remain in force until [Insert the date of validity of the Guarantee as per Article 0 of this Agreement]. The Nodal Agency, shall be entitled to invoke this Guarantee up to three hundred sixty five (365) days of the last date of the validity of this Guarantee.

The Guarantor Bank hereby expressly agrees that it shall not require any proof in addition to the written demand from (in its roles as the Nodal Agency), made in any format, raised at the above mentioned address of the Guarantor Bank, in order to make the said payment to Nodal Agency.

The Guarantor Bank shall make payment hereunder on first demand without restriction or conditions and notwithstanding any objection by [Insert name of the Selected Bidder], [Insert name of the TSP] and /

..... [Insert Name of the SPV]

or any other person. The Guarantor Bank shall not require Nodal Agency to justify the invocation of this BANK GUARANTEE, nor shall the Guarantor Bank have any recourse against Nodal Agency in respect of any payment made hereunder.

THIS BANK GUARANTEE shall be interpreted in accordance with the laws of India.

The Guarantor Bank represents that this BANK GUARANTEE has been established in such form and with such content that it is fully enforceable in accordance with its terms as against the Guarantor Bank in the manner provided herein.

THIS BANK GUARANTEE shall not be affected in any manner by reason of merger, amalgamation, restructuring, liquidation, winding up, dissolution or any other change in the constitution of the Guarantor Bank.

THIS BANK GUARANTEE shall be a primary obligation of the Guarantor Bank and accordingly Nodal Agency shall not be obliged before enforcing this BANK GUARANTEE to take any action in any court or arbitral proceedings against), KPS III HVDC TRANSMISSION LIMITED or the Selected Bidder, as the case may be, to make any claim against or any demand on), KPS III HVDC TRANSMISSION LIMITED or the Selected Bidder, as the case may be, or to give any notice to), KPS III HVDC TRANSMISSION LIMITED or the Selected Bidder, as the case may be, or to enforce any security held by the Nodal Agency or to exercise, levy or enforce any distress, diligence or other process against), KPS III HVDC TRANSMISSION LIMITED or the Selected Bidder, as the case may be.

The Guarantor Bank acknowledges that this BANK GUARANTEE is not personal to Nodal Agency and may be assigned, in whole or in part, (whether absolutely or by way of security) by Nodal Agency to any entity to whom the Nodal Agency is entitled to assign its rights and obligations under the Transmission Service Agreement.

The Guarantor Bank hereby agrees and acknowledges that Nodal Agency shall have a right to invoke this Bank Guarantee either in part or in full, as it may deem fit.

Notwithstanding anything contained hereinabove, our liability under this Guarantee is restricted to Rs. Crores (Rs.) only and it shall remain in force until[Date to be inserted on the basis of Article 0of the Transmission Service Agreement], with an additional claim period of three hundred sixty five (365) days thereafter. This BANK GUARANTEE shall be extended from time to time for such period, as may be desired by [Insert name of the Selected Bidder or Lead Member in case of the Consortium or SPV]. We are liable to pay the guaranteed amount or any part thereof under this Bank Guarantee only if Nodal Agency serves upon us a written claim or demand.

Transmission Service Agreement

In witness where of:

Signature

Name:

Power of attorney No.:

For:

..... [Insert Name of the Bank]

Banker's Seal and Full Address, including mailing address of the Head Office

..... [Insert Name of the SPV]

241

| _____ 2024

Schedule: 9

Methodology for determining the Relief Under Force Majeure Event & Change in Law during Construction Period

The relief in the form of revision in tariff due to Force Majeure Event leading to extension of Scheduled COD for a period beyond one hundred eighty (180) days and/ or Change in Law during the construction period shall be as under:

$$\Delta T = [(P \times d)] \div [1 - (1 + d)^{-n}]$$

Where,

ΔT = Change in Transmission Charges for each year

P = Sum of cumulative increase or decrease in the cost of the Project due to Change in Law and interest cost during construction corresponding to the period exceeding one hundred eighty (180) due to Force Majeure Event leading to extension of Scheduled COD for a period beyond one hundred eighty (180) days

n = number of years over which the Transmission Charges has to be paid

d = Discount rate as notified by the CERC, applicable on the Bid Deadline

The increase in Transmission Charges as stated above shall be applicable only if the value of increase in Transmission Charges as calculated above exceeds 0.30% (zero point three percent) of the quoted Transmission Charges of the TSP.